

# VL1100 AS / AI

automated ellipsoidal  
reflector spotlight



The VARI\***LITE** VL1100 ERS luminaire, borne from the very popular VL1000 ERS luminaire, combines the functionality of one of the most popular conventional lighting tools — the ellipsoidal reflector spotlight — with the versatility of an automated luminaire. All VL1100 models have undergone design enhancements to provide more quiet and fluid operation.

Automated functions include CYM color mixing, rotating gobos (gobos/patterns sold separately), variable diffusion and a zoom lens that ranges from 19° to 36° for normal imaging and a super zoom function that ranges to 70°. A new 50 kHz. drive system quiets all two-phase motors both when moving and static. A central bearing system in the gobo wheel reduces noise and ensures smooth operation of the mechanism. Additionally, new, three-phase, ultra quiet stepper motors provide for smoother and quieter pan and tilt operation.

Models VL1100AI and VL1100AS deliver more than 15,000 lumens with the higher color temperature of the 575 watt arc source. These models also include a mechanical dimmer and a truss-mounted, fanless ballast.

The VL1100AS model includes an automated, four-blade shutter mechanism that provides control of all shutter functions popular in conventional ellipsoidal reflector spotlights. The VL1100AI model includes a beam size iris.

## Arc Units

### Programmable Functions

<b>Zoom Optics:</b>	Continuously variable field angle in imaging range from 19° to 36°, super zoom angles to 70° is programmable over a timed range of 2 seconds to 20 minutes.
<b>Color Mixing System:</b>	A fully cross-fading CYM color system. All motors utilize a noise reducing, 50kHz. drive system that quiets operation during movement and also while static.
<b>Diffusion:</b>	Field or gobo can be continuously and smoothly diffused to wash.
<b>Dimmer:</b>	A coated glass dimmer wheel provides full-field dimming designed for smooth timed fades.
<b>Rotating Gobo Wheel:</b>	Six position rotating gobo wheel with a central bearing system, five rotatable and indexable gobo positions plus open. (Patterns are not included with the fixture.)
<b>Shutter (Framing Models):</b>	Four-blade system can frame and crop beam field and gobos. Each individual shutter is capable of translating to beam center while also rotating ±35°. Entire shutter rotates ±45°.
<b>Beam Size Control (Iris Models):</b>	In addition to the zoom optics, a mechanical iris provides continuous beam size control for both rapid changes and smooth timed beam angle changes.
<b>Pan and Tilt:</b>	Smooth, timed continuous motion using three phase, ultra quiet stepper motors with encoder correction. Pan range is 540°; tilt is 270°. Resolution is 0.1°. Unit will calibrate to support close hangs (yoke-to-yoke).

## Description

<b>Source:</b>	575 W Arc Lamp, Phillips MSR 575HR (or equivalent) Color Temp: 6000K CRI: 95 Output: >15,000 Lumens Rated Life: 1,000 Hours
<b>Optional Source:</b>	575 W Arc Lamp, Phillips MSD 575HR (or equivalent) Color Temp: 5900K CRI: 75 Output: >14,000 Lumens Rated Life: 2,000 Hours
<b>Power Requirements:</b>	3 to 9 Amps depending upon input voltage. 90 -264 VAC 50/60 Hz.
<b>Reflector:</b>	Precision glass reflector with dichroic cold mirror coating.
<b>Operational Temperature:</b>	-20° to 122°F (-29° to 50°C)
<b>Cooling:</b>	Free convection cooling when hung. Floor mounted units and extreme ambient temperatures activate a low-noise, forced-air cooling system.
<b>Control:</b>	Completely compatible with a wide variety of DMX512 lighting control consoles.
<b>Mounting Position:</b>	VL1100 ERS luminaires can be mounted and operated in any orientation.
<b>Spacing:</b>	Full range of motion on 26.5" centers. Hangs as close as 20.0".
<b>Weight:</b>	Luminaire: 70.0 lbs (32.0 kg) / Ballast: 16.6 lbs (7.52 kg).

## Ordering Information

<b>Luminaires:</b>	
20.9664.0001.12	VL1100AS ERS, Arc, Framing Shutters, Includes 575W Arc Lamp
20.9664.0001.12.02	VL1100AS ERS, Arc, WHITE, Framing Shutters, Includes 575W Arc Lamp
20.9664.0001.13	VL1100AI ERS, Arc, Iris, Includes 575W Arc Lamp
20.9664.0001.13.02	VL1100AI ERS, Arc, WHITE, Iris, Includes 575W Arc Lamp

<b>Accessories:</b>	
71.2528.0575	575 Watt Arc Lamp, MSR575HR
71.2556.0575	575 Watt Long-Life Arc Lamp, MSD575HR
22.9620.0194	Safety Cable
28.8500.0054	USB Luminaire Programming Kit
55.6840.0001	Truss Hook, Mega-Clamp, Round and Square
55.6841.0001	Truss Hook, Mega-Claw for 2" Round Tube
41.6010.XXXX	Gobo, Series 1000 (Specify pattern from catalog to complete P/N.)



**PHILIPS**  
**VARI\***LITE****

# VL1100 AS / AI

automated ellipsoidal reflector spotlight

## Arc Units

### Arc Ballast Unit Description:

#### Input

Voltage Range: 90 to 275V, Auto Ranging  
 Frequency: 50 or 60 Hz  
 Current Range: 2.7 to 9.0A\*  
 Power Factor: ± 0.97

#### Weight & Dimensions

Mounting Position: Ballast can be mounted in any orientation.  
 Weight: 16.6 lbs (7.52 kg)

#### Output

Open Circuit Voltage: ± 450V  
 Lamp Voltage: 100V\*  
 Lamp Current: 6.25A\*  
 Lamp Power: 625W\*  
 Output Current Shape: Square wave  
 Output Frequency: 200Hz\*  
 High Frequency Ripple Current: ± 3%

\* Nominal Values

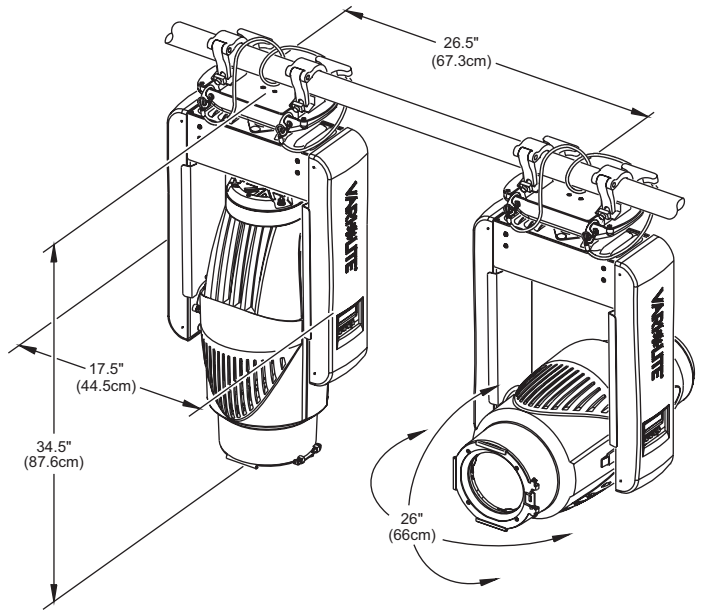
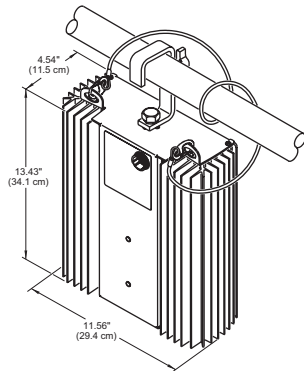

Shown with accessories that are sold separately.

### Specifications

The unit shall be an integrally designed, remote-controlled, automated ellipsoidal reflector spot luminaire. An integral enclosure/pan tube supports the luminaire with provisions for two hooks. The pan tube serves as an interconnection point for power and data. Low noise fans provide forced-air cooling for internal components during extreme operating conditions. The rear cap provides three-point lamp adjustment and easy access to the lamp for replacement.

An AC input connector, a remote ballast interconnect cable and two, five-pin DMX512 compatible connectors (in and through) are provided. The unit can be controlled by a wide variety of DMX512 consoles.

Each unit shall be equipped with a high-speed processor providing diagnostic and self-calibration functions as well as internal test routines and software update capabilities. A yoke arm mounted panel and display provide the user interface.

The unit shall contain three-phase stepper motors to provide movement of the head through 540° in the horizontal plane (pan) and 270° in the vertical plane (tilt). The luminaire calibrates to minimize hanging distances.

A zooming multi-element optical system provides continuous focus of gobo images for field angles from 19° to 36°. A super zoom function provides field angles to 70°. Independent control of edge is provided.

A CYM color mixing system shall be provided for a broad range of user color selection. A variable diffusion stage shall be included. This stage provides controlled reduction of the contrast ratio of imagery and beam edges. The effect is a continuous transition from spotlight to floodlight.

A six-position gobo wheel with five rotatable, indexable gobo positions and one open position shall be included. A central bearing system in the gobo wheel shall reduce noise and ensure smooth operation of the mechanism. Gobos are easily installed and removed. (A wide selection of gobos are available from Vari-Lite.)

Framing shutter models contain four shutter blades that translate radially across the beam. Each individual shutter is capable of translating to beam center while also rotating ±35°. The framing shutter mechanism rotates as a unit ±45°.

Iris models contain a beam size iris suitable for producing narrow beams and cropping gobos.

A 50 kHz. drive system shall quiet all two phase motors in the luminaire both when moving and static.

The unit is ETL and ETLc certified and CE marked. The unit's exterior finish shall be available in black or white. Custom colors may be special ordered.

### Photometric Data\*

FIELD ANGLE (Degrees)	FIELD DIAMETER TN'	BEAM ANGLE (Degrees)	BEAM DIAMETER TN'	CANDELA (cd)
<b>VL1100 ERS - 575W Metal Halide</b>				
19.0	.335	13.0	.228	235,300
27.0	.480	18.0	.317	123,700
36.5	.660	24.0	.425	66,500
70.0 (Super Zoom)	1.40	28.5	.508	31,600
<b>VL1100 ERS - 575W Metal Halide (Long Life)</b>				
19.5	.344	13.5	.237	205,400
27.0	.480	18.5	.326	104,900
36.0	.650	24.5	.434	56,400
70.0 (Super Zoom)	1.40	28.0	.499	27,000

Notes:

\* All data taken with seasoned light source at 20 hours of life.

<sup>1</sup> Multiply distance by Tn to determine coverage.

To calculate center beam Illuminance (I), at a specific distance (D):  $I = cd \div D^2$

— if (D) is in feet, (I) is in foot candles

— if (D) is in meters, (I) is in lux



©2010 Philips Group. All rights reserved. Printed in the U.S.A. We reserve the right to change details of design, materials and finishes. Specifications are subject to change without notice. VARI\*LITE automated lighting equipment is made in the U.S.A.



Vari-Lite  
 10911 Petal Street  
 Dallas, TX 75238  
 1.877.VARILITE  
 fax: 214.647.8038  
 www.vari-lite.com



VL1100AS/AI\_071610