

VL3000™ Spot

l u m i n a i r e



The VARI*LITE® VL3000™ Spot luminaire sets new standards for imagery, beam control, color and brightness in spot luminaires.

The VARI*LITE® VL3000™ Spot luminaire features 6:1 zoom optics, CYM color mixing, variable CTO color temperature correction, a six-position color wheel, three gobo/effects wheels, a beam size iris and separate dimmer and ultra-fast strobe mechanisms. A standard pallet of gobos, effects and colors is provided with the unit. Custom gobos, effects and colors are available.

An upper enclosure houses the control electronics as well as the arc power supply for the 1200 watt short arc lamp. The arc power supply is power factor corrected for efficient power distribution.

The VL3000™ Spot luminaire can be controlled from a wide variety of DMX-512 consoles.

The luminaire is the same size as the VL3000™ Wash luminaire, providing a consistent hang configuration and appearance no matter which luminaire type is required.

Programmable Functions

Color System:	A three-filter CYM cross-fading mechanism. A fixed color wheel with six interchangeable color filters and continuous wheel rotation for additional effects. It includes a variable CTO color temperature correction filter.
Zoom Optics:	A 13-element 6:1 zoom optics system, covering a range from 10° to 60°.
Beam Size Control:	A mechanical iris provides continuous beam size control for rapid and smooth timed beam angle changes.
Intensity Control:	Full field dimming designed for smooth timed fades as well as quick dimming effects.
Strobe:	High-performance dual blade strobe system capable of ultra-fast operation.
Rotating Gobo Wheels:	Three gobo/effects wheels combine to provide 14 rotatable, indexable gobo positions. Each wheel also has one open position.
Edge and Pattern Focus:	Variable beam focus to soften edges of gobos or spots. Remarkable depth of field capability allows morphing effects between all pattern and effects wheels.
Pan and Tilt:	Smooth, time-controlled continuous motion by way of three-phase stepper motor systems.
Range:	Pan - 540°, Tilt - 270°.
Accuracy:	0.3° resolution.

Description

Source:	1200W Short Arc Lamp	Color Temperature	6000°K
		CRI	85
Fixture Output:	20,000 lumens.		
Power Requirements:	Standard AC power distribution from 200–264 VAC, 50/60 HZ. The unit requires 7 to 12 A depending on the AC supply voltage.		
Reflector:	Precision glass reflector system with dichroic cold mirror coating.		
Operational Temperature:	-20° to 122°F (-29° to 50°C).		
Cooling:	Forced air cooling.		
Control:	Completely compatible with a wide variety of DMX-512 consoles.		
DMX Channels:	28		
Mounting Position:	The VL3000™ Spot luminaire can be mounted and operated in any orientation.		
Spacing:	Hangs on 26 in. (66 cm) centers.		
Weight:	91 lbs (41 kg).		

Accessories

22.9620.0194	Safety Cable Assembly
55.6840.0001	Truss Hook, Mega-Clamp (Round and Square)
55.6841.0001	Truss Hook, Mega-Claw (for 2" Round Tube)
71.9678.0012	1200W Short Arc Lamp

PART #: 20.9678.0001



VARI*LITE®
Express yourself.

Vari-Lite is a Philips group brand

PHILIPS

VL3000™ Spot

l u m i n a i r e

Specifications

The unit is an integrally designed, remote-controlled, motorized spot luminaire. The head, yoke and enclosure housings are constructed of aluminum alloy for light weight, strength and durability. Low-noise fans provide forced-air cooling for internal components. The rear cap is hinged, providing easy access to the lamp for replacement.

A single AC input cable along with two, five-pin DMX-512 compatible connectors (in and through) are provided. The unit can be controlled from a wide variety of DMX-512 consoles.

Each unit is equipped with an on-board processor providing diagnostic and self-calibration functions as well as internal test routines and software update capabilities.

The unit contains two independent three-phase stepper motors to provide movement of the head through 540° in the horizontal plane (pan) and 270° in the vertical plane (tilt). The pan and tilt mechanisms are belt-driven, providing positional resolution and repeatability of 0.3° on either axis.

A 6:1 zoom optics system adjusts the projected field angle over a range of 10° to 60°. Variable beam focus is provided to soften the edges of gobos or spots and to provide gobo morphing. The projected image remains in focus throughout the entire zoom range.

The unit contains a CYM color mixing system, as well as variable CTO color temperature correction.

One continuously spinning, removable color filter wheel is included. The color wheel holds six interchangeable dichroic colors to allow for custom configurations. The unit comes equipped with a standard palette of dichroic color filters. (Custom colors are available from Vari-Lite.)

Three gobo/effects wheels – two six-position, one five-position – each containing individually rotating, indexable gobos and patterned glass effects. The rotating gobos are easily interchangeable to allow customization of the unit. The unit comes equipped with a standard set of gobos and effects. (A wide selection of colored and patterned gobos and effects is available from Vari-lite.)

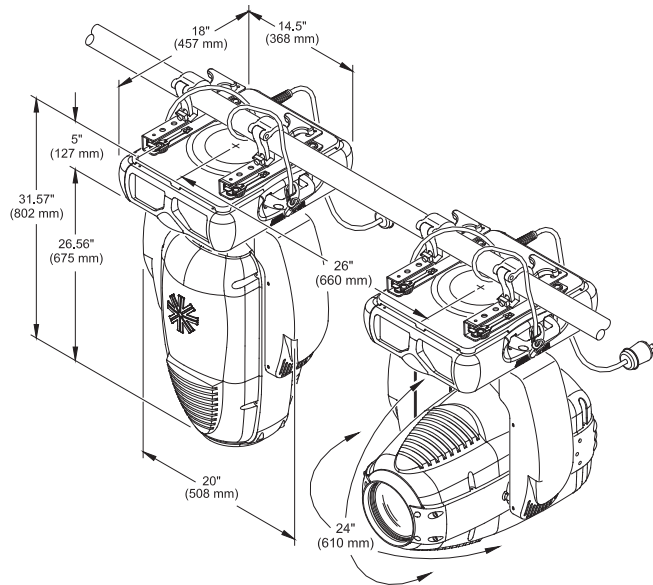

A mechanical iris provides continuous beam size control for rapid and smooth timed beam angle changes.

The unit contains a patterned glass dimmer wheel that provides full field dimming and allows for smooth timed fades and fast blackouts.

A dual blade strobe and dousing system provides variable strobe effects capable of rapid operation.

The unit shall be ETL and ETLc certified and CE-marked. Exterior finish is black.

Photometric Data*

VL3000 Spot Luminaire – 1200W Metal Halide					
Zoom Lens Position	Candela* (cd)	Beam Angle	Beam Diameter TN ¹	Field Angle (degrees)	Field Diameter TN ¹
NFOV	1,201,000	9.0	0.157	10.0°	0.175
MFOV	104,400	31.0	0.555	35.0°	0.631
WFOV	40,930	46.0	0.849	56.0°	1.063



¹ Multiply distance by Tn to determine coverage.

To calculate center beam illuminance (I), at a specific distance (D): $I = \frac{cd}{D^2}$
 — if (D) is in feet, (I) is in foot candles
 — if (D) is in meters, (I) is in lux

* Note:

All data taken with seasoned light source at 20 hours of life.
 Fixture output = 20,000 lumens.

VARI*LITE
 Express yourself.

©2008 Philips Group. All rights reserved. Printed in the U.S.A. **VARI*LITE** is a trademark owned by Philips Group and is registered in the United States and other countries. VL3000™ and the Vari-Lite Asterisk are also trademarks owned by Philips Group. Certain products listed in this document may be protected by applicable patents and patents pending. Philips will aggressively defend all of its intellectual property. We reserve the right to change details of design, materials and finishes. Specifications are subject to change without notice. **VARI*LITE** automated lighting equipment is made in the U.S.A.



Vari-Lite

10911 Petal Street

Dallas, TX 75238

1.877.VARILITE

fax: 214.647.8038

www.vari-lite.com