

# VL3500™ Wash

l u m i n a i r e



The VL3500™ Wash luminaire is the high intensity wash tool in the VARI\***LITE**® Series 3000™ family of luminaires. With an output that exceeds 50,000 lumens, as well as varied new options for color and beam control, this fixture will soon be the standard by which all wash lights are measured.

The VL3500™ Wash luminaire features internal zoomable beam optics with either Fresnel or Buxom options, an interchangeable front lens system, and a five-position aperture wheel. The fixture provides CYM color mixing, variable CTO color temperature correction, dual five-position color wheels, a separate dimmer, and an independent dual blade strobe mechanism.

In conjunction with its zoomable optics system, Vari-Lite introduces the VARI\***BRITE**™ mode. From virtually any zoom position, this mode can be engaged to offer a tight column of remarkably intense light making the VL3500™ the most versatile wash luminaire on the market.

The VL3500™ Wash allows users to operate its single lamp at two different wattages via either a control channel setting or a lamp menu option. With only a setting adjustment, the fixture will run its short arc lamp at either 1200W or 1500W without any detrimental effects on the lamp.

An upper enclosure houses the control electronics as well as an arc power supply for the unit's short arc lamp. The arc power supply is power factor corrected for efficient power distribution and reliability.

The VL3500™ Wash is similar in size to our other Series 3000™ luminaires, which provides a consistent hang configuration and appearance no matter which luminaire type is utilized.

## Programmable Functions

### Color System:

Six color control wheels total. A three filter CYM cross fading system, two fixed color wheels with five interchangeable color filters each capable of continuous wheel rotation for additional effects, and a variable CTO color temperature correction wheel.

### Beam Control:

A zoomable beam spreader mechanism provides continuous beam size control for rapid or smooth timed changes. The VARI\***BRITE**™ mode, accessible from all zoom positions, splits the beam spreader and produces a tight, intense column of light. Easily interchangeable glass panels (included) allow user to choose either Fresnel or Buxom spreader patterns.

Beam may also be controlled through the use of one of three easily interchangeable front lenses: Plano Convex-Clear, Plano Convex-Stipple, and Fresnel – all three included. All front lens assemblies have mounting points to allow for attachment of aftermarket accessory hardware.

Aperture wheel offering five different diameter openings (25mm, 30mm, 35mm, 40mm, 52mm) and capable of continuous rotation for effects purposes.

### Intensity Control:

Full field dimming designed for both smooth timed fades as well as quick dimming effects.

### Strobe:

High-performance dual blade strobe system independent of dimmer wheel and capable of ultra-fast operation.

### Pan and Tilt:

Smooth, time-controlled continuous motion by way of three-phase stepper motor systems.

### Range:

Pan - 540°, Tilt - 270°.

### Accuracy:

0.3° resolution.

## Description

### Source:

Dual wattage, double ended lamp. Capable of operation at 1200W or 1500W – mode selectable from fixture or console. (Also capable of operation in 900W “standby” mode.)

### Color Temperature:

6000K at 1500 watts and 6300K at 1200 watts.

### Fixture Output:

>50,000 lumens in 1500 watt mode.

### Power Requirements:

Standard AC power distribution from 200 – 264 VAC, 50/60 HZ. The unit requires 7 to 12 A depending on the AC supply voltage.

### Reflector:

Precision glass reflector system with dichroic cold mirror coating.

### Operational Temperature:

-20° to 104°F (-29° to 40°C)

### Cooling:

Stepped, forced-air cooling dependent upon operational wattage of lamp.

### Control:

Completely compatible with a wide variety of DMX-512 consoles.

### DMX Channels:

19

### Mounting Position:

The VL3500™ Wash luminaire can be mounted and operated in any orientation.

### Spacing:

Hangs on 28 inch (71.2 cm) centers.

### Weight:

Approximately 96 lbs. (43.5 kg)

## Accessories

22.9620.0194

Safety Cable Assembly

55.6840.0001

Truss Hook, Mega-Clamp (Round and Square)

55.6841.0001

Truss Hook, Mega-Claw (for 2" Round Tube)

21.9686.0618

Clear front lens

21.9686.0617

Stipple front lens

21.9686.0619

Fresnel front lens

**PHILIPS**  
**VARI\***LITE**®**

# VL3500™ Wash

l u m i n a i r e

## Specifications

The unit is an integrally designed, remote-controlled, motorized wash luminaire. The head, yoke and enclosure housings are constructed of aluminum alloy for light weight, strength and durability. Low-noise fans provide forced-air cooling for internal components. The rear cap is hinged, providing easy access to the lamp for replacement.

A single AC input cable along with two, five-pin DMX-512 compatible connectors (in and through) are provided. The unit can be controlled from a wide variety of DMX-512 consoles.

Each unit is equipped with an on-board processor providing diagnostic and self-calibration functions as well as internal test routines and software update capabilities.

The unit contains two independent three-phase stepper motors to provide movement of the head through 540° in the horizontal plane (pan) and 270° in the vertical plane (tilt). The pan and tilt mechanisms are belt-driven, providing positional resolution and repeatability of 0.3° on either axis.

A zoomable beam spreader mechanism provides continuous beam size control for rapid changes and smooth timed zoom changes. Users may install either of two sets of included interchangeable internal lenses that provide a zoom range of 2.7:1 with the fresnel internal lens and of 4:1 with the buxom internal lens.

Beam shall also be controlled with one of three interchangeable front lenses – which shall be provided as standard equipment. Each front lens comes with mounting points to allow attachment of aftermarket hardware – provided by others. Additional beam manipulation shall be achieved by an aperture wheel with five separate openings of different diameters and capable of continuous rotation.

The unit contains a CYM color mixing system, as well as variable CTO color temperature correction. Two color wheels capable of continuously spinning are also included. Each of the two wheels holds five interchangeable dichroic colors to allow for custom configurations. The unit comes equipped with a standard palette of dichroic color filters.

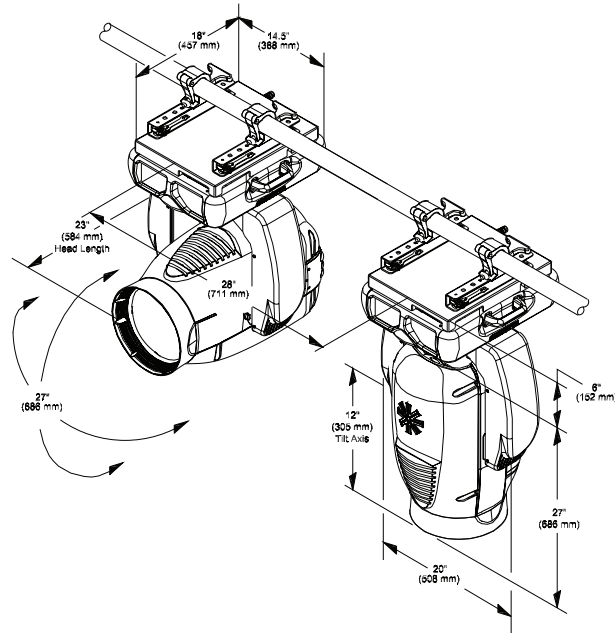

The unit contains a patterned glass dimmer wheel that provides full field dimming and allows for smooth timed fades and fast blackouts.

A dual blade strobe and dousing system provides variable strobe effects capable of rapid operation.

The unit shall be ETL and ETLc certified and CE-marked. Exterior finish is black.

**PHILIPS**  
**VARI\**LITE***

©2009 Philips Group. All rights reserved. Printed in the U.S.A. VARI\**LITE*® is a trademark owned by Philips Group and is registered in the United States and other countries. VL3000™, VL3500™ and VARI\**BRITE*™ and the Vari-Lite Asterisk are also trademarks owned by Philips Group. Certain products listed in this document may be protected by applicable patents and patents pending. Philips will aggressively defend all of its intellectual property. We reserve the right to change details of design, materials and finishes. Specifications are subject to change without notice. VARI\**LITE*® automated lighting equipment is made in the U.S.A.



Vari-Lite

10911 Petal Street

Dallas, TX 75238

1.877.VARILITE

fax: 214.647.8038

[www.vari-lite.com](http://www.vari-lite.com)

VL3500W\_0509