

INSTRUCTIONS FOR FITTING ALCORA / ELARA ANALOGUE OUTPUT KITS

WARNING

Unplug the power supply unit from the desk before removing any covers.

Servicing of equipment must be undertaken by appropriately qualified persons only.

The Company cannot accept responsibility for repairs or modifications that are not competently executed and in accordance with service or upgrade information.

Before attempting to fit the analogue output kit to your Alcora/Elara lighting desk please read these instructions carefully.

Electrostatic discharge (ESD) can damage the circuit boards and other components. The procedure described below should be carried out at an ESD safe workstation only. If such a station is not available, some ESD protection can be provided by wearing an antistatic wrist strap and attaching it to a metal part of the desk chassis.

This equipment is designed for professional stage lighting control, and is unsuitable for any other purpose. It should be used by, or under the supervision of, appropriately qualified or trained persons only.

Zero 88 Lighting Ltd. reserves the right to make changes to the equipment described in these instructions without prior notice.

E & OE. © Zero 88 Lighting Ltd. 2002.

Tel: +44 (0) 1633 838088 (24 Hour Answer Phone)

Fax: +44 (0) 1633 867880

E-Mail: sales@zero88.com

Web: www.vari-lite.com

KIT CONTENTS

00-118-00	00-119-00	00-120-00
Alcora/Elara 12 Mk1	Alcora/Elara 12 Mk2	Alcora/Elara 24 Mk2
1x Analogue Output PCB	1x Analogue Output PCB	2x Analogue Output PCBs
1x Back Panel	4x M4 Screws	8x M4 Screws
4x Spacers	1x Ribbon cable (2 plugs)	1x Ribbon cable (3 plugs)
	2x Ribbon cable clips	3x Ribbon cable clips

IMPORTANT - METALWORK VARIATIONS

It is important to confirm which revision of the Alcora/Elara metalwork you have.

Alcora/Elara 12 Mk1 (grey panel) Revision A **(kit 00-118-00 required)**

The back panel of the desk has a metal blank plate fitted. Refer to the fitting instructions on page 3.

Alcora/Elara 12 Mk1 (grey panel) Revision B **(kit 00-118-00 required)**

The back panel of the desk has five screws securing it to the base panel. There are no holes or markings for the analogue outputs. Refer to the fitting instructions on page 4.

Alcora/Elara 12 Mk1 (grey panel) Revision C **(kit 00-118-00 required)**

The back panel of the desk has five screws securing it to the base panel. There are markings for the analogue outputs, and 4 holes fitted with blanking plugs. Refer to the fitting instructions on page 5.

Alcora/Elara 12 Mk2 (blue/green panel) **(kit 00-119-00 required)**

There are markings for the analogue outputs, and 4 holes fitted with blanking plugs. Refer to the fitting instructions on page 6.

Alcora/Elara 24 Mk2 (blue/green panel) **(kit 00-120-00 required)**

There are markings for the analogue outputs, and 8 holes fitted with blanking plugs. Refer to the fitting instructions on page 7.

Instructions for Alcora/Elara 12 Mk1 (grey panel) Revision A

Discard the Back Panel from the kit, it cannot be used on this revision of the desk. Part number 90-052-00 is required, which is not supplied with the kit as standard

Ensure that the desk is switched off. Disconnect the power supply unit, DMX output cable, audio input, remote go/step and memory module, if connected. Turn the desk upside down and rest on suitable supports (e.g. foam rubber). **Do not rest the desk on the fader knobs as this may damage the faders.**

Remove the nuts and washers from the Audio Input and Remote Go/Step sockets on the back panel and remove the two screws holding the back panel to the sides (see fig 1). Lift the base panel up slightly and then pull it towards the handle so that it comes out of the groove in the underside of the desk.

Unplug the DMX Molex connector from the main PCB, and then remove the base panel completely. Remove the blank plate from the back panel by removing the two screws. Retain the screws.

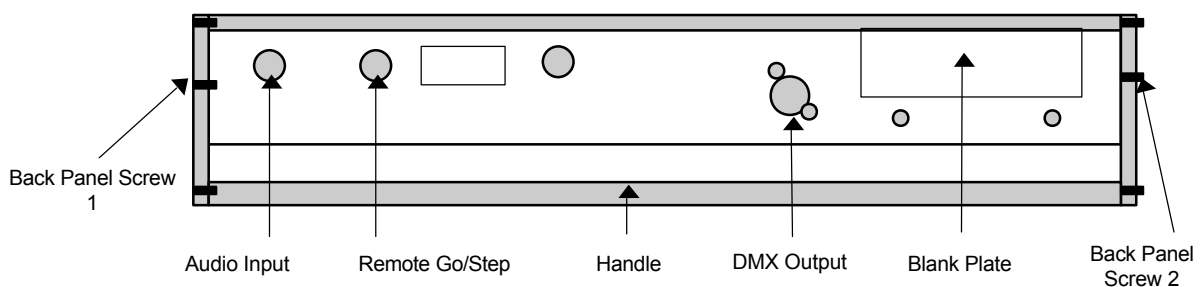

Fig 1 - Back Panel (not inverted)

Remove the 4 screws from the main PCB and replace with the 4 metal spacers provided (see fig 2). Retain the screws. Position the analogue PCB above the main PCB and ensure that the pins on the analogue PCB are correctly inserted into the holes in the main PCB (fig 2). Secure the analogue PCB to the spacers using the 4 screws originally removed from the main PCB.

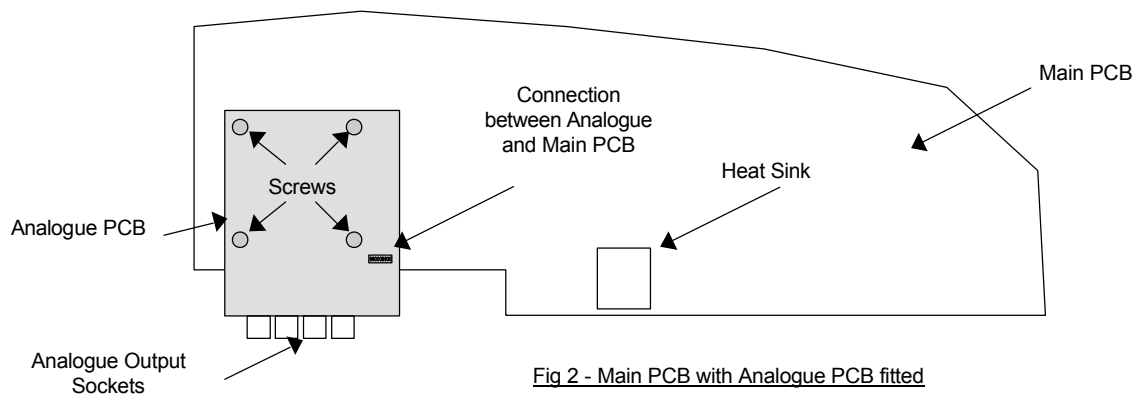

Fig 2 - Main PCB with Analogue PCB fitted

Place the analogue option plate (part no. 90-052-00) over the 4 analogue output sockets on the analogue PCB, lifting slightly to ensure that the plate is located in the groove. Position the base panel over the main PCB and reconnect the DMX Molex connector.

Refit the base panel to the desk, being careful not to trap the wires from the DMX socket. Secure the analogue option plate to the back panel using the two screws. Secure the back panel to the sides using the two screws. Refit the washers and nuts on the Audio Input and Remote Go/Step sockets on the back panel.

Instructions for Alcora/Elara 12 Mk1 (grey panel) Revision B

Ensure that the desk is switched off. Disconnect the power supply unit, DMX output cable, audio input, remote go/step and memory module, if connected. Turn the desk upside down and rest on suitable supports (e.g. foam rubber). **Do not rest the desk on the fader knobs as this may damage the faders.**

Remove the nuts and washers from the Audio Input and Remote Go/Step sockets on the back panel and remove the two screws holding the back panel to the sides (see fig 3). Remove the five screws holding the back panel to the base panel (fig 3).

Lift the base panel up slightly and then pull it towards the handle so that it comes out of the groove in the underside of the desk. Remove the base panel completely.

Disconnect the DMX output socket from the back panel by removing the two screws (fig 3). Remove the back panel by lifting it slightly and pulling it towards the handle.

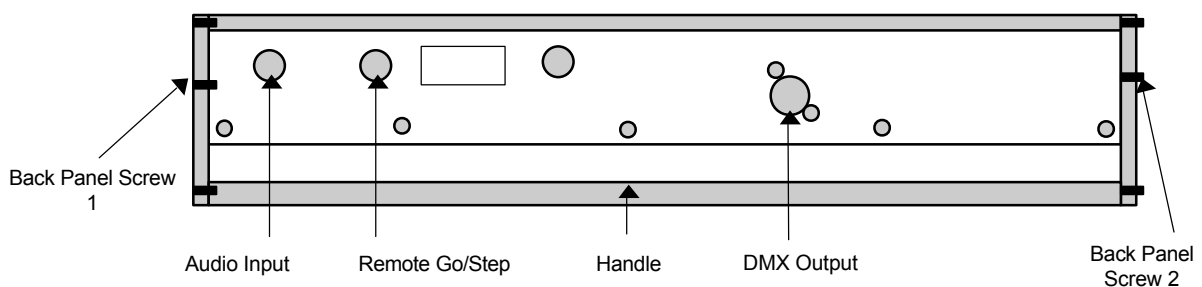

Fig 3 - Back Panel (not inverted)

Remove the 4 screws from the main PCB and replace with the 4 metal spacers provided (see fig 4). Retain the screws. Position the analogue PCB above the main PCB and ensure that the pins on the analogue PCB are correctly inserted into the holes in the main PCB (fig 4). Secure the analogue PCB to the spacers using the 4 screws originally removed from the main PCB.

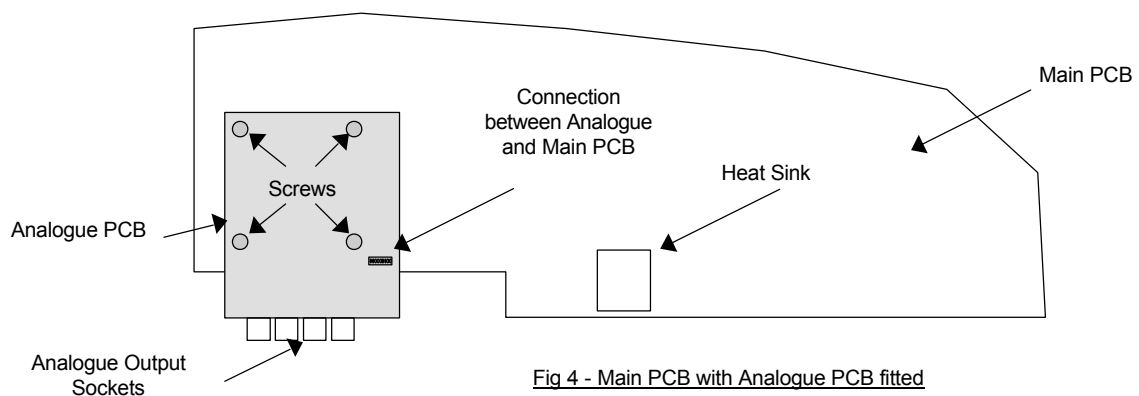

Fig 4 - Main PCB with Analogue PCB fitted

Connect the DMX output socket to the back panel supplied in the kit. Fit the back panel into the desk, ensuring it is seated properly. Refit the base panel onto the desk, being careful not to trap the wires from the DMX output socket.

Secure the back panel to the base panel using the five screws removed earlier. Secure the back panel to the sides using the two screws. Refit the washers and nuts on the Audio Input and Remote Go/Step sockets on the back panel.

Instructions for Alcora/Elara 12 Mk1 (grey panel) Revision C

Discard the Back Panel from the kit, it is not needed on this revision of the desk.

Ensure that the desk is switched off. Disconnect the power supply unit, DMX output cable, audio input, remote go/step and memory module, if connected. Turn the desk upside down and rest on suitable supports (e.g. foam rubber). **Do not rest the desk on the fader knobs as this may damage the faders.**

Remove the nuts and washers from the Audio Input and Remote Go/Step sockets on the back panel and remove the two screws holding the back panel to the sides (see fig 5). Remove the five screws holding the back panel to the base panel (fig 5).

Lift the base panel up slightly and then pull it towards the handle so that it comes out of the groove in the underside of the desk. Remove the base panel completely.

It is not necessary to completely remove the back panel, however it must be moved slightly away from the main PCB by lifting it slightly and pulling it towards the handle. Remove the 4 blanking plugs from the back panel.

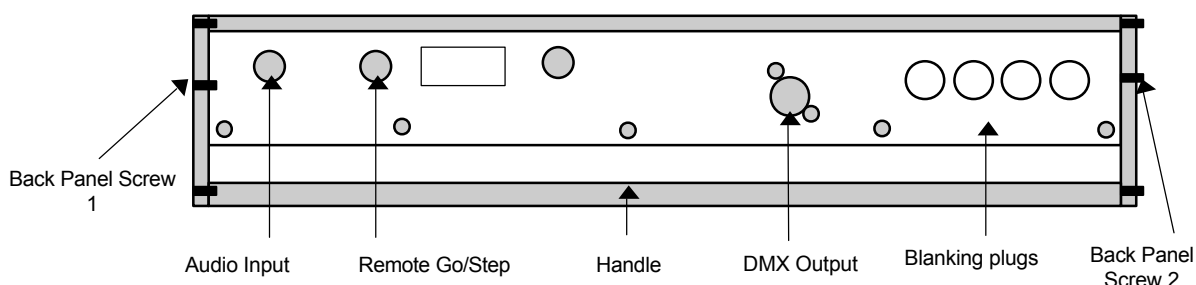

Fig 5 - Back Panel (not inverted)

Remove the 4 screws from the main PCB and replace with the 4 metal spacers provided (see fig 6). Retain the screws. Position the analogue PCB above the main PCB and ensure that the pins on the analogue PCB are correctly inserted into the holes in the main PCB (fig 6). Secure the analogue PCB to the spacers using the 4 screws originally removed from the main PCB.

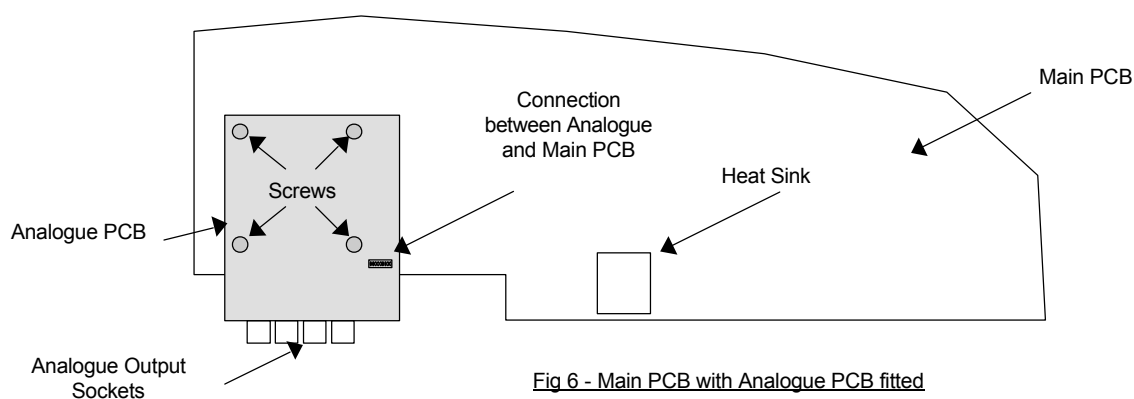

Fig 6 - Main PCB with Analogue PCB fitted

Replace the back panel into the desk, ensuring it is seated properly. Refit the base panel onto the desk, being careful not to trap the wires from the DMX output socket.

Secure the back panel to the base panel using the five screws removed earlier. Secure the back panel to the sides using the two screws. Refit the washers and nuts on the Audio Input and Remote Go/Step sockets on the back panel.

Instructions for Alcora/Elara 12 Mk2 (blue/green panel)

Ensure that the desk is switched off. Disconnect the power supply unit, DMX output cable, audio input, remote go/step and memory module, if connected.

Remove the two screws holding the front panel assembly to the base tray (see fig 7). Ease the front panel assembly away from the base tray, and place the front panel assembly to one side. Note that the front panel assembly will remain connected to the control PCB in the base tray PCB by a ribbon cable. Take care not to damage this cable.

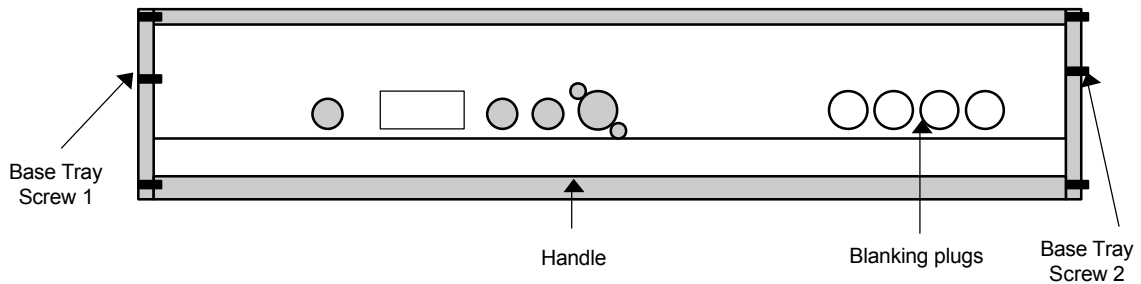

Fig 7 – Rear View

Remove the 4 blanking plugs from the base tray. Fit the analogue PCB into the base tray and secure using the 4 screws provided (see fig 8). Using the 16-way ribbon cable provided, connect the analogue PCB to the connector marked 'Analogue' on the control PCB in the base tray. Secure the ribbon cable at each end using the clips provided.

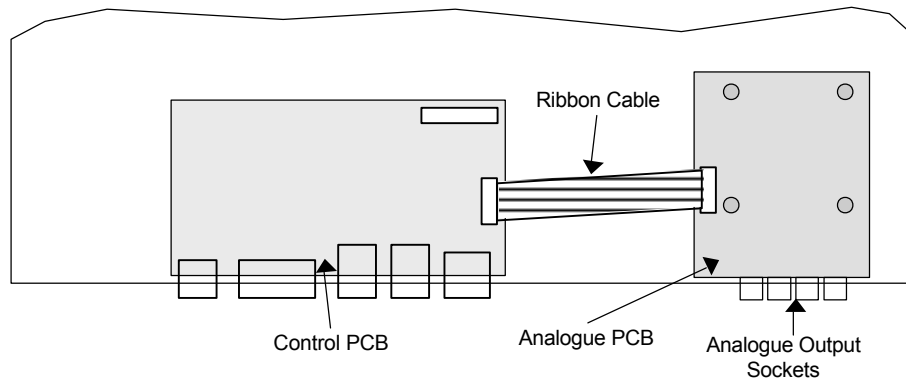

Fig 8 – Inside the Base Tray

Ensure that the DIP switch on the Analogue PCB has only the switch marked '1-24' in the ON (down) position. The other 3 switches must be in the OFF (up) position.

Re-fit the front panel assembly to the base tray, being careful not to trap the ribbon cable linking them. Secure the front panel assembly to the base tray using the two screws.

Instructions for Alcora/Elara 24 Mk2 (blue/green panel)

Ensure that the desk is switched off. Disconnect the power supply unit, DMX output cable, audio input, remote go/step and memory module, if connected.

Remove the two screws holding the front panel assembly to the base tray (see fig 9). Ease the front panel assembly away from the base tray, and place the front panel assembly to one side. Note that the front panel assembly will remain connected to the control PCB in the base tray PCB by a ribbon cable. Take care not to damage this cable.

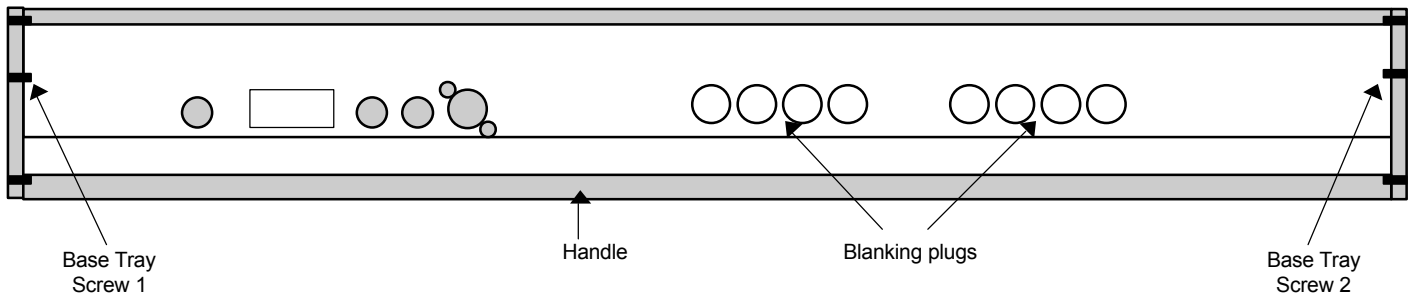

Fig 9 – Rear View

Remove the 8 blanking plugs from the base tray. Fit the 2 analogue PCBs into the base tray and secure using the 8 screws provided (see fig 10).

The DIP switches on the Analogue PCBs must be correctly set to address the boards:

- ?? On the PCB for channels 1-24, the switch marked '1-24' must be in the ON (down) position. The other 3 switches must be in the OFF (up) position.
- ?? On the PCB for channels 25-48, the switch marked '25-48' must be in the ON (down) position. The other 3 switches must be in the OFF (up) position.

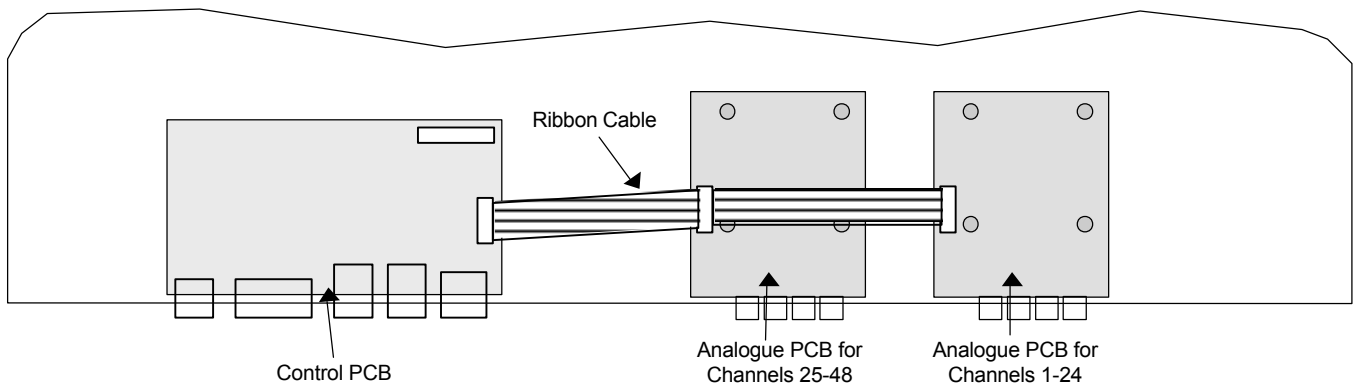

Fig 10 – Inside the Base Tray

Using the 16-way ribbon cable provided, connect the 2 analogue PCBs to the connector marked 'Analogue' on the control PCB in the base tray. Secure the ribbon cable at the three connectors using the clips provided.

Re-fit the front panel assembly to the base tray, being careful not to trap the ribbon cable linking them. Secure the front panel assembly to the base tray using the two screws.