

Showline

SL BEAM 100 LED LUMINAIRE



www.vari-lite.com

The material in this manual is for information purposes only and is subject to change without notice. Showline assumes no responsibility for any errors or omissions which may appear in this manual. For comments and suggestions regarding corrections and/or updates to this manual, please contact your nearest Showline office.

El contenido de este manual es solamente para información y está sujeto a cambios sin previo aviso. Showline no asume responsabilidad por errores o omisiones que puedan aparecer. Cualquier comentario, sugerencia o corrección con respecto a este manual, favor de dirigirlo a la oficina de Showline más cercana.

Der Inhalt dieses Handbuches ist nur für Informationszwecke gedacht, Aenderungen sind vorbehalten. Showline uebernimmt keine Verantwortung für Fehler oder Irrtuemer, die in diesem Handbuch auftreten. Für Bemerkungen und Verbesserungsvorschlaege oder Vorschlaege in Bezug auf Korrekturen und/oder Aktualisierungen in diesem Handbuch, moechten wir Sie bitten, Kontakt mit der naechsten Showline-Niederlassung aufzunehmen.

Le matériel décrit dans ce manuel est pour information seulement et est sujet à changements sans préavis. La compagnie Showline n'assume aucune responsabilité sur toute erreur ou ommission inscrite dans ce manuel. Pour tous commentaires ou suggestions concernant des corrections et/ou les mises à jour de ce manuel, veuillez s'il vous plait contacter le bureau de Showline le plus proche.

Note: Information contained in this document may not be duplicated in full or in part by any person without prior written approval of Showline. Its sole purpose is to provide the user with conceptual information on the equipment mentioned. The use of this document for all other purposes is specifically prohibited.

Document Number: **SL BEAM 100 LED Luminaires Users**

Version as of: 18th July, 2014

SL BEAM 100 LED Luminaire Installation & User's Manual

©2014 Philips Group. All rights reserved.

IMPORTANT INFORMATION

Warnings and Notices

When using electrical equipment, basic safety precautions should always be followed including the following:



- a. **READ AND FOLLOW ALL SAFETY INSTRUCTIONS**
- b. Do not use outdoors.
- c. Do not mount near gas or electric heaters.
- d. Equipment should be mounted in locations and at heights where it will not readily be subjected to tampering by unauthorized personnel.
- e. The use of accessory equipment not recommended by the manufacturer may cause an unsafe condition.
- f. Do not use this equipment for other than intended use.
- g. Refer service to qualified personnel.

SAVE THESE INSTRUCTIONS.



WARNING: You must have access to a main circuit breaker or other power disconnect device before installing any wiring. Be sure that power is disconnected by removing fuses or turning the main circuit breaker off before installation. Installing the device with power on may expose you to dangerous voltages and damage the device. A qualified electrician must perform this installation.

WARNING: Refer to National Electrical Codes and local codes for cable specifications. Failure to use proper cable can result in damage to equipment or danger to personnel.

WARNING: This equipment is intended for installation in accordance with the National Electric Code® and local regulations. It is also intended for installation in indoor applications only. Before any electrical work is performed, disconnect power at the circuit breaker or remove the fuse to avoid shock or damage to the control. It is recommended that a qualified electrician perform this installation.

Additional Resources for DMX512

For more information on installing DMX512 control systems, the following publication is available for purchase from the United States Institute for Theatre Technology (USITT), "Recommended Practice for DMX512: A Guide for Users and Installers, 2nd edition" (ISBN: 9780955703522). USITT Contact Information:

USITT
315 South Crouse Avenue, Suite 200
Syracuse, NY 13210-1844
Phone: 1.800.938.7488 or 1.315.463.6463
www.usitt.org

Showline Limited Two-Year Warranty

Showline offers a two-year limited warranty of its luminaires against defects in materials or workmanship from the date of delivery. A copy of Showline two-year limited warranty containing specific terms and conditions can be obtained by contacting your local Showline office.

TABLE OF CONTENTS

Showline Offices	0
IMPORTANT INFORMATION	
Warnings and Notices	1
Additional Resources for DMX512	1
Showline Limited Two-Year Warranty	1
TABLE OF CONTENTS	
PREFACE	
About this Manual	3
Included Items	3
Accessories	3
SL BEAM 100 LED Luminaire Power Input Cables	3
SL BEAM 100 LED Luminaire Accessories	3
SL BEAM 100 LED LUMINAIRE OVERVIEW	
SL BEAM 100 LED Luminaire Components	4
Major Luminaire Components	4
LCD Display / Menu System	5
INSTALLATION AND SET UP	
Power Requirements	6
AC Power Operation	6
Connecting Power	6
Connecting SL BEAM 100 LED Luminaires to AC Power	6
Connecting to the DMX512 Network	7
Mounting Luminaire	8
OPERATION AND PROGRAMMING	
LCD Display and Menu System	9
LCD Display and Menu System Operation	9
Menu Tree	10
Quick Selection Buttons	11
Edit a Preset Button	11
Edit a Chase Button	11
DMX Address Button	11
Dimming Curve Selection	12
Master / Slave Operational Mode	13
DMX CONTROL	
Simple 8-bit Mode	14
Simple 8-bit Group Mode	15
RGBW 8-bit Mode	15
RGBW 8-bit Group Mode	19
RGBW 16-bit Mode	19
RGBW 16-bit GroupMode	23
HSIC Mode	24
HSIC GroupMode	25
SL BEAM 100 LED Luminaire DMX Timing Channel Details	26
SL BEAM 100 LED Luminaire RDM Parameter IDs	32
CLEANING AND CARE	
Special Cleaning and Care Instructions	36
Front Lens Cleaning	36
Service and Maintenance	36
TECHNICAL SPECIFICATIONS	
SL BEAM 100 LED Luminaire Operational Specifications	37
SL BEAM 100 LED Luminaire Dimensions	37

PREFACE

1. About this Manual

The document provides installation and operation instructions for the following products:

- SL BEAM 100 LED Luminaire

Please read all instructions before installing or using this product. *Retain this manual for future reference.* Additional product information and descriptions may be found on the product specification sheet.

Note: The SL BEAM 100 LED Luminaire is universal voltage 100 to 240 VAC (auto-ranging).

2. Included Items



Each SL BEAM 100 LED Luminaire includes the following items:

- SL BEAM 100 LED Luminaire
- SL BEAM 100 Quick Start Guide

3. Accessories

SL BEAM 100 LED Luminaire Power Input Cables

Part Number	Description
17-003-0054-00	SL BEAM 100 LED Luminaire AC Power Input Cable (1.5 meter)

SL BEAM 100 LED Luminaire Accessories

Part Number	Description
60-600-0134-00	Camp Lock for SL BEAM 100 LED Luminaire

SL BEAM 100 LED LUMINAIRE OVERVIEW

1. SL BEAM 100 LED Luminaire Components

Major Luminaire Components

Top of Unit

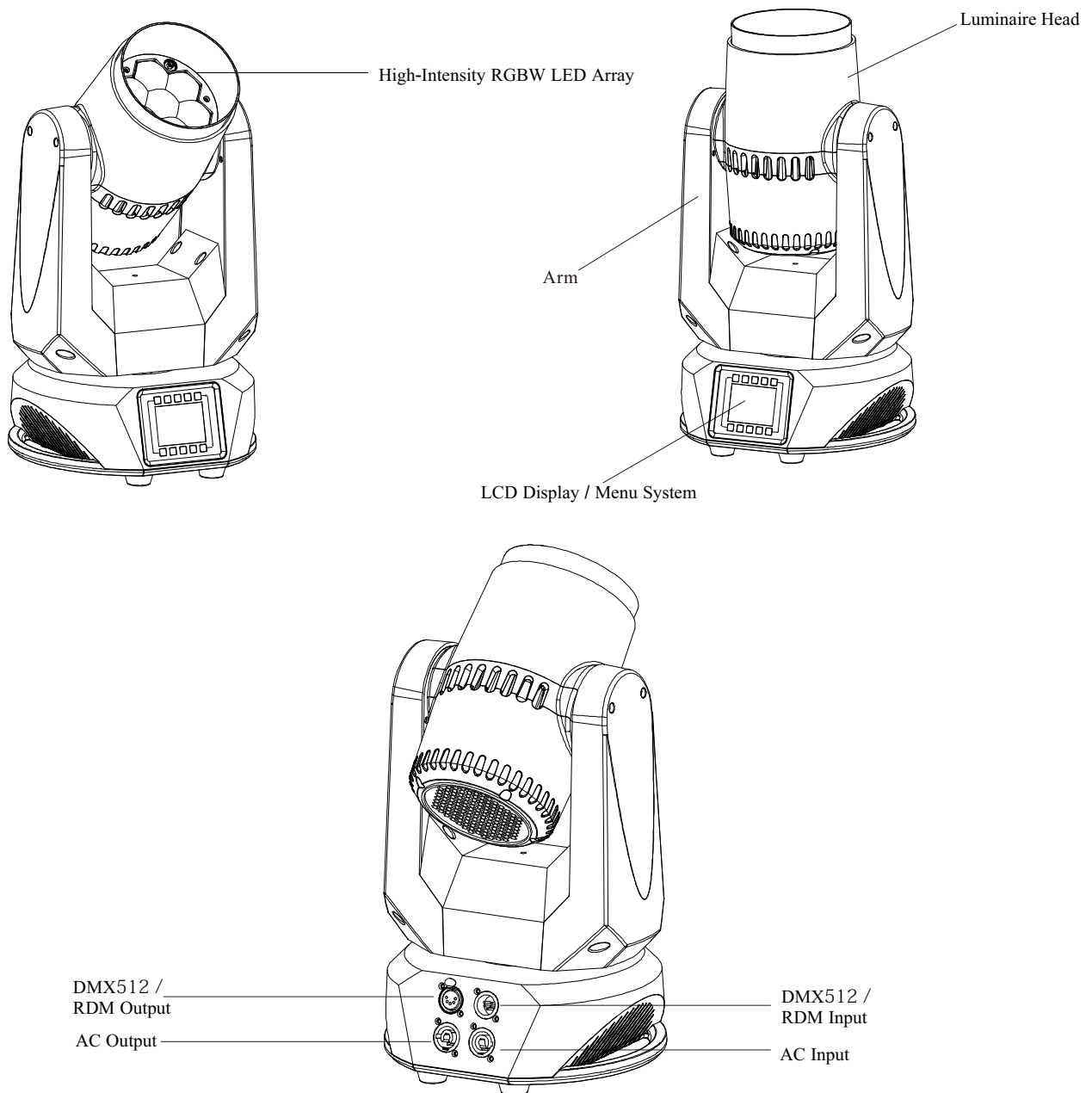
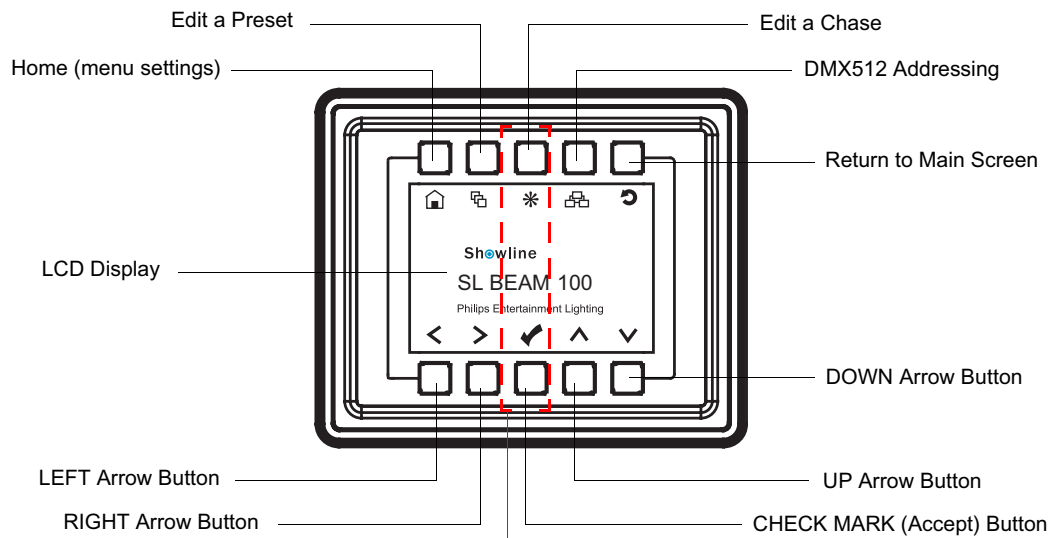

Figure 1: SL BEAM 100 LED Luminaire Components

Note: *Mounts can be removed and reversed. See "[Mounting Luminaire](#)" on page 8 for more information.

LCD Display / Menu System



NOTE: Menu rotates with orientation of luminaire and menu buttons are always in the same position (with rotation of menu)

To rotate menu 180 degrees from current orientation, press and hold the two center buttons for 2 seconds.

Figure 2: LCD Display & Menu System

Note: For Menu operation and programming details, refer to "LCD Display and Menu System" on page 9.

INSTALLATION AND SET UP

1. Power Requirements

The SL BEAM 100 LED Luminaire operates on AC input voltages from 100 to 240 VAC.



WARNING! This unit does not contain an ON/OFF switch. Always disconnect power input cable to completely remove power from unit when not in use.

AC Power Operation

When connected to an AC source, the unit operates on 100 to 240 volts AC (+/- 10%, auto-ranging). The luminaire contains an auto-ranging power supply. Each luminaire can draw up to 150 Watts.



WARNING! Maximum amount of units that may be daisy-chained is (A) 11 units 100 ~ 120VAC (15 Amps) or (B) 20 units 230 ~ 240VAC (15 Amps).

Table 1: SL BEAM 100 LED Luminaire Voltage (VAC) vs. Current*

Voltage (AC)	Total Current (A)	Voltage (AC)	Total Current (A)
100	1.50	180	0.83
110	1.36	190	0.78
120	1.25	200	0.75
130	1.15	210	0.71
140	1.07	220	0.68
150	1.00	230	0.65
160	0.93	240	0.62
170	0.88		

Note: For wiring of AC input connector, refer to "[Connecting SL BEAM 100 LED Luminaires to AC Power](#)" on page 6.

2. Connecting Power

Units can be powered in one of two ways:

- Direct connection to a AC power source using an AC input cable.
- Connection from the AC output of another SL BEAM 100 LED Luminaire. When using this method, it is very important not to connect any other type of equipment device.



WARNING! Only connect other SL BEAM 100 LED Luminaires to the AC Output (Thru) connector of a SL BEAM 100 LED Luminaire.

Connecting SL BEAM 100 LED Luminaires to AC Power

Figure 3 on page 7 describes how to connect power to your SL BEAM 100 LED Luminaire. Field wiring of the SL BEAM 100 LED Luminaire is straight forward. A total of 3 wires/conductors is supplied from the unit. The following wiring scheme is used:

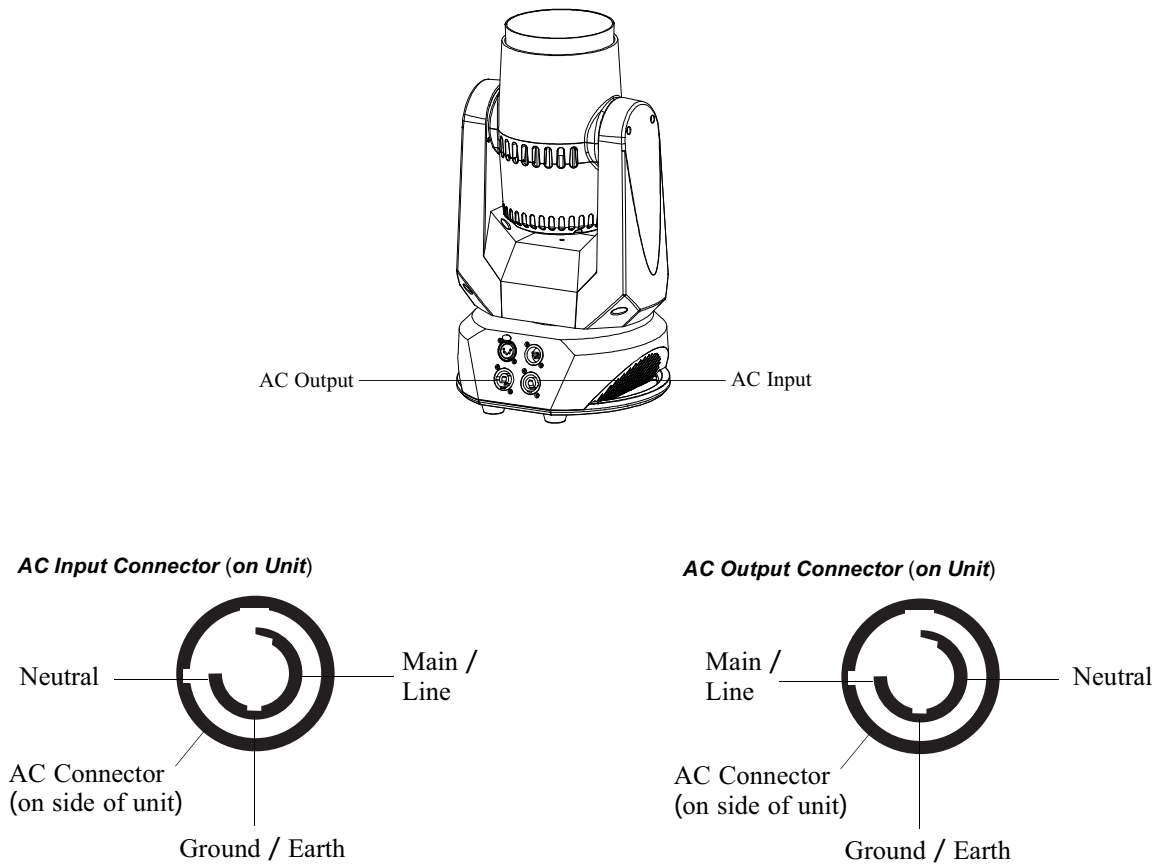

Figure 3: SL BEAM 100 LED Luminaire AC Input & Output Connections

CAUTION: In the event the AC input cable of this luminaire is damaged, it must be replaced, by the user, with an approved cable through an Authorized Showline Dealer or Service Center.

3. Connecting to the DMX512 Network

Basic DMX512 installation consists of connecting multiple SL BEAM 100 LED Luminaires together (up to 32 luminaires) in "daisy-chain" fashion. A cable runs from the control console (or DMX512 control source) to the DMX connector on the first SL BEAM 100 LED Luminaire. Another cable runs from the other DMX connector on the first unit to a DMX connector on the next SL BEAM 100 LED Luminaire (or DMX512 device to be controlled).

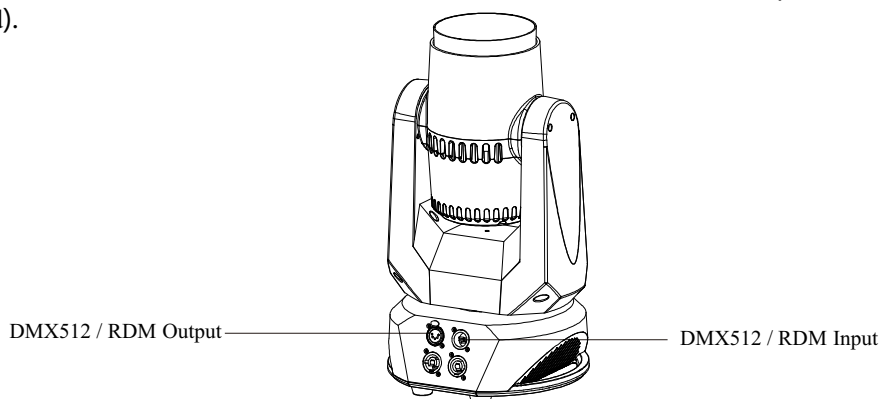

Figure 4: SL BEAM 100 LED Luminaire DMX512 Input / Output Connections

Note: For more information on DMX512 networking and systems, refer to "Additional Resources for DMX512" on page 1. For SL BEAM 100 LED Luminaire DMX Mapping, refer to "DMX CONTROL" on page 14.

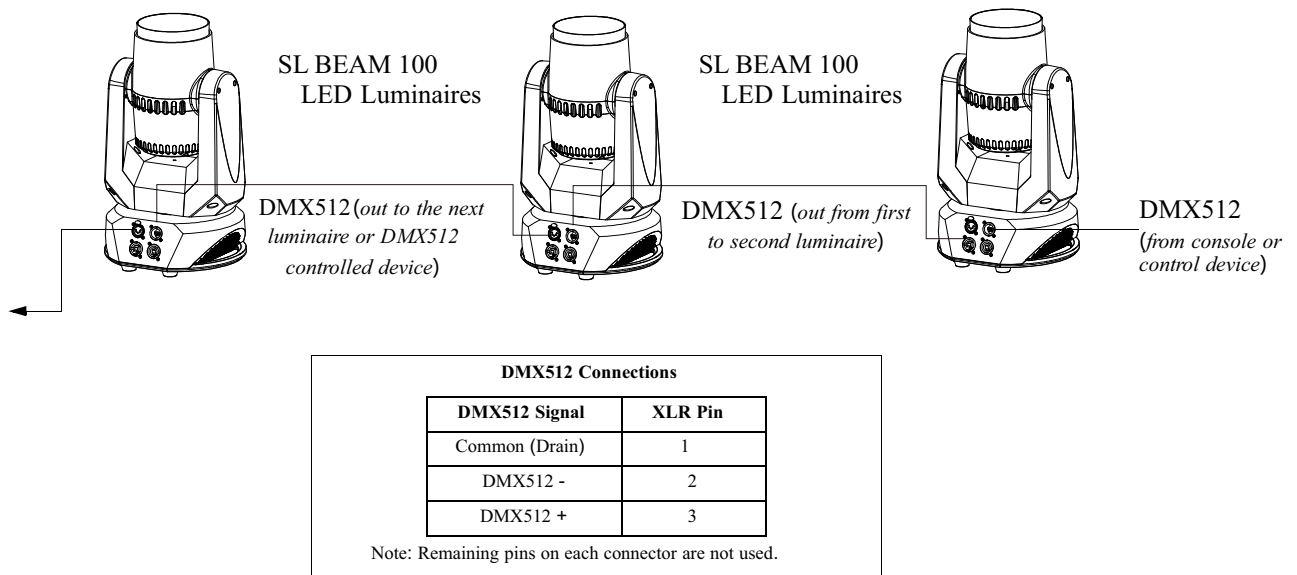

Figure 5: SL BEAM 100 LED Luminaire - DMX512 Connections

4. Mounting Luminaire

The SL BEAM 100 LED Luminaire is provided with two mounts and safety cable anchor points.

The two mounts are easily removed and reversed as required. These mounts are designed to accept a variety of mounting hooks, clamps, etc. for hanging applications. Refer to **Figure 6** for additional information. *Note, the bottom of the luminaire must be free and clear of any objects (i.e., scenery) to allow for proper airflow* Simply attach hook, clamp, etc. to the SL BEAM 100 LED Luminaire mount assembly in the M13 hole.

Note: Mounting hooks, clamps, etc. are sold separately or by others. For available mounting accessories refer to "Accessories" on page 3.

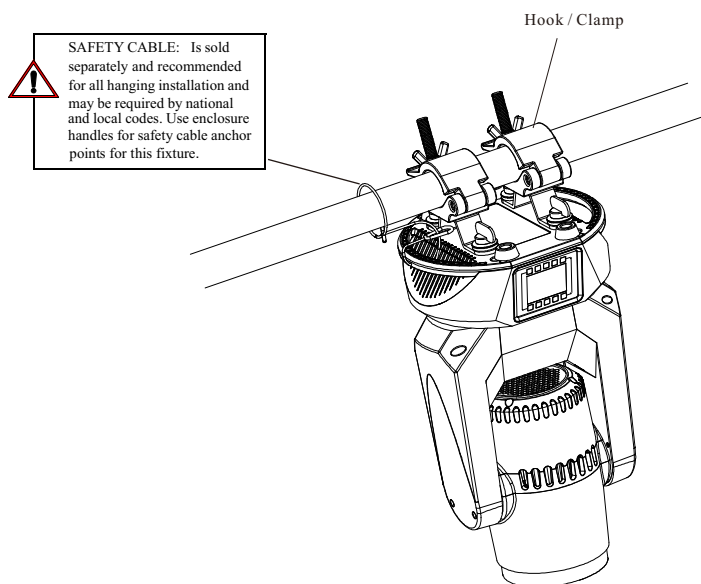

Figure 6: Mounting Luminaire - Hanging Applications

OPERATION AND PROGRAMMING

1. LCD Display and Menu System

The SL BEAM 100 LED Luminaire's LCD Display and Menu System provides local control for accessing the following fixture's settings:

- Presets (Standard and User Defined)
- Color Filters
- Effects (Chases - preloaded and user defined)
- Strobe / Timing
- Settings
- Lock Fixture (to prevent changes)
- Password
- Status
- Setting the DMX512 Address

Note: If there are multiple luminaires in a system, changes would need to be made at each LCD Menu as desired.

Upon power up, the LCD will display the main screen showing the product type/name. If DMX is enabled, the programmed address will appear after power up.

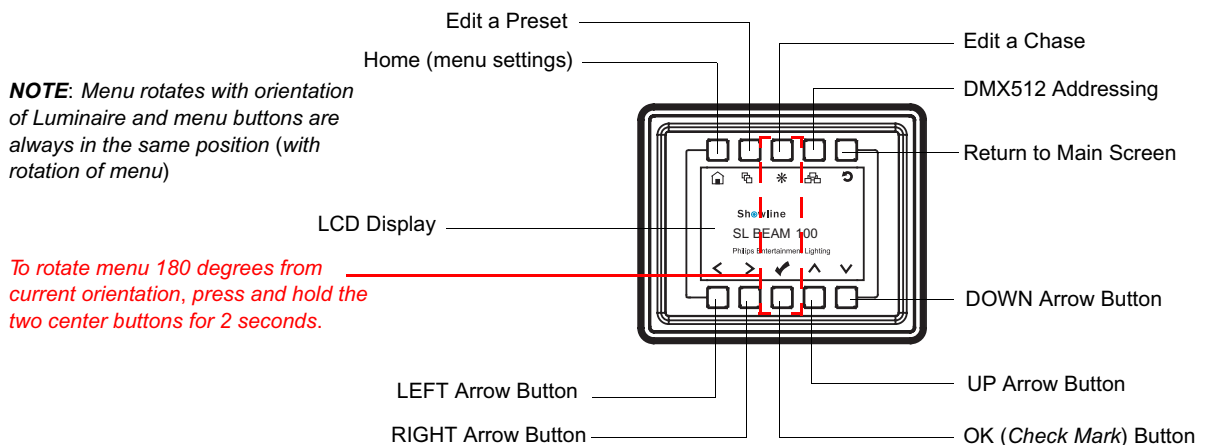

Figure 7: LCD Display and Menu System

2. LCD Display and Menu System Operation

The LCD Display Menu system consists of several categories. Use the Menu Buttons to access and make changes to the menu items. When the desired menu item is reached, press the desired Menu Button to display the menu options and to navigate and configure the menu options as required.

To navigate and access menu settings/selections:

- Step 1. Make sure unit is powered and turned on.
- Step 2. Press the desired button (as shown in **Figure 7**) to access menu categories.
- Step 3. Use UP | DOWN | LEFT | RIGHT arrow buttons to navigate through the various options and settings.
- Step 4. Make changes as desired.
- Step 5. Press CHECK MARK (OK) button to accept changes.

3. Quick Selection Buttons

When in Manual Mode, the SL NITRO LED Luminaire's features can be accessed via the on-board LCD menu system or via three quick select buttons:

- Edit a Preset Button
- Edit a Chase Button
- DMX Address Button

Edit a Preset Button

To edit and save a preset:

- Step 1. Press Edit a Preset button. Current preset will be shown.
- Step 2. Use LEFT and RIGHT arrow buttons to scroll through all presets.
- Step 3. Once at desired preset, use UP and DOWN arrows to access (highlight) preset parameters. Once in desired parameter, use LEFT and RIGHT arrow buttons to adjust parameter value as desired.
- Step 4. Once all values are adjusted as desired, press OK (Check Mark) button.
- Step 5. Save preset menu option will appear. Use LEFT and RIGHT arrow button to select preset number.
- Step 6. If saving preset, press OK (Check Mark) button. Confirm choice.
- Step 7. Preset is now saved.

Edit a Preset

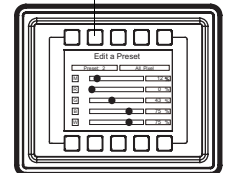

Edit a Chase Button

To edit and save a chase:

- Step 1. Press Edit a Chase button. Current chase will be shown.
- Step 2. Use LEFT and RIGHT arrow buttons to scroll through all chases (Built In and User Chases).

Edit a Chase

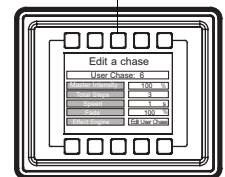

Note: For Built In Chases, only the Speed, the Master Intensity and Fade parameters may be changed and saved. For User Chases, Chase Number, Total Steps, Speed, and Fade Parameters may be changed and saved.

- Step 3. Once at desired chase, use UP and DOWN arrows to access (highlight) chase parameters. Once in desired parameter, use LEFT and RIGHT arrow buttons to adjust parameter value as desired.
- Step 4. Once all values are adjusted as desired, press OK (Check Mark) button.
- Step 5. Save chase menu option will appear. Use LEFT and RIGHT arrow buttons to select chase number.
- Step 6. If saving chase, press OK (Check Mark) button. Confirm choice.
- Step 7. Chase is now saved.

DMX Address Button

To edit and save a DMX address:

- Step 1. Press DMX Address button. Current DMX Address will be shown.
- Step 2. Press OK (Check Mark) button to highlight a digit in the DMX address.
- Step 3. Use LEFT and RIGHT arrow buttons to scroll through all digits.
- Step 4. Once at desired digit, use UP and DOWN arrows to change highlighted digit. Once digit is set, use LEFT and RIGHT arrow buttons to set other digits in DMX address.
- Step 5. Once all digits are set in DMX address, press OK (Check Mark) button.
- Step 6. DMX will display and is saved.

DMX Address



4. Dimming Curve Selection

Through the menu, you are able to select one of four dimming curves:

- Linear Curve
- PL_Curve
- S_Curve
- Square Curve

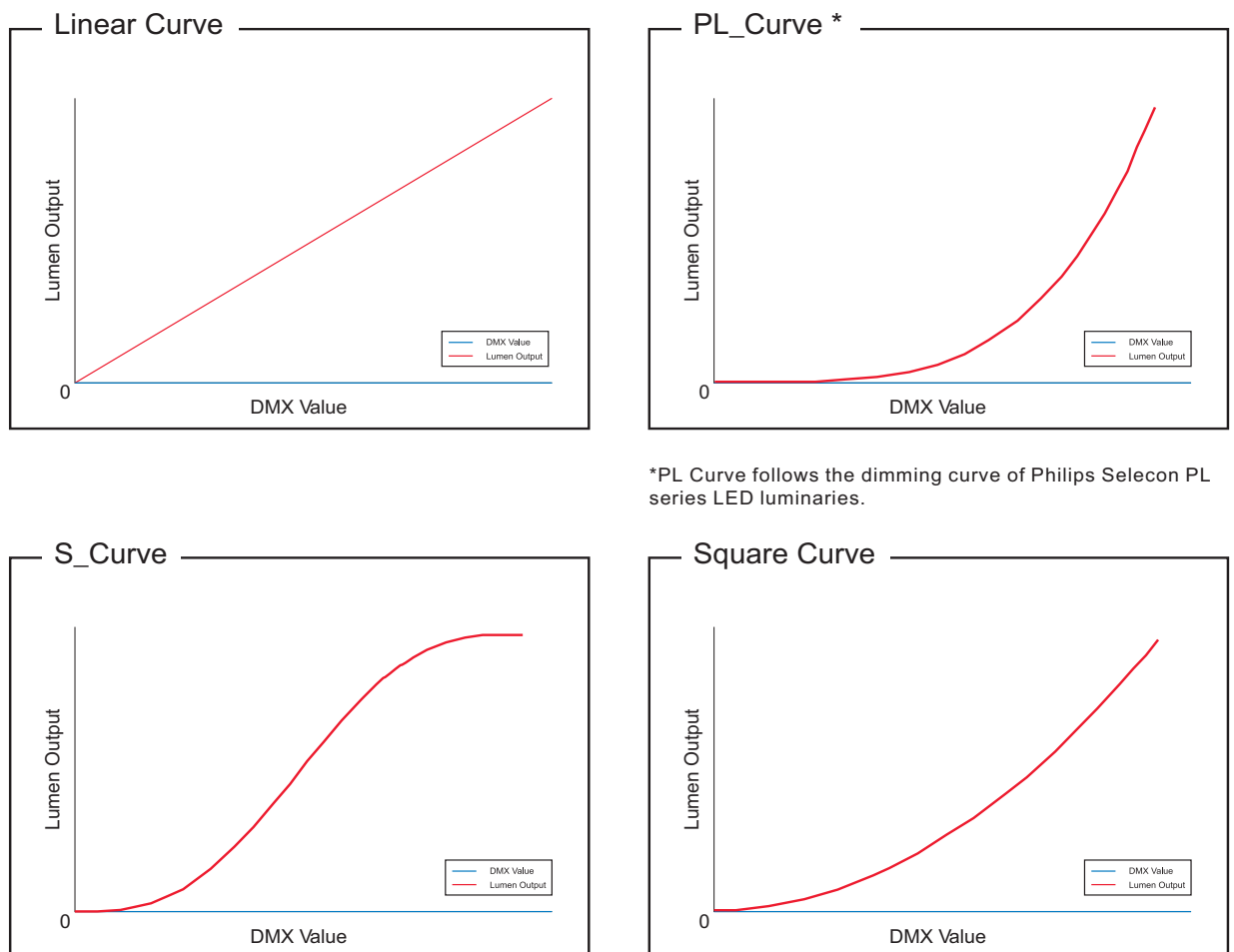

Figure 9: SL BEAM 100 LED Luminaire Dimmer Curves

5. Master / Slave Operational Mode

The Master / Slave Operational Mode allows one SL BEAM 100 LED Luminaire to act as the "Master" unit and all other connected units are controlled by this unit. When a unit is set to "Slave" mode, it will only listen to and follow any commands sent from a "Master" unit. Only one "Master" unit is allowed in this type of operation.

To setup a master / slave network:

- Step 1. Set the first device in the DMX512 chain to **Master Mode** through the unit's menu system.
- Step 2. Set all other connected units to **Slave Mode**.
- Step 3. The master unit can be controlled via DMX512, RDM or through standalone operation (self-contained network utilizing on-board effects). The slave units will mimic the master unit's operation in all cases.

Note: For more information on DMX512 networking and systems, refer to ["Additional Resources for DMX512" on page 1](#). For SL BEAM 100 LED Luminaire DMX Mapping, refer to ["DMX CONTROL" on page 14](#).

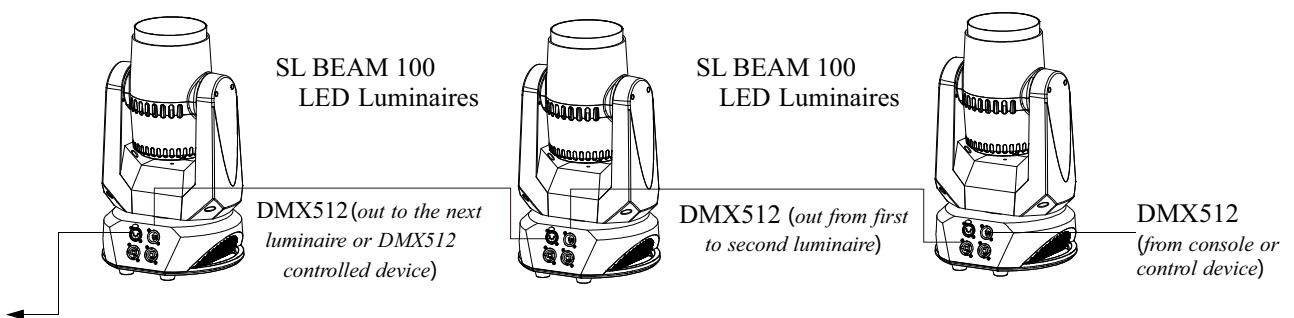

Figure 10: SL BEAM 100 LED Luminaire - Master / Slave Configuration

DMX CONTROL

This section contains information for operating the luminaire using DMX control in Simple 8-bit, RGBW 8-bit, RGBW 16-bit, and HSIC modes. For Menu options and detailed information, see "[LCD Display and Menu System](#)" on page 9.

Note: These tables assume a DMX start address of 1. When a different starting address is used, this address becomes channel 1 function and other functions follow in sequence.

1. Simple 8-bit Mode

Table 2 provides DMX channel mapping of all DMX512 control values when the SL BEAM 100 LED Luminaire is in Simple 8-bit mode (as set by the luminaire's menu system).

Table 2: SL BEAM 100 LED Luminaire DMX Channel Mapping (Simple 8-bit Mode)

DMX	Parameter	Range DMX	Range %	Defaults	Description
1	Pan - High Byte	0 - 255	0 - 100%	128	8-bit control of Pan
2	Tilt - High Byte	0 - 255	0 - 100%	128	8-bit control of Tilt
3	Master Intensity	0 - 255	0 - 100%	0	8 bit control for Intensity of LED settings.
4	Strobe	0 - 255	0 - 100%	0	Controls strobe operations as follows . . . Open = DMX 0 - 2 Closed = DMX 3 - 5 Slow Rand = DMX 6 - 7 Med Rand = DMX 8 - 10 Fast Rand = DMX 11 - 12 Strobe Range = DMX 13 - 127 (fastest) Pulse + Slow Rand = DMX 128 - 129 Pulse + Med Rand = DMX 130 - 131 Pulse + Fast Rand = DMX 132 - 133 Pulse + Range = DMX 134 - 191 Pulse - Slow Rand = DMX 192 - 193 Pulse - Med Rand = DMX 194 - 195 Pulse - Fast Rand = DMX 196 - 197 Pulse - Range = DMX 198 - 255
5	Zoom	0 - 255	0 - 100%	0	Variable control of zoom from 12 ⁰ - 45 ⁰
6	Control	0 - 255	0 - 100%	0	Functions of the SL Series products. Set control channel value to desired action, Hold value for at least 5 seconds, then turn to 0. Set control channel value to 0 without any scaling. Default Setting on Console = DMX 0-4 DIM Response_Normal = DMX 5 - 9 DIM Response_Incandescent = DMX 10 - 14 Dimming Curve_linear = DMX 30 - 34 Dimming Curve_Square = DMX 35- 39 Dimming Curve_S-Curve = DMX 40 - 44 Dimming Curve_PL-Curve = DMX 45 - 49 Calibration_OFF = DMX 70 - 74 Calibration_ON = DMX 75 - 79 Fan_Auto = DMX 80 - 84 Fan_Off = DMX 85 - 89 Reserves(Future use) = DMX 90 - 250
7	Red1-3	0 - 255	0 - 100%	0	8 bit control of Red LEDs from 0 to full.
8	Green1-3	0 - 255	0 - 100%	0	8 bit control of Green LEDs from 0 to full.
9	Blue1-3	0 - 255	0 - 100%	0	8 bit control of Blue LEDs from 0 to full.
10	White1-3	0 - 255	0 - 100%	0	8 bit control of White LEDs from 0 to full.

2. Simple 8-bit Group Mode

Table 3 provides DMX channel mapping of all DMX512 control values when the SL BEAM 100 LED Luminaire is in Simple 8-bit Group mode (as set by the luminaire's menu system).

Table 3: SL BEAM 100 LED Luminaire DMX Channel Mapping (Simple 8-bit Group Mode)

Simple 8 BIT MODE		
DMX CHANNEL	3 Group MODE	1 Group MODE
1	Pan	Pan
2	Tilt	Tilt
3	Master Intensity	Master Intensity
4	Strobe	Strobe
5	Zoom	Zoom
6	Control	Control
7	Red_1	Red_1-3
8	Green_1	Green_1-3
9	Blue_1	Blue_1-3
10	White_1	White_1-3
11	Red_2	
12	Green_2	
13	Blue_2	
14	White_2	
15	Red_3	
16	Green_3	
17	Blue_3	
18	White_3	

3. RGBW 8-bit Mode

Table 4 provides DMX channel mapping of all DMX512 control values when the SL BEAM 100 LED Luminaire is in RGBW 8-bit mode (as set by the luminaire's menu system).

Table 4: SL BEAM 100 LED Luminaire DMX Channel Mapping (RGBW 8-bit Mode)

DMX	Parameter	Range DMX	Range %	Defaults	Description
1	Pan	0 - 255	0 - 100%	128	8-bit control of Pan
2	Tilt	0 - 255	0 - 100%	128	8-bit control of Tilt
3	Master Intensity - High	0 - 255	0 - 100%	0	8 bit control for Intensity of LED settings.
4	Color Presets	0 - 255	0 - 100%	0	Variable color Presets as follows . . . Channel OFF (disabled) DMX 0 - 4 Preset 0 (OFF) DMX 5 - 6 Preset 1 DMX 7 - 8 Preset 2 DMX 9 - 10 Preset 3 DMX 11 - 12 Preset 4 DMX 13 - 14 Preset 5 DMX 15 - 16 Preset 6 DMX 17 - 18 Preset 7 DMX 19 - 20 Preset 8 DMX 21 - 22 Preset 9 DMX 23 - 24 Preset 10 DMX 25 - 26

Table 4: SL BEAM 100 LED Luminaire DMX Channel Mapping (RGBW 8-bit Mode)

				Preset 11	DMX 27 - 28
				Preset 12	DMX 29 - 30
				Preset 13	DMX 31 - 32
				Preset 14	DMX 33 - 34
				Preset 15	DMX 35 - 36
				Preset 16	DMX 37 - 38
				Preset 17	DMX 39 - 40
				Preset 18	DMX 41 - 42
				Preset 19	DMX 43 - 44
				Preset 20	DMX 45 - 46
				Preset 21	DMX 47 - 48
				Preset 22	DMX 49 - 50
				Preset 23	DMX 51 - 52
				Preset 24	DMX 53 - 54
				Preset 25	DMX 55 - 56
				Preset 26	DMX 57 - 58
				Preset 27	DMX 59 - 60
				Preset 28	DMX 61 - 62
				Preset 29	DMX 63 - 64
				Preset 30	DMX 65 - 66
				Preset 31	DMX 67 - 68
				CF_0_Color OFF	DMX 69 - 70
				CF_1_White 10000K	DMX 71 - 72
				CF_2_White 8000K	DMX 73 - 74
				CF_3_White 6500K	DMX 75 - 76
				CF_4_White 5600K	DMX 77 - 78
				CF_5_White 5000K	DMX 79 - 80
				CF_6_White 4500K	DMX 81 - 82
				CF_7_White 4000K	DMX 83 - 84
				CF_8_White 3200K	DMX 85 - 86
				CF_9_White 3000K	DMX 87 - 88
				CF_10_White 2700K	DMX 89 - 90
				CF_11_Moroccan Pink	DMX 91 - 92
				CF_12_Pink	DMX 93 - 94
				CF_13_Flesh Pink	DMX 95 - 96
				CF_14_Bright Rose	DMX 97 - 98
				CF_15_Follies Pink	DMX 99 - 100
				CF_16_Fuchsia Pink	DMX 101 - 102
				CF_17_Surprise Pink	DMX 103 - 104
				CF_18_Congo Blue	DMX 105 - 106
				CF_19_Blue	DMX 107 - 108
				CF_20_Virgin Blue	DMX 109 - 110
				CF_21_Midnight Maya	DMX 111 - 112
				CF_22_Dluble C.T Blue	DMX 113 - 114
				CF_23_Slate Blue	DMX 115 - 116
				CF_24_Regal Blue	DMX 117 - 118
				CF_25_Fullt C.T Blue	DMX 119 - 120
				CF_26_Steel Blue	DMX 121 - 122
				CF_27_Lighter Blue	DMX 123 - 124
				CF_28_Cyan	DMX 125 - 126
				CF_29_Marine Blue	DMX 127 - 128
				CF_30_Soft Green	DMX 129 - 130
				CF_31_Moss Green	DMX 131 - 132
				CF_32_Green	DMX 133 - 134
				CF_33_Fem Green	DMX 135 - 136
				CF_34_JAS Green	DMX 137 - 138
				CF_35_Pale Green	DMX 139 - 140
				CF_36_Spring Yellow	DMX 141 - 142
4	Color Presets		0		

Table 4: SL BEAM 100 LED Luminaire DMX Channel Mapping (RGBW 8-bit Mode)

4	Color Presets	0 - 255	0 - 100%	0	CF_37_Yellow DMX 143 - 144 CF_38_Deep Amber DMX 145 - 146 CF_39_Chrome Orange DMX 147 - 148 CF_40_Orange DMX 149 - 150 CF_41_Magenta DMX 151 - 152 CF_42_Flame Red DMX 153 - 154 CF_43_Purple DMX 155 - 156 Rotate CW Fast →Slow DMX 157 - 171 Rotate ACW Slow →Fast DMX 172 - 186 Random Color Fast →Slow DMX 187 - 201 Chase1 DMX 202 - 204 Chase2 DMX 205 - 207 Chase3 DMX 208 - 210 Chase4 DMX 211 - 213 Chase5 DMX 214 - 216 Chase6 DMX 217 - 219 Chase7 DMX 220 - 222 Chase8 DMX 223 - 225 Chase9 DMX 226 - 228 Chase10 DMX 229 - 231 User Chase1 DMX 232 - 234 User Chase2 DMX 235 - 237 User Chase3 DMX 238 - 240 User Chase4 DMX 241 - 243 User Chase5 DMX 244 - 246 User Chase6 DMX 247 - 249 User Chase7 DMX 250 - 252 User Chase8 DMX 253 - 255
5	Strobe	0 - 255	0 - 100%	0	Controls strobe operations as follows . . . Open DMX 0 - 2 Closed DMX 3 - 5 Slow Rand DMX 6 - 7 Med Rand DMX 8 - 10 Fast Rand DMX 11 - 12 Strobe Range DMX 13 - 127 (fastest) Pulse + Slow Rand DMX 128 - 129 Pulse + Med Rand DMX 130 - 131 Pulse + Fast Rand DMX 132 - 133 Pulse + Range DMX 134 - 191 Pulse - Slow Rand DMX 192 - 193 Pulse - Med Rand DMX 194 - 195 Pulse - Fast Rand DMX 196 - 197 Pulse - Range DMX 198 - 255
6	Duration	0 - 255	0 - 100%	0	Strobe's duration,Range is 0-85 0 DMX 0 1 DMX 1 - 3 x (DMX Value-1)/3+1 85 DMX 253-255

Table 4: SL BEAM 100 LED Luminaire DMX Channel Mapping (RGBW 8-bit Mode)

7	Zoom	0 - 255	0 - 100%	0	Variable control of zoom from 12 ⁰ - 45 ⁰ .
8	Focus Timing	0 - 255	0 - 100%	255	Timing control of Pan/Tilt
9	Timing	0 - 255	0 - 100%	255	Allows for timing control of intensity, color, and zoom parameters. Channel should default to 255 for smoothest actions using console and/or manual fades. - See Timing Chart for more details.
10	Control	0 - 255	0 - 100%	0	<p>Functions of the SL Series products. Set control channel value to desired action, Hold value for at least 5 seconds, then turn to 0. Set control channel value to 0 without any scaling.</p> <p>Default Setting on Console = DMX 0-4 DIM Response_Normal = DMX 5 - 9 DIM Response_Incandescent = DMX 10 - 14 Dimming Curve_linear = DMX 30 - 34 Dimming Curve_Square = DMX 35- 39 Dimming Curve_S-Curve = DMX 40 - 44 Dimming Curve_PL-Curve = DMX 45 - 49 Calibration_OFF = DMX 70 - 74 Calibration_ON = DMX 75 - 79 Fan_Auto = DMX 80 - 84 Fan_Off = DMX 85 - 89 Reserves(Future use) = DMX 90 - 250</p>
11	Red1-3	0 - 255	0 - 100%	0	8 bit control of Red LEDs from 0 to full.
12	Green1-3	0 - 255	0 - 100%	0	8 bit control of Green LEDs from 0 to full.
13	Blue1-3	0 - 255	0 - 100%	0	8 bit control of Blue LEDs from 0 to full.
14	White1-3	0 - 255	0 - 100%	0	8 bit control of White LEDs from 0 to full.

4. RGBW 8-bit Group Mode

Table 5 provides DMX channel mapping of all DMX512 control values when the SL BEAM 100 LED Luminaire is in RGBW 8-bit Group mode (as set by the luminaire's menu system).

Table 5: SL BEAM 100 LED Luminaire DMX Channel Mapping (RGBW 8-bit Group Mode)

RGBW 8 BIT MODE		
DMX CHANNEL	3 Group MODE	1 Group MODE
1	Pan	Pan
2	Tilt	Tilt
3	Master Intensity	Master Intensity
4	Color Presets	Color Presets
5	Strobe	Strobe
6	Duration	Duration
7	Zoom	Zoom
8	Focus Timing	Focus Timing
9	Timing	Timing
10	Control	Control
11	Red_1	Red_1-3
12	Green_1	Green_1-3
13	Blue_1	Blue_1-3
14	White_1	White_1-3
15	Red_2	
16	Green_2	
17	Blue	
18	White_2	
19	Red_3	
20	Green_3	
21	Blue_3	
22	White_3	

5. RGBW 16-bit Mode

Table 6 provides DMX channel mapping of all DMX512 control values when the SL BEAM 100 LED Luminaire is in RGBW 16-bit mode (as set by the luminaire's menu system).

Table 6: SL BEAM 100 LED Luminaire DMX Channel Mapping (RGBW 16-bit Mode)

DMX	Parameter	Range DMX	Range %	Defaults	Description
1 2	Pan - High Byte Pan - Low Byte	0 - 65535	0 - 100%	32768	16-bit control of Pan
3 4	Tilt - High Byte Tilt - Low Byte	0 - 65535	0 - 100%	32768	16-bit control of Tilt
5 6	Master Intensity - High Master Intensity - Low	0 - 65535	0 - 100%	0	16 bit control for Intensity of LED settings.
7	Color Presets	0 - 255	0 - 100%	0	Variable color Presets as follows . . . Channel OFF (disabled) DMX 0 - 4 Preset 0 (OFF) DMX 5 - 6 Preset 1 DMX 7 - 8 Preset 2 DMX 9 - 10 Preset 3 DMX 11 - 12 Preset 4 DMX 13 - 14 Preset 5 DMX 15 - 16 Preset 6 DMX 17 - 18

Table 6: SL BEAM 100 LED Luminaire DMX Channel Mapping (RGBW 16-bit Mode)

				Preset 7	DMX 19 - 20
				Preset 8	DMX 21 - 22
				Preset 9	DMX 23 - 24
				Preset 10	DMX 25 - 26
				Preset 11	DMX 27 - 28
				Preset 12	DMX 29 - 30
				Preset 13	DMX 31 - 32
				Preset 14	DMX 33 - 34
				Preset 15	DMX 35 - 36
				Preset 16	DMX 37 - 38
				Preset 17	DMX 39 - 40
				Preset 18	DMX 41 - 42
				Preset 19	DMX 43 - 44
				Preset 20	DMX 45 - 46
				Preset 21	DMX 47 - 48
				Preset 22	DMX 49 - 50
				Preset 23	DMX 51 - 52
				Preset 24	DMX 53 - 54
				Preset 25	DMX 55 - 56
				Preset 26	DMX 57 - 58
				Preset 27	DMX 59 - 60
				Preset 28	DMX 61 - 62
				Preset 29	DMX 63 - 64
				Preset 30	DMX 65 - 66
				Preset 31	DMX 67 - 68
				CF_0_Color OFF	DMX 69 - 70
				CF_1_White 10000K	DMX 71 - 72
7	Color Presets		0	CF_2_White 8000K	DMX 73 - 74
				CF_3_White 6500K	DMX 75 - 76
				CF_4_White 5600K	DMX 77 - 78
				CF_5_White 5000K	DMX 79 - 80
				CF_6_White 4500K	DMX 81 - 82
				CF_7_White 4000K	DMX 83 - 84
				CF_8_White 3200K	DMX 85 - 86
				CF_9_White 3000K	DMX 87 - 88
				CF_10_White 2700K	DMX 89 - 90
				CF_11_Moroccan Pink	DMX 91 - 92
				CF_12_Pink	DMX 93 - 94
				CF_13_Flesh Pink	DMX 95 - 96
				CF_14_Bright Rose	DMX 97 - 98
				CF_15_Follies Pink	DMX 99 - 100
				CF_16_Fuchsia Pink	DMX 101 - 102
				CF_17_Surprise Pink	DMX 103 - 104
				CF_18_Congo Blue	DMX 105 - 106
				CF_19_Blue	DMX 107 - 108
				CF_20_Virgin Blue	DMX 109 - 110
				CF_21_Midnight Maya	DMX 111 - 112
				CF_22_Dluble C.T Blue	DMX 113 - 114
				CF_23_Slate Blue	DMX 115 - 116
				CF_24_Regal Blue	DMX 117 - 118
				CF_25_Fullt C.T Blue	DMX 119 - 120
				CF_26_Steel Blue	DMX 121 - 122
				CF_27_Lighter Blue	DMX 123 - 124
				CF_28_Cyan	DMX 125 - 126
				CF_29_Marine Blue	DMX 127 - 128
				CF_30_Soft Green	DMX 129 - 130
				CF_31_Moss Green	DMX 131 - 132
				CF_32_Green	DMX 133 - 134

Table 6: SL BEAM 100 LED Luminaire DMX Channel Mapping (RGBW 16-bit Mode)

7	Color Presets	0 - 255	0 - 100%	0	CF_33_Fem Green DMX 135 - 136 CF_34_JAS Green DMX 137 - 138 CF_35_Pale Green DMX 139 - 140 CF_36_Spring Yellow DMX 141 - 142 CF_37_Yellow DMX 143 - 144 CF_38_Deep Amber DMX 145 - 146 CF_39_Chrome Orange DMX 147 - 148 CF_40_Orange DMX 149 - 150 CF_41_Magenta DMX 151 - 152 CF_42_Flame Red DMX 153 - 154 CF_43_Purple DMX 155 - 156 Rotate CW Fast→Slow DMX 157 - 171 Rotate ACW Slow→Fast DMX 172 - 186 Random Color Fast→Slow DMX 187 - 201 Chase1 DMX 202 - 204 Chase2 DMX 205 - 207 Chase3 DMX 208 - 210 Chase4 DMX 211 - 213 Chase5 DMX 214 - 216 Chase6 DMX 217 - 219 Chase7 DMX 220 - 222 Chase8 DMX 223 - 225 Chase9 DMX 226 - 228 Chase10 DMX 229 - 231 User Chase1 DMX 232 - 234 User Chase2 DMX 235 - 237 User Chase3 DMX 238 - 240 User Chase4 DMX 241 - 243 User Chase5 DMX 244 - 246 User Chase6 DMX 247 - 249 User Chase7 DMX 250 - 252 User Chase8 DMX 253 - 255
8	Strobe	0 - 255	0 - 100%	0	Controls strobe operations as follows . . . Open DMX 0 - 2 Closed DMX 3 - 5 Slow Rand DMX 6 - 7 Med Rand DMX 8 - 10 Fast Rand DMX 11 - 12 Strobe Range DMX 13 - 127 (fastest) Pulse + Slow Rand DMX 128 - 129 Pulse + Med Rand DMX 130 - 131 Pulse + Fast Rand DMX 132 - 133 Pulse + Range DMX 134 - 191 Pulse - Slow Rand DMX 192 - 193 Pulse - Med Rand DMX 194 - 195 Pulse - Fast Rand DMX 196 - 197 Pulse - Range DMX 198 - 255
9	Duration	0 - 255	0 - 100%	0	Strobe's duration,Range is 0-85 0 DMX 0 1 DMX 1 - 3 x (DMX Value-1)/3+1 85 DMX 253-255

Table 6: SL BEAM 100 LED Luminaire DMX Channel Mapping (RGBW 16-bit Mode)

10	Zoom	0 - 255	0 - 100%	0	Variable control of zoom from 12° - 45°
11	Focus Timing	0 - 255	0 - 100%	255	Timing control of Pan/Tilt
12	Intensity Timing	0 - 255	0 - 100%	255	Allows for timing control of intensity, color, and zoom parameters. Channel should default to 255 for smoothest actions using console and/or manual fades. - See Timing Chart for more details.
13	Color Timing	0 - 255	0 - 100%	255	Allows for timing control of colors. Channel should default to 255 for smoothest actions using console and/or manual fades. - See Timing chart for more details
14	Zoom Timing	0 - 255	0 - 100%	255	Allows for timing control of zoom.
15	Control	0 - 255	0 - 100%	0	<p>Functions of the SL Series products. Set control channel value to desired action, Hold value for at least 5 seconds, then turn to 0. Set control channel value to 0 without any scaling.</p> <p>Default Setting on Console = DMX 0-4 DIM Response_Normal = DMX 5 - 9 DIM Response_Incandescent = DMX 10 - 14 Dimming Curve_linear = DMX 30 - 34 Dimming Curve_Square = DMX 35- 39 Dimming Curve_S-Curve = DMX 40 - 44 Dimming Curve_PL-Curve = DMX 45 - 49 Calibration_OFF = DMX 70 - 74 Calibration_ON = DMX 75 - 79 Fan_Auto = DMX 80 - 84 Fan_Off = DMX 85 - 89 Reserves(Future use) = DMX 90 - 250</p>
16	Red1-3 - High Byte	0 - 65535	0 - 100%	0	16 bit control of Red LEDs from 0 to full.
17	Red1-3 - Low Byte				
18	Green1-3 - High Byte	0 - 65535	0 - 100%	0	16 bit control of Green LEDs from 0 to full.
19	Green1-3 - Low Byte				
20	Blue1-3 - High Byte	0 - 65535	0 - 100%	0	16 bit control of Blue LEDs from 0 to full.
21	Blue1-3 - Low Byte				
22	White1-3 - High Byte	0 - 65535	0 - 100%	0	16 bit control of White LEDs from 0 to full.
23	White1-3 - Low Byte				

6. RGBW 16-bit Group Mode

Table 7 provides DMX channel mapping of all DMX512 control values when the SL BEAM 100 LED Luminaire is in RGBW 16-bit Group mode (as set by the luminaire's menu system).

Table 7: SL BEAM 100 LED Luminaire DMX Channel Mapping (RGBW 16-bit Group Mode)

RGBW 16 BIT MODE		
DMX CHANNEL	3 Group MODE	1 Group MODE
1	Pan - High Byte	Pan - High Byte
2	Pan - Low Byte	Pan - Low Byte
3	Tilt - High Byte	Tilt - High Byte
4	Tilt - Low Byte	Tilt - Low Byte
5	Master Intensity - High	Master Intensity - High
6	Master Intensity - Low	Master Intensity - Low
7	Color Presets	Color Presets
8	Strobe	Strobe
9	Duration	Duration
10	Zoom	Zoom
11	Focus Timing	Focus Timing
12	Intensity Timing	Intensity Timing
13	Color Timing	Color Timing
14	Zoom Timing	Zoom Timing
15	Control	Control
16	Red_1 - High Byte	Red_1-3 - High Byte
17	Red_1 - Low Byte	Red_1-3 - Low Byte
18	Green_1 - High Byte	Green_1-3 - High Byte
19	Green_1 - Low Byte	Green_1-3 - Low Byte
20	Blue_1 - High Byte	Blue_1-3 - High Byte
21	Blue_1 - Low Byte	Blue_1-3 - Low Byte
22	White_1 - High Byte	White_1-3 - High Byte
23	White_1 - Low Byte	White_1-3 - Low Byte
24	Red_2 - High Byte	
25	Red_2 - Low Byte	
26	Green_2 - High Byte	
27	Green_2 - Low Byte	
28	Blue_2 - High Byte	
29	Blue_2 - Low Byte	
30	White_2 - High Byte	
31	White_2 - Low Byte	
32	Red_3 - High Byte	
33	Red_3 - Low Byte	
34	Green_3 - High Byte	
35	Green_3 - Low Byte	
36	Blue_3 - High Byte	
37	Blue_3 - Low Byte	
38	White_3 - High Byte	
39	White_3 - Low Byte	

7. HSIC Mode

Table 8 provides DMX channel mapping of all DMX512 control values when the SL BEAM 100 LED Luminaire is in HSIC mode (as set by the luminaire's menu system).

Table 8: SL BEAM 100 LED Luminaire DMX Channel Mapping (HSIC Mode)

DMX	Parameter	Range DMX	Range %	Defaults	Description
1 2	Pan - High Byte Pan - Low Byte	0 - 65535	0 - 100%	32768	16-bit control of Pan
3 4	Tilt - High Byte Tilt - High Byte	0 - 65535	0 - 100%	32768	16-bit control of Tilt
5	Master Intensity	0 - 255	0 - 100%	0	8 bit control for Intensity of LED settings.
6	Strobe	0 - 255	0 - 100%	0	Controls strobe operations as follows . . . Open = DMX 0 - 2 Closed = DMX 3 - 5 Slow Rand = DMX 6 - 7 Med Rand = DMX 8 - 10 Fast Rand = DMX 11 - 12 Strobe Range = DMX 13 - 127 (fastest) Pulse + Slow Rand = DMX 128 - 129 Pulse + Med Rand = DMX 130 - 131 Pulse + Fast Rand = DMX 132 - 133 Pulse + Range = DMX 134 - 191 Pulse - Slow Rand = DMX 192 - 193 Pulse - Med Rand = DMX 194 - 195 Pulse - Fast Rand = DMX 196 - 197 Pulse - Range = DMX 198 - 255
7	Duration	0 - 255	0 - 100%	0	Strobe's duration, Range is 0-85 0 = DMX 0 1 = DMX 1 - 3 x = (DMX Value-1)/3+1 85 = DMX 253-255
8	Zoom	0 - 255	0 - 100%	0	Variable control of zoom from 12°- 45°.
9	Focus Timing	0 - 255	0 - 100%	255	Timing control of Pan/Tilt
10	Timing	0 - 255	0 - 100%	255	Allows for timing control of intensity, color, and zoom parameters. Channel should default to 255 for smoothest actions using console and/or manual fades. - See Timing Chart for more details.
11	Control	0 - 255	0 - 100%	0	Functions of the SL Series products. Set control channel value to desired action. Hold value for at least 5 seconds, then turn to 0. Set control channel value to 0 without any scaling. Default Setting on Console = DMX 0-4 DIM Response_Normal = DMX 5 - 9 DIM Response_Incandescent = DMX 10 - 14 Dimming Curve_linear = DMX 30 - 34 Dimming Curve_Square = DMX 35- 39 Dimming Curve_S-Curve = DMX 40 - 44 Dimming Curve_PL-Curve = DMX 45 - 49 Calibration_OFF = DMX 70 - 74 Calibration_ON = DMX 75 - 79 Fan_Auto = DMX 80 - 84 Fan_Off = DMX 85 - 89 Reserves(Future use) = DMX 90 - 250
12 13	Hue1-3 - High Byte Hue1-3 - Low Byte	0 - 65535	0 - 100%	0	16 bit control of Hue 0 - 359°
14	Saturation1-3	0 - 255	0 - 100%	0	8 bit control of Saturation.
15	Intensity1-3	0 - 255	0 - 100%	0	8 bit control of Intensity.
16	CCT1-3	0 - 255	0 - 100%	0	Variable control of correlated color temperature from Channel OFF (disabled) DMX 0 - 5 2700K - 6500K. DMX 6 - 255

8. HSIC Group Mode

Table 9 provides DMX channel mapping of all DMX512 control values when the SL BEAM 100 LED Luminaire is in HSIC Group mode (as set by the luminaire's menu system).

Table 9: SL BEAM 100 LED Luminaire DMX Channel Mapping (HSIC Group Mode)

DMX CHANNEL	HSIC MODE	
	3 Group MODE	1 Group MODE
1	Pan - High Byte	Pan - High Byte
2	Pan - Low Byte	Pan - Low Byte
3	Tilt - High Byte	Tilt - High Byte
4	Tilt - Low Byte	Tilt - Low Byte
5	Master Intensity	Master Intensity
6	Strobe	Strobe
7	Duration	Duration
8	Zoom	Zoom
9	Focus Timing	Focus Timing
10	Timing	Timing
11	Control	Control
12	Hue_1 - High Byte	Hue_1-3 - High Byte
13	Hue_1 - Low Byte	Hue_1-3 - Low Byte
14	Saturation_1	Saturation_1-3
15	Intensity_1	Intensity_1-3
16	CCT_1	CCT_1-3
17	Hue_2 - High Byte	
18	Hue_2 - Low Byte	
19	Saturation_2	
20	Intensity_2	
21	CCT_2	
22	Hue_3 - High Byte	
23	Hue_3 - Low Byte	
24	Saturation_3	
25	Intensity_3	
26	CCT_3	

9. SL BEAM100 LED Luminaire DMX Timing Channel Detail

Timing channel control improves the timed moves of certain groups of parameters. The SL BEAM 100 LED Luminaire provides timing channels in 16-bit mode (one for intensity time and one for color time) and one timing channel in 8-bit (color and intensity timing combined). The luminaire uses its timing channel value to calculate a smooth continuous operation for a given time and transition.

Guidelines:

- Timing channels support time values from zero to 60 minutes.
- To use a timing channel instead of console timing, it is recommended to set the timing channel to the desired value and set cue and/or console cue fade time to zero. A combination of time controls can produce unexpected results.
- The default value setting in the profile should be 255 (proportional control) to allow smooth operation when using console timing.
- The timing channel data should change as a snap. A zero value will give the fastest operation, however, without any smoothing this can appear "steppy" in console timed moves.

Refer to "[SL BEAM 100 LED Luminaire DMX Timing Channel Detail](#)" for more information.

Table 10: SL BEAM 100 LED Luminaire Timing Channel Detail

% Value	DMX	= Seconds (unless noted)
0	0	0 (Full Speed)
	1	0.2
	2	0.4
1	3	0.6
	4	0.8
2	5	1
	6	1.2
	7	1.4
3	8	1.6
	9	1.8
4	10	2
	11	2.2
	12	2.4
5	13	2.6
	14	2.8
6	15	3
	16	3.2
	17	3.4
7	18	3.6
	19	3.8
8	20	4
	21	4.2
	22	4.4
9	23	4.6
	24	4.8
10	25	5
	26	5.2
	27	5.4
11	28	5.6
	29	5.8
	30	6
12	31	6.2

Table 10: SL BEAM 100 LED Luminaire Timing Channel Detail

% Value	DMX	= Seconds (unless noted)
	32	6.4
13	33	6.6
	34	6.8
	35	7.0
14	36	7.2
	37	7.4
15	38	7.6
	39	7.8
	40	8
16	41	8.2
	42	8.4
17	43	8.6
	44	8.8
	45	9
18	46	9.2
	47	9.4
19	48	9.6
	49	9.8
	50	10
20	51	10.2
	52	10.4
	53	10.6
21	54	10.8
	55	11
22	56	11.2
	57	11.4
	58	11.6
23	59	11.8
	60	12
24	61	12.2
	62	12.4
	63	12.6
25	64	12.8
	65	13
26	66	13.2
	67	13.4
	68	13.6
27	69	13.8
	70	14
28	71	14.2
	72	14.4
	73	14.6
29	74	14.8
	75	15
30	76	15.2
	77	15.4
	78	15.6
31	79	15.8
	80	16
	81	16.2
32	82	16.4

Table 10: SL BEAM 100 LED Luminaire Timing Channel Detail

% Value	DMX	= Seconds (unless noted)
	83	16.6
33	84	16.8
	85	17
	86	17.2
34	87	17.4
	88	17.6
35	89	17.8
	90	18
	91	18.2
36	92	18.4
	93	18.6
37	94	18.8
	95	19
	96	19.2
38	97	19.4
	98	19.6
39	99	19.8
	100	20
	101	21
40	102	22
	103	23
	104	24
41	105	25
	106	26
42	107	27
	108	28
	109	29
43	110	30
	111	31
44	112	32
	113	33
	114	34
45	115	35
	116	36
46	117	37
	118	38
	119	39
47	120	40
	121	41
48	122	42
	123	43
	124	44
49	125	45
	126	46
	127	47
50	128	48
	129	49
51	130	50
	131	51
	132	52
52	133	53

Table 10: SL BEAM 100 LED Luminaire Timing Channel Detail

% Value	DMX	= Seconds (unless noted)
	134	54
53	135	55
	136	56
	137	57
54	138	58
	139	59
55	140	60
	141	61
	142	62
56	143	63
	144	64
57	145	65
	146	66
	147	67
58	148	68
	149	69
59	150	70
	151	71
	152	72
60	153	73
	154	74
	155	75
61	156	76
	157	77
62	158	78
	159	79
	160	80
63	161	81
	162	82
64	163	83
	164	84
	165	85
65	166	86
	167	87
66	168	88
	169	89
	170	90
67	171	91
	172	92
68	173	93
	174	94
	175	95
69	176	96
	177	97
	178	98
70	179	99
	180	100
71	181	101
	182	102
	183	103
72	184	104

Table 10: SL BEAM 100 LED Luminaire Timing Channel Detail

% Value	DMX	= Seconds (unless noted)
	185	105
73	186	106
	187	107
	188	108
74	189	109
	190	110
75	191	111
	192	112
	193	113
76	194	114
	195	115
77	196	116
	197	117
	198	118
78	199	119
	200	120
79	201	121
	202	122
	203	123
80	204	124
	205	125
81	206	126
	207	127
	208	128
82	209	129
	210	130
	211	131
83	212	132
	213	133
84	214	134
	215	135
	216	136
85	217	137
	218	138
86	219	139
	220	140
	221	141
87	222	142
	223	143
88	224	144
	225	145
	226	146
89	227	147
	228	148
	229	149
90	230	150
	231	151
91	232	152
	233	153
	234	154
92	235	155

Table 10: SL BEAM 100 LED Luminaire Timing Channel Detail

% Value	DMX	= Seconds <i>(unless noted)</i>
	236	156
93	237	157
	238	158
	239	159
94	240	160
	241	161
95	242	162
	243	163
	244	164
96	245	165
	246	5 Minutes
97	247	15 Minutes
	248	30 Minutes
	249	60 Minutes
98	250*	60ms
	251*	80ms
99	252*	100ms
	253*	100ms
	254*	140ms
100	255* (default)	160ms

Note: * DMX values 250 to 255 provide smoothing when using console fade timing. DMX value 255 (recommended default) will provide the smoothest timing.

10. SL BEAM 100 LED Luminaire RDM Parameter IDs

The following tables outline and describe all the RDM parameters IDs associated with SL BEAM 100 LED Luminaires.

Table 11, "SL BEAM 100 LED Luminaire RDM Product Parameters IDs"

Table 12, "SL BEAM 100 CW LED Luminaire RDM UID"

Table 13, "SL BEAM 100 LED Luminaire RDM Parameters IDs,"on page 33

Table 14, "SL BEAM 100 LED Luminaire RDM Manufacturer Status IDs,"on page 34

Table 15, "SL BEAM 100 LED Luminaire RDM Manufacturer Specific PIDs for Root Device,"on page35

Table 16, "SL BEAM 100 LED Luminaire RDM Manufacturer Specific PIDs for Sub Device on page 35

Table 11: SL BEAM 100 LED Luminaire RDM Product Parameters IDs

Model ID	Manufacturer	Model Description	Product Category
0x11B0	Philips Entertain. Lighting Asia	SL BEAM 100(RGBW)	0x0509

Table 12: SL BEAM 100 LED Luminaire RDM UID

UID					
MSB of ESTA 50H	LSB of ESTA 41H	1st of Unique Seq.	2nd of Unique Seq.	3rd of Unique Seq.	4th of Unique Seq.

Table 13: SL BEAM 100 LED Luminaire RDM Parameters IDs

Get Allowed	Set Allowed	RDM Parameter IDs	Value	Comment	Implemented
Category - Network Management					
		DISC_UNIQUE_BRANCH	0x0001		■
		DISC_MUTE	0x0002		■
		DISC_UN_MUTE	0x0003		■
■		PROXIED_DEVICES	0x0010		
■		PROXIED_DEVICES_COUNT	0x0011		
■	■	COMMS_STATUS	0x0015		
Category - Status Collection					
■		QUEUED_MESSAGE	0x0020		■
■		STATUS_MESSAGES	0x0030		■
■		STATUS_ID_DESCRIPTION	0x0031		■
	■	CLEAR_STATUS_ID	0x0032		■
■	■	SUB_DEVICE_STATUS_REPORT_THRESHOLD	0x0033		
Category - RDM Information					
■		SUPPORTED_PARAMETERS	0x0050	Support required only if supporting Parameters beyond the minimum required set.	■
■		PARAMETER_DESCRIPTION	0x0051	Support required for Manufacturer-Specific PIDs exposed in SUPPORTED_PARAMETERS message.	■
Category - Product Information					
■		DEVICE_INFO	0x0060		■
■		PRODUCT_DETAIL_ID_LIST	0x0070		
■		DEVICE_MODEL_DESCRIPTION	0x0080		■
■		MANUFACTURER_LABEL	0x0081		■
■	■	DEVICE_LABEL	0x0082		■
■	■	FACTORY_DEFAULTS	0x0090		■
■		LANGUAGE_CAPABILITIES	0x00A0		
■	■	LANGUAGE	0x00B0		
■		SOFTWARE_VERSION_LABEL	0x00C0		■
■		BOOT_SOFTWARE_VERSION_ID	0x00C1		
■		BOOT_SOFTWARE_VERSION_LABEL	0x00C2		
Category - DMX512 Setup					
■	■	DMX_PERSONALITY	0x00E0		■
■		DMX_PERSONALITY_DESCRIPTION	0x00E1		■
■	■	DMX_START_ADDRESS	0x00F0	Required if device uses a DMX Slot	■
■		SLOT_INFO	0x0120		■
■		SLOT_DESCRIPTION	0x0121		■
■		DEFAULT_SLOT_VALUE	0x0122		
Category - Sensors 0x02xx					
■		SENSOR_DEFINITION	0x0200		■
■	■	SENSOR_VALUE	0x0201		■

Table 13: SL BEAM 100 LED Luminaire RDM Parameters IDs

Get Allowed	Set Allowed	RDM Parameter IDs	Value	Comment	Implemented
	■	RECORD_SENSORS	0x0202		
<i>Category - Dimmer Settings 0x03xx - FUTURE USE</i>					
<i>Category - Power / Lamp Settings 0x04xx</i>					
■	■	DEVICE_HOURS	0x0400		
■	■	LAMP_HOURS	0x0401		
■	■	LAMP_STRIKES	0x0402		
■	■	LAMP_STATE	0x0403		
■	■	LAMP_ON_MODE	0x0404		
■	■	DEVICE_POWER_CYCLES	0x0405		
<i>Category - Display Settings 0x05xx</i>					
■	■	DISPLAY_INVERT	0x0500		■
■	■	DISPLAY_LEVEL	0x0501		
<i>Category - Configuration 0x06xx</i>					
■	■	PAN_INVERT	0x0600		
■	■	TILT_INVERT	0x0601		
■	■	PAN_TILT_SWAP	0x0602		
■	■	REAL_TIME_CLOCK	0x0603		
<i>Category - Control 0x10xx</i>					
■	■	IDENTIFY_DEVICE	0x1000		■
	■	RESET_DEVICE	0x1001		
■	■	POWER_STATE	0x1010		
■	■	PERFORM_SELFTEST	0x1020		
■		SELF_TEST_DESCRIPTION	0x1021		
	■	CAPTURE_PRESET	0x1030		
■	■	PRESET_PLAYBACK	0x1031		

Table 14: SL BEAM 100 LED Luminaire RDM Manufacturer Status IDs

Manufacturer Specific messages are in the range of 0x8000 - 0xFFDF. Each Manufacturer-specific Status ID shall have a unique meaning, which shall be consistent across all products having a given Manufacturer ID. See Table B-2, ANSI E1.20-2010.

Status ID Message	Value	Data Value 1	Data Value 2	Status ID Description
8100H		00H	00H	ALL OK

Table 15: SL BEAM 100 LED Luminaire RDM Manufacturer Specific PIDs for Root Device

Get Allowed	Set Allowed	RDM Parameter IDs	Type	Length	Unit	Prefix	Min	Max	Default	Description
<i>Category - Manufacturer Defined PIDs - Range is 0x8000-0xffff (See ANSI E1.20-2010 Standard, Table A-3)</i>										
■	■	8A00H	U8	1	None	None	0	100	100	DIMMER
■	■	8AB2H	U8	1	None	None	1	18	1	Chase
■	■	8AB0H	U8	1	None	None	0	43	0	Color Filter
■	■	8AB1H	U8	1	None	None	0	31	0	Preset
■	■	8A92H	U8	1	None	None	0	255	0	Strobe
■	■	8A94H	U8	1	None	None	0	255	0	Duration
■	■	8A95H	U16	1	None	None	0	65535	0	Pan
■	■	8A96H	U16	1	None	None	0	65535	0	Tilt
■	■	8A97H	U8	1	None	None	0	1	0	Fan AUTO/OFF Setup
■	■	8AC3H	U8	1	None	None	0	255	0	Pan/Tilt Timing
■	■	8AC0H	U8	1	None	None	0	255	255	Intensity Timing
■	■	8AC1H	U8	1	None	None	0	255	255	Beam Timing
■	■	8AC2H	U8	1	None	None	0	255	255	Color Timing
■	■	8A40H	U8	1	None	None	0	1	0	Link Mode
■	■	8A42H	U8	1	None	None	0	1	0	Incandescent Effect
■	■	8AA1H	U8	1	None	None	0	3	0	Dimming Curve
■	■	8A0CH	U8	1	None	None	0	3	0	DMX Fail Mode
■	■	8AA0H	U8	1	None	None	0	4	0	Backlight Off Time
■	■	8AA2H	U8	1	None	None	0	94	0	Power UP Setup
■	■	8A44H	U8	1	None	None	0	1	0	Calibration ON/OFF setup
■	■	8A41H	U8	1	None	None	0	1	0	Lock Fixture

Table 16: SL BEAM 100 LED Luminaire RDM Manufacturer Specific PIDs for Sub Device

Get Allowed	Set Allowed	RDM Parameter IDs	Type	Length	Unit	Prefix	Min	Max	Default	Description
<i>Category - Manufacturer Defined PIDs - Range is 0x8000-0xffff (See ANSI E1.20-2010 Standard, Table A-3)</i>										
■	■	8A04H	U8	1	None	None	0	100	100	Dimmer RED
■	■	8A05H	U8	1	None	None	0	100	100	Dimmer GREEN
■	■	8A06H	U8	1	None	None	0	100	100	Dimmer BLUE
■	■	8A07H	U8	1	None	None	0	100	100	Dimmer WHITE

CLEANING AND CARE



WARNING! All cleaning should be performed with power completely removed from the luminaire. Never remove protective covers when luminaire is powered. Wear appropriate protective eye wear and gloves when cleaning the fixture. All service and maintenance, other than described herein, should be performed by a qualified technician or Authorized Service Center.

1. Special Cleaning and Care Instructions

Being a solid-state fixture, and unlike most fixtures, the SL BEAM 100 LED Luminaire requires very little routine maintenance by the user. This section covers portions of the luminaire that can be removed for cleaning.

The SL BEAM 100 LED Luminaire special care when it comes to cleaning front lens assembly. Additional care needs to be taken with the plastic components because they are much easier to scratch or damage than glass.

The following is a list of cleaning materials required to care for your SL BEAM 100 LED Luminaire:

- Lint free lens tissue
- Lint or powder free gloves
- Reagent grade isopropyl alcohol*
- A mild soap solution.

Note: *Reagent grade isopropyl alcohol is good to use on the SL BEAM 100 LED Luminaire plastic optics with anti-reflection coatings.

If the lens is still dirty after using isopropyl alcohol, for instance if fingerprints or oil is just redistributed and not cleaned off the optic, then a mild soap and water solution can be used to gently wash the lens. Repeat the cleaning with isopropyl alcohol to eliminate streaks and soap residue.



WARNING! Under no circumstances should ammonia-based cleaners, acetone, or other harsh solvents be used on or near the SL BEAM 100 LED Luminaire. These types of cleaners or solvents can permanently damage the optics or housings of the fixture.

If you have any questions regarding the use or care of your SL BEAM 100 LED Luminaire, please contact Showline technical support or your local Authorized Dealer.

2. Front Lens Cleaning

To clean the front lens:

- Step 1. Disconnect luminaire from power and allow to cool completely.
- Step 2. Apply a small amount of reagent grade isopropyl alcohol to lint-free lens tissue.
- Step 3. Wipe all debris, dirt, fingerprints, etc. from lens.
- Step 4. Using a second lint-free lens tissue, wipe off any alcohol residue.

3. Service and Maintenance

For all other service and maintenance issues, please contact your local Showline office or an Authorized Service Center.



WARNING! Disassembly (other than as described herein), alterations, unauthorized service, etc. will void the product warranty. Contact your local Showline office or an Authorized Service Center for technical support and service.

TECHNICAL SPECIFICATIONS

1. SL BEAM 100 LED Luminaire Operational Specifications

Source:	CW LED Array
Beam Angle:	6-45 Degrees
Light Output:	> 1,500 lumens
Color Temperature:	2700 - 6500K (user adjustable)
Input Voltage (AC):	100V to 240V (+/- 10%, auto-ranging)
Current (AC):	1.5 Amps (100V) / 0.62 Amps (240V)
Frequency:	50/60Hz
Control Protocols:	DMX512 (1990) / DMX512A (RDM) / On-Board Menu
Ambient Temperature:	-20 to 40 Degrees C (-4 to 104 Degrees F)
Humidity:	5%-95% Non condensing
Cooling:	Forced Air Cooling
Weight:	16.72 lbs (7.6 kg) - Luminaire only (no accessories)
Housing:	Die Cast Aluminium with Powder Coating
Compliance:	CE Marked (International models)
IP Rating:	Ip20

Note: Common model specifications shown. For specific model specifications, features, and accessories, refer to the product specification sheet for more details.

2. SL BEAM 100 LED Luminaire Dimensions

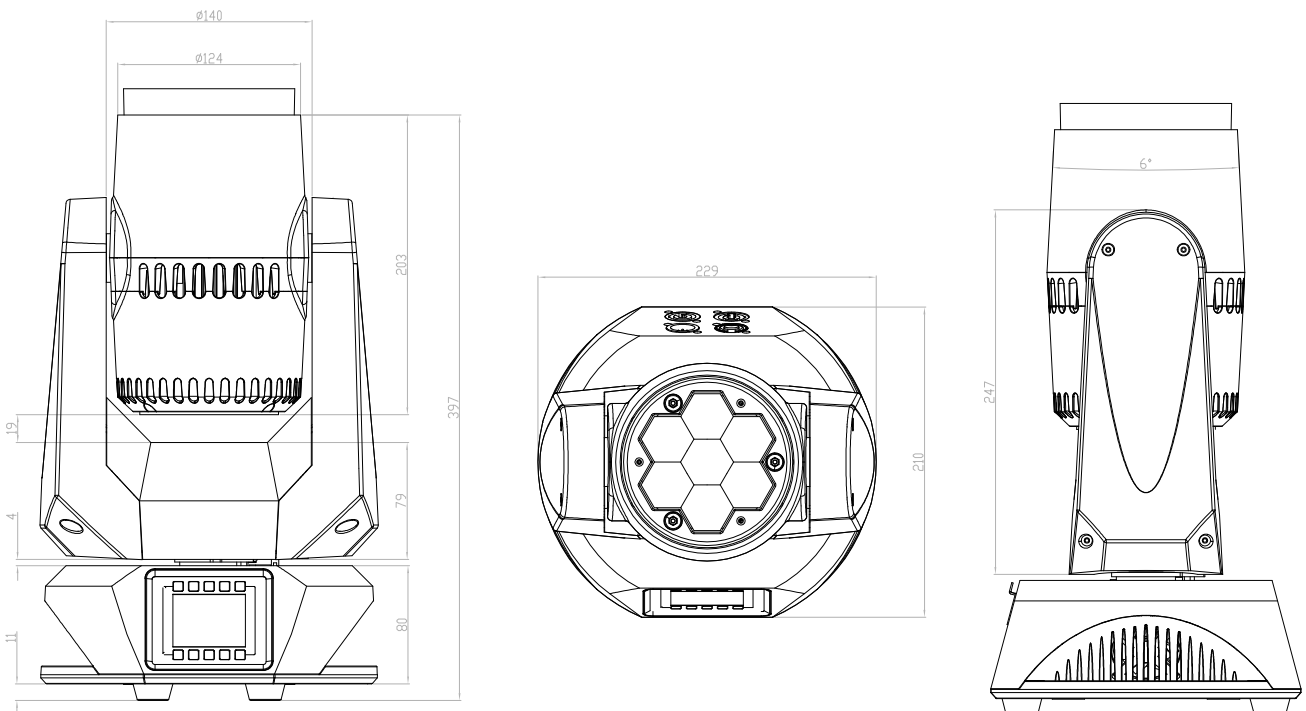

TECHNICAL SUPPORT

GLOBAL 24HR TECHNICAL SUPPORT:

Call: +1 214 647 7880

entertainment.service@signify.com

NORTH AMERICA SUPPORT:

Call: 877-VARI-LITE (877-827-4583)

entertainment.service@signify.com

EUROPEAN CUSTOMER SERVICE CENTER:

Call: +31 (0) 543 542 531

entertainment.europe@signify.com

© 2023 Signify Holding. All rights reserved. All trademarks are owned by Signify Holding or their respective owners. The information provided herein is subject to change, without notice. Signify does not give any representation or warranty as to the accuracy or completeness of the information included herein and shall not be liable for any action in reliance thereon. The information presented in this document is not intended as any commercial offer and does not form part of any quotation or contract, unless otherwise agreed by Signify. Data subject to change.