

VL440 Spot

l u m i n a i r e



The VARI***LITE** VL440 Spot luminaire is compact and economical but still loaded with powerful and useful features. This new series of luminaire from Philips Vari-Lite provides lighting designers with effective and creative tools for any venue or production size.

The VL440 Spot luminaire comes complete with all of the optical quality and functionality designers have come to expect from Philips Vari-Lite. It is small, lightweight, and fast with a 400-watt MSR Gold 400 MiniFastFit lamp, very impressive lumen output, a zoom range from 15° to 36°, and a mechanical iris for continuous beam control. A drop in frost glass assembly allows users to soften the overall beam, allowing for additional beam control. Built in mounting points on the front of the luminaire provide for easy attachment of after-market accessories such as top hats.

The VL440 Spot luminaire provides brilliant color mixing with its three-wheel CYM color assembly. When combined with eight standard colors on a fixed wheel, the color options are practically limitless.

Additionally, a coated glass dimmer wheel provides smooth fades, and a separate dual-blade strobe system offers quiet and reliable strobe effects. The VL440 Spot luminaire's powerful pan and tilt motors provide smooth, fast time-controlled continuous motion capable of 0.3° resolution with a pan range of 540° and tilt of 260°.

For image projection, the fixture has one gobo wheel with seven rotatable and indexable positions and a second gobo wheel with ten fixed positions. The VL440 Spot luminaire comes equipped with glass gobos and effects.

The VL440 Spot luminaire contains everything that really matters to designers – limitless color options, unmatched clarity of optics, exceptional zoom range, fast, smooth movement and powerful output; all of these features are combined in a compact, lightweight and cost-effective, new luminaire.

The VL440 Spot luminaire can be controlled from virtually any DMX512 console or DMX output device. An optional wireless DMX module supports various wireless DMX formats.

Programmable Functions

Intensity Control:
Color Mixing System:

A coated glass dimmer wheel provides full-field dimming designed for smooth timed fades. A three filter CYM cross-fading mechanism plus a fixed color wheel with eight interchangeable color filters and one open space. Fixed wheel is capable of continuous rotation for additional effects.

Zoom Optics / Control:

High-speed, precision zoom optical system with continuously variable field angle from approximately 15° to 36°; programmable over a timed range of 1.5 seconds to 20 minutes.

Strobe:
Beam Size Control:

A high-performance dual blade strobe system capable of ultra-fast operation. In addition to the zoom optics, a mechanical iris provides continuous beam size control for both rapid changes and smooth timed beam angle changes.

Gobo Wheels:

One rotating gobo wheel with seven rotatable, indexable gobo positions and one open position. One fixed gobo wheel with ten easily loaded patterns and one open position capable of continuous rotation for additional effects. 17 total gobo positions. Accepts only glass gobos. Includes all glass standard patterns.

Edge & Pattern Focus:
Frost and Prism Capability:

Variable beam focus to soften edges of gobos or spots. Independent, drop-in armature with frost glass. Second, independent, drop-in armature with rotating and indexable five facet prism. Both the frost and prism pieces are interchangeable.

Pan and Tilt:

Smooth, time-controlled continuous motion by way of a high-power, three-phase stepper motor system capable of 0.3° resolution. Unit has integral pan and tilt transport/service locks. Pan - 540°, Tilt - 260°.

Range:

Description

Source: 400W MSR Gold 400 MiniFastFit Lamp
Color Temp: 6000K **CRI:** > 75 Ra8

Output: 9,000 Lumens
Power Requirements: Standard AC power distribution from 100 - 240VAC, 50/60 Hz. The unit requires up to 6.6A depending on the AC supply voltage.

Reflector: Precision faceted, elliptical glass reflector system with dichroic cold mirror coating.
Operational Temperature: -20° to 122°F (-29° to 50°C)

Cooling: Forced air cooling.

Control: Completely compatible with a wide variety of DMX512 lighting control consoles. Optional wireless DMX accessories for Wireless Solutions, Lumen Radio, and City Theatrical.

DMX Channels: 30 channels.

Mounting Position: May be mounted and operated in any orientation.

Spacing: Hangs on 23 inch (58.5 cm) centers.

Weight: Luminaire - 56.0 lbs (25.5 kg).

Ordering Information

VL440 Spot luminaires:

20.9687.0002
20.9687.0002.02

VL440 Spot Luminaire, Includes 400W Lamp, Black
VL440 Spot Luminaire, Includes 400W Lamp, White

Accessories:

71.9687.0400
22.9620.0194
28.8550.0054
28.9687.0100
28.9687.0101
28.9687.0102
55.6840.0001
55.6841.0001
PC1BE
PC1GP
PC1GTL
PC1GR

400W MSR Gold 400 MiniFastFit Lamp
Safety Cable Assembly
USB Luminaire Programming Kit
Wireless Solutions Wireless DMX Receiver for VL440/VL770/VL880
Lumen Radio Wireless DMX Receiver for VL440/VL770/VL880
City Theatrical Wireless DMX Receiver for VL440/VL770/VL880
Truss Hook, Mega-Clamp, Round and Square
Truss Hook, Mega-Claw for 2" Round Tube
AC Input Cable, PowerCon with Bare End (no connector), 1 Meter
AC Input Cable, PowerCon with Stage Pin (Male), 1 Meter
AC Input Cable, PowerCon with Twist Lock (Male), 1 Meter
AC Input Cable, PowerCon with Edison (Male), 1 Meter



PHILIPS

VARI*LITE****

VL440 Spot

l u m i n a i r e

Specifications

The unit is an integrally designed, remote-controlled, motorized spot luminaire. The head, yoke, and enclosure housings are constructed of aluminum alloy, plastic and steel for lightweight strength and durability. Virtually silent, variable fans shall be used to provide forced-air cooling for internal components.

The rear cap is removable, providing easy access to the lamp for replacement. A single AC input connector along with two, five-pin DMX512 compatible connectors (in and through) are provided. The unit can be controlled by a wide variety of DMX512 consoles. The unit shall include a wireless DMX accessory mounting location and connection.

Each unit is equipped with multiple on-board processors providing diagnostic and self-calibration functions as well as internal test routines and software update capabilities. The unit contains two independent three-phase stepper motors to provide movement of the head through 540° in the horizontal plane (pan) and 260° in the vertical plane (tilt). The pan and tilt mechanisms are belt-driven, providing positional resolution and repeatability of 0.3° on either axis. Unit shall have integral pan and tilt transport/service locks.

The unit shall include a CYM color-mixing system using three wheels which are provided for a broad range of user color selection. In addition to the CYM system, a fixed color wheel with eight interchangeable colors is included for specific color requirements and snap color changes in .14 seconds. The unit comes equipped with a standard palette of dichroic color filters.

The unit shall include a fixed gobo wheel that holds 10 interchangeable gobos. The unit shall include a second gobo wheel containing seven individually rotating indexable gobos. Its operation is achieved by two motors, which provide independent drive regardless of the direction of movement. All seven rotating gobos are easily interchangeable to allow further customization of the unit. The unit shall come equipped with 17 standard glass gobo patterns and effects. A wide selection of gobos are available from Vari-Lite for an additional charge.

The unit contains a coated glass dimmer wheel that provides full field dimming and allows for both smooth timed fades and fast blackouts. A high-performance, dual blade strobe system is operated with two motors and is capable of various strobe effects. A mechanical iris provides continuous beam size control for both rapid changes and smooth timed beam angle changes. Variable beam focus is provided to soften the edges of gobos or spots and to provide gobo morphing. A powerful zoom lens system offers an adjustable field angle from 15° to 36°. When used in combination with the beam size iris, the unit can project a beam with a field angle of 8°.

The unit shall offer frost capability with an independent, drop-in armature that holds frost glass. Additionally, unit shall have a second, independent, drop-in armature that holds a rotating, four facet, indexable prism. Both the frost and prism pieces shall be interchangeable. Unit shall have frontal accessory mounting points for attachment of after-market accessories such as top hats.

The unit is ETL and ETLc certified and CE marked. Exterior finish is black.

Hanging Dimensions

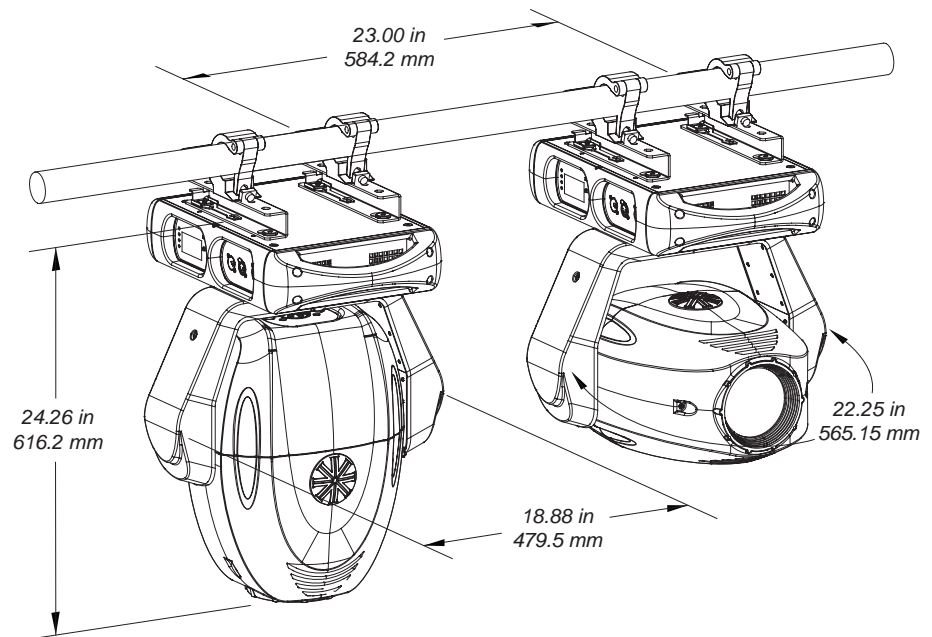

Photometric Data

400W MSR Gold 400 MiniFastFit Lamp		
Field Angle (degrees)	Lumens	Center Beam Candela (cd)
15.0	8,500	275,300
26.0	8,750	93,800
36.0	9,000	51,200

PHILIPS
VARI*LITE

©2013 Philips Group. All rights reserved. Printed in the U.S.A. We reserve the right to change details of design, materials and finishes. Specifications are subject to change without notice. VARI*LITE automated lighting equipment is made in the U.S.A.

Vari-Lite
10911 Petal Street
Dallas, TX 75238
1.877.VARILITE
fax: 214.647.8038
www.vari-lite.com



Intertek



VL440 Spot - 082113NA