

## ACCLAIM FRESNEL AND PC USER MANUAL

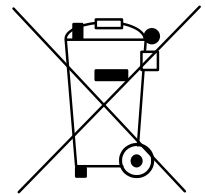

**IMPORTANT NOTE:** Before discarding the packaging ensure you have the suspension bolt set, colour frame, lampbase spacers &/or the lamp.

**THANK YOU FOR PURCHASING A SELECON LUMINAIRE. WE HAVE DESIGNED THIS LUMINAIRE TO PROVIDE YOU WITH A SUPERIOR FITTING IN PERFORMANCE, DESIGN AND ENGINEERING. WE ARE CONFIDENT THAT IT WILL PERFORM TO YOUR EXPECTATIONS FOR MANY YEARS TO COME.**

Before operating your new luminaire please read this information to assist you in making maximum use of your luminaire, its maintenance and care. If you would like further assistance contact your Selecon dealer or Selecon.

### LAMPING YOUR LUMINAIRE

**Before lamping – DISCONNECT THE LUMINAIRE FROM THE POWER SUPPLY. Be aware also that the lamp or luminaire may still be hot, so exercise the necessary caution to avoid burns. Please note also that these luminaires are not suitable for mounting on a normally flammable surface.**

The Selecon Acclaim Fresnel and PC range is designed for use with either the T/25 500W or T/27 650W or the FRK 650W lamp.

To fit the lamp:

- ◆ Release the clip fastener and swing down the rear door.
- ◆ Insert lamp taking care not to touch the quartz envelope with your fingers.
- ◆ Close door and lock off the fastener.

□ 1.5m / 5ft □

**The luminaire should be at least 1.5m / 5ft away from the nearest object it is lighting.**

## **MOUNTING YOUR LUMINAIRE**

Your luminaire uses a theatre lamp with a grid filament. To avoid premature lamp failure it is essential that the luminaire is always mounted so the yoke is horizontal and with the lamp base down, i.e. the lamp adjustment knob is at the bottom of the rear lamp plate.

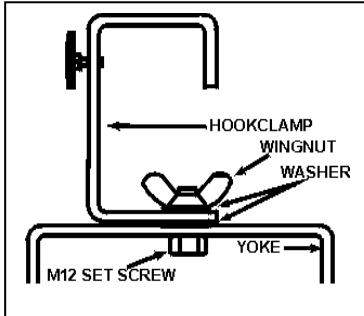

To mount on the theatre standard scaffold pipe (48mm O.D.) use a theatre hook clamp (G clamp) (Order Code: 20HC). Your luminaire is supplied with a 12mm set screw, washers and a nut. Thread the set screw through the yoke from the inside, put on a washer, then the hook clamp, another washer and then do up finger tight with the nut.

To mount on a telescopic stand, reverse the yoke under the luminaire and bolt the stand's spigot onto the 10mm set screw.

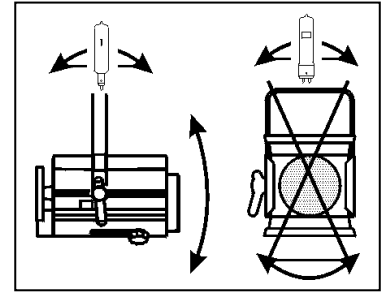

## **SAFETY CHAIN**

A safety chain **MUST** always be used when rigging luminaires on bars, ladders etc. The Acclaim Fresnel and PC have an integral safety chain that can be retracted into the luminaire when not in use. To use the safety chain, unscrew the safety chain locking clamp located on the top of the lamphouse, pull the clip out from the rear of the lamphouse, and loop the safety chain around the bar fastening the clip onto the safety chain. Be careful to allow sufficient slack to enable the luminaire to be focused freely. To replace the safety chain, remove the rear lamphouse moulding, slide out the safety chain locking clamp, and pull out the safety chain, taking care to retain the safety chain loop bar. Reverse the process with a new safety chain. Replace only with the approved safety chains available from Selecon or your distributor.

## **FOCUSING**

The variable beam of the Acclaim Fresnel or PC is altered by adjusting the position of the lamp / reflector assembly relative to the lens. Finger tight pressure only is necessary to lock the lamp / reflector assembly off in the chosen positions. A beam angle reference scale is provided to pre-focus the luminaire if desired.

When focusing, first spot the beam down, position the luminaire and then flood the beam to cover the area required. The beam can then be shaped using the four-flap barndoor accessory (Order Code: 20BDMF).

## **YOKE PIVOT ADJUSTMENT**

The yoke on the Acclaim range can be positioned anywhere in the channel that runs the length of the luminaire. This is useful to achieve the best balance if using a colour changer or other accessory mounted on the front of the luminaire, or to fit the luminaire in space restricted positions.

The yoke balance point is factory set on the lamp house for normal applications. To move the yoke, loosen the M8 bolt at the bottom pivot point of the yoke on the right side of the luminaire. Release the tilt locking clamp on the left side of the luminaire, and slide the yoke to the required position. Check the yoke is evenly positioned on each side and tighten the M8 bolt, and the tilt locking clamp. To return the yoke to its original balance point, align the yoke to the balance point marked on the focus reference scale.

## **PAN AND TILT ADJUSTMENT**

To pan your luminaire loosen the yoke nut and bolt holding the hook clamp onto the yoke and adjust the yoke as required, then retighten the yoke nut and bolt.

The nylock nut that secures the yoke on the opposite side to the tilt handle sets the tilt lock friction. The tilt friction can be adjusted by loosening or tightening up the nylock nut. To tilt your luminaire, turn the tilt lock knob clockwise, tilt the luminaire to the position required, and then turn the tilt lock knob anticlockwise. A tilt angle reference scale is provided on the locking clamp disc to pre-focus the luminaire if desired.

Please note that as the handles on the Acclaim range can reach high temperatures depending on the position or orientation of the luminaire, and that gloves should always be worn when focusing these luminaires.

## ACCESSORIES

- ◆ Suspension hook clamp (Order Code: 20HC)
- ◆ Lens safety mesh (Order Code: 15ACSM)
- ◆ Colour frame – the luminaire is supplied with a 186mm x 190mm colour frame. Additional colour frames are available (Order Code: 20CCFMF).
- ◆ Barndoor (Order Code: 20BDMF)
- ◆ Safety chain wire (Order Code: RASWFR)

## EARTH TEST POINT

There is an earth test point located on the rear housing of the Acclaim Fresnel or PC luminaire. The earth test point is the silver machine screw located on the right side of the rear housing, and is indicated by an earth symbol. To test the earth of your Acclaim, place the test probe on the silver machine screw, and perform the earth test.

## CLEANING

Open the down-swinging door, and clean the lens and/or reflector with a soft lint-free cloth.

**This is the only maintenance task, which can be safely carried out by non-approved personnel. Refer below – Safety & Maintenance note.**

## SAFETY & MAINTENANCE

Selecon has manufactured this luminaire in accordance with recognised best practices to recommended international safety standards. It is your responsibility to maintain this luminaire in good and safe working condition.

Repairs should only be carried out by suitably qualified persons. Do not operate the luminaire with cracked lens, damaged cables etc. Consult your Selecon distributor for assistance. Only replace damaged parts with authorised Selecon spares.

N.B. Luminaire Cable – your Selecon luminaire is fitted with a special heat-resistant, flexible cable, replace with genuine Selecon spare part cable kit only – refer to your Selecon distributor. (Replacement cables are supplied complete with necessary terminal connectors).

Cable Conductor colour codes:

Brown -Phase, Live  
Blue -Neutral, Return  
Green/ Yellow -Earth

## **PHYSICAL DATA (Fresnel) - Metric**

**Weight:** 3.3kg  
**Packed:** 3.7kg  
**Carton Size:** 420 x 225 x 175  
**Cubic:** 0.016  
**Colour Frame Size:** 125mm x 125mm

**Luminaire with integrated safety bond supplied with:**  
1 x colour frame, 1 x M12 nut & bolt set and instruction leaflet.

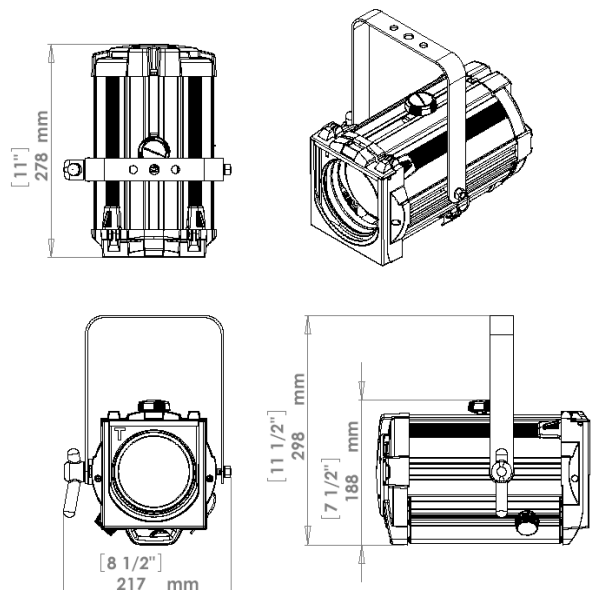

## LAMPS: 220V-240V

**500W T/25, T/18** 11,000 lumens  
400hrs average life  
**500W M40** 10,000 lumens  
2000hrs average life  
**650W T/26, T/27** 14,500 lumens  
600hrs average life

Tests conducted using a standard T27, 650W, 240V, 15,000 lumens lamp.

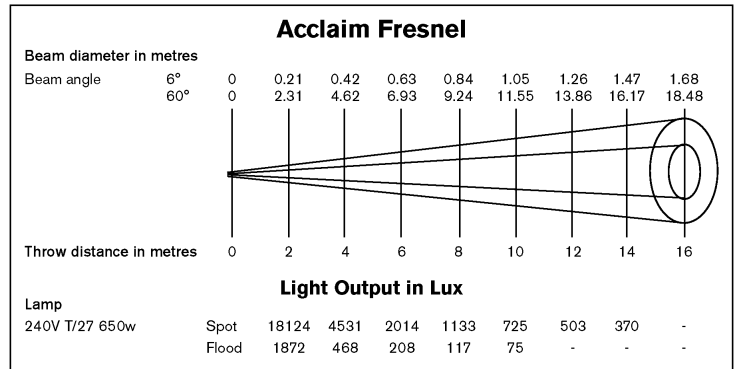

## PHYSICAL DATA (Fresnel) - US

**Weight:** 7lb 4oz  
**Packed:** 8lb  
**Carton Size:** 16 1/2" x 8 6/8" x 7"  
**Cubic:** 0.585 cu ft  
**Color Frame Size:** 4 7/8" x 4 7/8" square

**Fixture with integrated safety bond supplied with:** 1 x color frame, 1 x M12 nut & bolt set and instruction leaflet.

## LAMPS: 120V

**575W Ushio JCS120V-575WC**  
300hrs average life  
**575W Ushio JCS120V-575WX**  
1500hrs average life  
**650W FRK** 16,900 lumens  
200hrs average life  
**650W FRE** 15,000 lumens  
400hrs average life

Tests conducted using a standard FRK, 650W, 120V lamp.

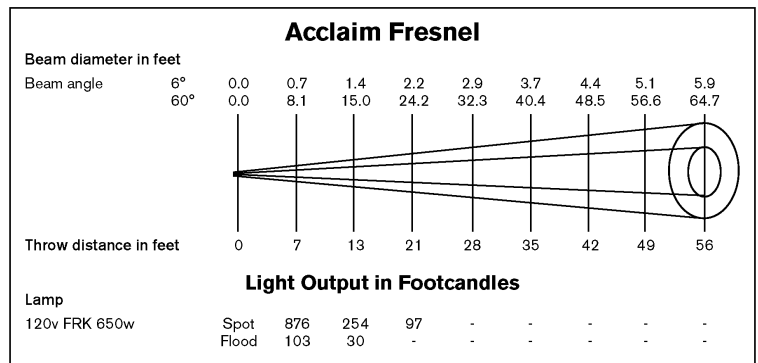

## PHYSICAL DATA (PC) - Metric

**Weight:** 3.5kg  
**Packed:** 3.9kg  
**Carton Size:** 460 x 225 x 175  
**Cubic:** 0.018  
**Colour Frame Size:** 125mm x 125mm

**Luminaire with integrated safety bond supplied with:** 1 x colour frame, 1 x M12 nut & bolt set and instruction leaflet.

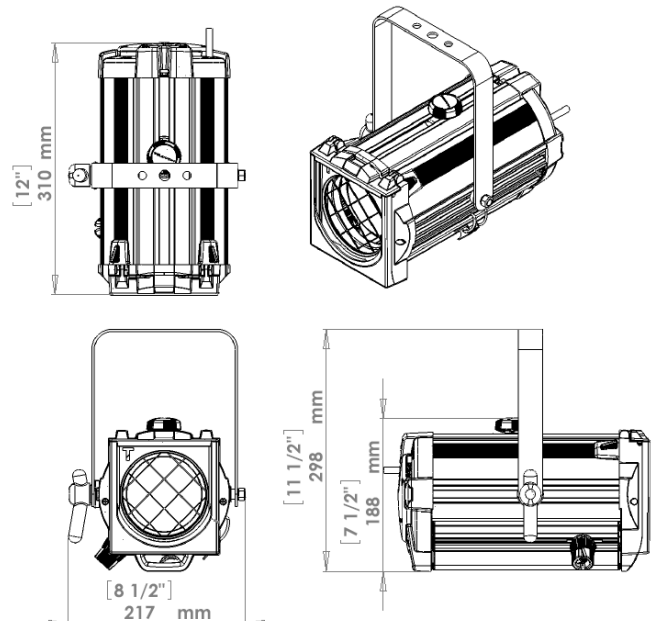

## LAMPS: 220V-240V

<b>500W T/25, T/18</b>	11,000 lumens
400hrs average life	
<b>500W M40</b>	10,000 lumens
2000hrs average life	
<b>650W T/26, T/27</b>	14,500 lumens
600hrs average life	

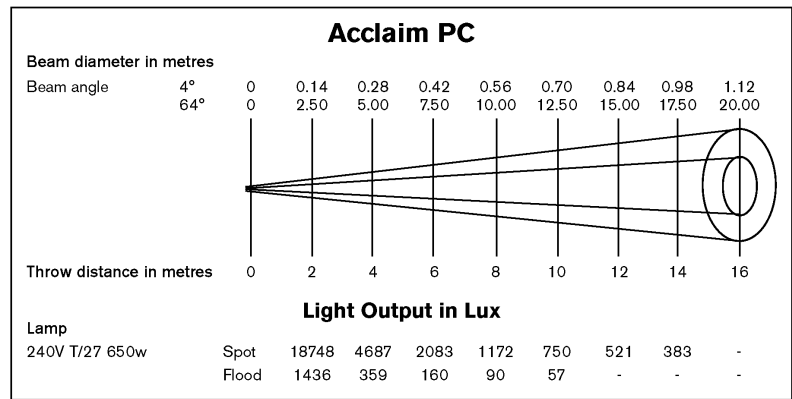

Tests conducted using a standard T27, 650W, 240V, 15,000 lumens lamp.

## PHYSICAL DATA (PC) - US

<b>Weight:</b>	7lb 12oz
<b>Packed:</b>	8lb 8oz
<b>Carton Size:</b>	18 x 8 6/8" x 7"
<b>Cubic:</b>	0.638 cu ft
<b>Color Frame Size:</b>	4 7/8" x 4 7/8" square

**Fixture with integrated safety bond supplied with:** 1 x colour frame, 1 x M12 nut & bolt set and instruction leaflet.

## LAMPS: 120V

<b>575W Ushio JCS120V-575WC</b>	300hrs average life
<b>575W Ushio JCS120V-575WX</b>	1500hrs average life
<b>650W FRK</b>	16,900 lumens
200hrs average life	
<b>650W FRE</b>	15,000 lumens
400hrs average life	

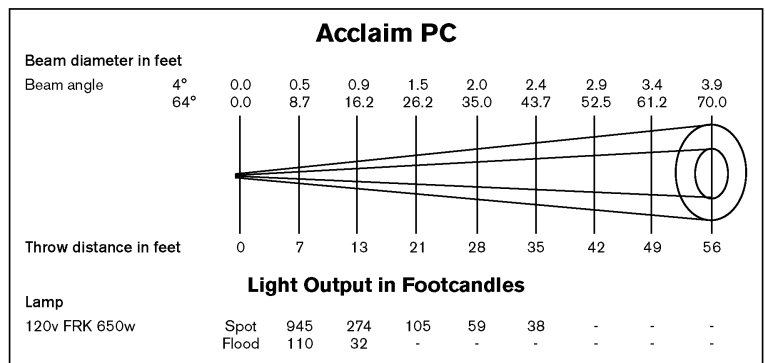

Tests conducted using a standard FRK, 650W, 120V lamp.

## LIMITED WARRANTY

**Selecon warrants its luminaires against defects in materials or workmanship. The term of this warranty is based on the product usage and is from the date of delivery.**

### Usage – Entertainment, Theatre

#### Term - Three Years

Entertainment, Theatre relates to the typical conditions found in a theatre performance venue viz: 4 – 6 hrs per day, six days per week.

### Other – ALL Electromechanical / Electronic Devices

#### Term - One Year

This warranty is void in any of the following circumstances:

- The luminaire has been misused, neglected, damaged or abused.
- The luminaire has been improperly installed, operated, repaired or maintained.

- (c) The luminaire has been modified.
- (d) The luminaire has been connected to other equipment with which it is not compatible.
- (e) The luminaire has been used or stored in conditions outside its electrical or environmental specifications.
- (f) The luminaire has been used for purposes other than for which it was designed.
- (g) The luminaire has been used outside its stated specifications and operating parameters.

Correct installation of the luminaire is the owner's responsibility.

To assert a warranty claim, complete the Selecon Return Authorisation Form (downloadable via the Selecon website: [www.strandlighting.com](http://www.strandlighting.com)). Return this with the luminaire to Selecon or its authorised agent.

If Selecon accepts the warranty claim, Selecon will provide, or arrange for, service, repair or replacement as Selecon shall determine in its sole discretion. Selecon shall bear the cost of such service, repair or replacement. However, the owner shall bear the cost of freight and insurance on the luminaire, both ways. If Selecon does not wish to service, repair or replace the defective luminaire, it shall refund the purchase price.

Selecon's sole responsibility is to repair, replace or service a luminaire subject to a valid warranty claim. Under no circumstance will Selecon be liable for direct, indirect, incidental, special or consequential costs or damages, including dismantling and re-installation costs, loss of operations or profits, to the maximum extent permitted by law.

Selecon accepts no liability for personal injury or property damage resulting from failure to heed relevant operating and safety procedures specified by Selecon or imposed by law.

This is an express warranty. Selecon disclaims any other express or implied warranties, including warranties of merchantability or fitness for purpose, to the maximum extent permitted by law.

Some jurisdictions do not allow limitations or disclaimers of implied or statutory warranties. Some jurisdictions do not allow disclaimers or exclusions of consequential or incidental damages. Therefore, the above disclaimers, limitations and exclusions may not apply in all jurisdictions in which Selecon sells its luminaires.

This warranty gives the owner specific legal rights. The owner may have other rights or remedies pursuant to the laws in its territory. Nothing in this limited warranty should be construed as limiting or restricting any other statutory right or remedy of the owner, except for such limitations or restrictions herein as may be allowed by the law of the territory.

Selecon has a policy of continual product improvement and specifications are subject to change without notice.

### **SELECON DISTRIBUTOR NETWORK**

Your Selecon distributor is a theatre professional with a broad knowledge and understanding of performance requirements. Most can offer you a full service including not only stage lighting equipment but, all your theatre needs including curtains, scenic paint, sound equipment, as well as supplies of lamps, filter, gaffer tape etc. The Philips Selecon dealer network is an international group of lighting professionals throughout Australasia, Asia, United Kingdom and Europe, North and South America.

[www.vari-lite.com](http://www.vari-lite.com)