

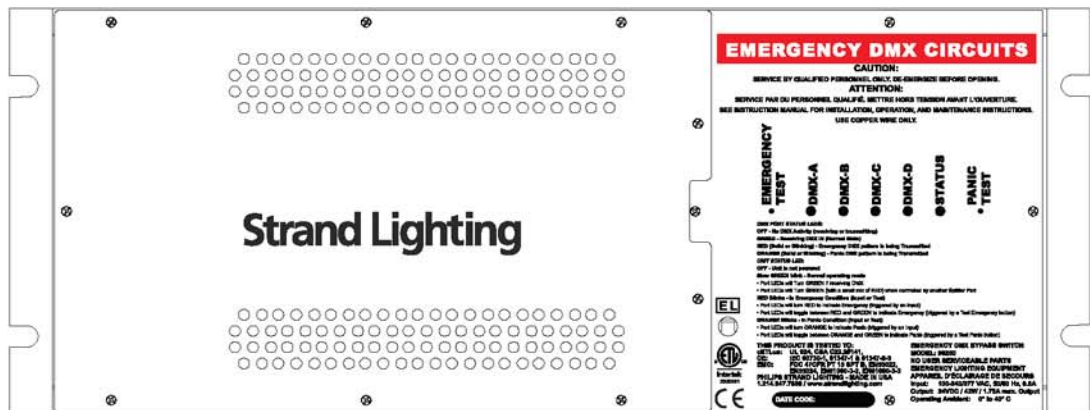

Emergency DMX Bypass Switch



MODEL: 96250

The material in this manual is for information purposes only and is subject to change without notice. Strand Lighting assumes no responsibility for any errors or omissions which may appear in this manual. For comments and suggestions regarding corrections and/or updates to this manual, please contact your nearest Strand Lighting office.

El contenido de este manual es solamente para información y está sujeto a cambios sin previo aviso. Strand Lighting no asume responsabilidad por errores o omisiones que puedan aparecer. Cualquier comentario, sugerencia o corrección con respecto a este manual, favor de dirijirlo a la oficina de Strand Lighting más cercana.

Der Inhalt dieses Handbuches ist nur für Informationszwecke gedacht, Aenderungen sind vorbehalten. Strand Lighting uebernimmt keine Verantwortung für Fehler oder Irrtuemer, die in diesem Handbuch auftreten. Für Bemerkungen und Verbesserungsvorschlaege oder Vorschlaege in Bezug auf Korrekturen und/oder Aktualisierungen in diesem Handbuch, moechten wir Sie bitten, Kontakt mit der naechsten Strand Lighting-Niederlassung aufzunehmen.

Le matériel décrit dans ce manuel est pour information seulement et est sujet à changements sans préavis. La compagnie Strand Lighting n'assume aucune responsabilité sur toute erreur ou ommission inscrite dans ce manuel. Pour tous commentaires ou suggestions concernant des corrections et/ou les mises à jour de ce manuel, veuillez s'll vous plait contacter le bureau de Strand Lighting le plus proche.

Information contained in this document may not be duplicated in full or in part by any person without prior written approval of Strand Lighting. Its sole purpose is to provide the user with conceptual information on the equipment mentioned. The use of this document for all other purposes is specifically prohibited. Certain features of the equipment described in this document may form the subject of patents or patent applications.

Document Number: **85-6418**
Version as of: **30 January 2023**

Emergency DMX Bypass Switch Installation Guide

IMPORTANT SAFEGUARDS

1. Safety Precautions

When using electrical equipment, basic safety precautions should always be followed including the following:



- a. **READ AND FOLLOW ALL SAFETY INSTRUCTIONS.**
- b. This device must be used in conjunction with approved EMERGENCY LIGHTING SYSTEM (with emergency power supply) as per National Electric Code.
- c. Do not use outdoors.
- d. Do not mount near gas or electric heaters.
- e. Equipment should be mounted in locations and at heights where it will not readily be subjected to tampering by unauthorized personnel.
- f. The use of accessory equipment not recommended by the manufacturer may cause an unsafe condition.
- g. Do not use this equipment for other than intended use.
- h. Refer service to qualified personnel. No field serviceable components.

SAVE THESE INSTRUCTIONS.

2. Warnings and Notices



WARNING: You must have access to a main circuit breaker or other power disconnect device before installing any wiring. Be sure that power is disconnected by removing fuses or turning the main circuit breaker off before installation. Installing the device with power on may expose you to dangerous voltage and damage the device. A qualified electrician must perform this installation.

WARNING: The unit is not permitted to be used without the connection to earth (ground).

WARNING: Refer to National Electrical Code® and local codes for cable specifications. Failure to use proper cable can result in damage to equipment or danger to persons.

WARNING: This equipment is intended for installation in accordance with the National Electric Code® and local regulations. It is also intended for permanent installation in indoor applications only. Before any electrical work is performed, disconnect power at the circuit breaker or remove the fuse to avoid shock or damage to the control. It is recommended that a qualified electrician perform this installation.

CAUTION: Wire openings **MUST** have fittings or lining to protect wires/cables from damage. Use 90° C copper wire only! Aluminum wire may not be used.

3. Compliance

This device is tested and in compliance with the following:

cETLus:	UL 924, CSA C22.2#141
CE:	IEC 60730-1, 61347-1 & 61347-2-3
EMC:	FCC 47CFR PT 15 SPT B, EN55022, EN55024, EN61000-3-2, EN61000-3-3

TABLE OF CONTENTS

Strand Lighting Offices	0
Important Safeguards	
Safety Precautions	1
Warnings and Notices	1
Compliance	1
Table of Contents	
Preface	
About This Guide	3
Important Safety Information	3
Overview	
About Emergency DMX Bypass Switch	4
Normal	4
Emergency	4
Emergency Learn	4
Emergency Test	4
Emergency Configuration	4
Panic	5
Sample System Diagram	5
Emergency DMX Bypass Switch External Features	6
Emergency DMX Bypass Switch Internal Features	6
Included Items	7
Installation	
Preparation & Overview	8
Tools List	8
Location and Clearances	8
Mounting	9
Network Wiring	11
DMX Universe Connections	11
Emergency / Panic Connections	12
Unit Settings	
Setting Unit DIP Switches	13
Mode (DMX Splitter) DIP Switch	13
Emergency Selection DIP Switch	14
Panic Selection DIP Switch	14
Status LEDs and Buttons	15
DMX Status LEDs (one for each DMX port)	15
Unit Status LED	15
Test Buttons	16
Notice To Contractor	
Technical Services Checkout Procedure	16
Product Specifications	
Electrical	17
Environmental	17
Mechanical	17

PREFACE

1. About This Guide

The document provides installation and operation instructions for the following products:

96250 Emergency DMX Bypass Switch

Please read this guide completely before installing or using this product.

Retain this guide for future reference.

2. Important Safety Information



WARNING: You must have access to a main circuit breaker or other power disconnect device before installing any wiring. Be sure that power is disconnected by removing fuses or turning the main circuit breaker off before installation. Installing the device with power on may expose you to dangerous voltage and damage the device. A qualified electrician must perform this installation.

WARNING: The unit is not permitted to be used without the connection to earth (ground).

WARNING: Refer to National Electrical Code® and local codes for cable specifications. Failure to use proper cable can result in damage to equipment or danger to persons.

WARNING: This equipment is intended for installation in accordance with the National Electric Code® and local regulations. It is also intended for permanent installation in indoor applications only. Before any electrical work is performed, disconnect power at the circuit breaker or remove the fuse to avoid shock or damage to the control. It is recommended that a qualified electrician perform this installation.

CAUTION: Wire openings MUST have fittings or lining to protect wires/cables from damage. Use 90° C copper wire only! Aluminum wire may not be used.

Note: This device must be used in conjunction with approved EMERGENCY LIGHTING SYSTEM (with emergency power supply) as per National Electric Code.



OVERVIEW

1. About Emergency DMX Bypass Switch

Strand Lighting's Emergency DMX Bypass Switch provides Emergency and Panic Lighting control solutions for DMX driven House Lights and DMX controlled Lighting used in emergency and egress lighting. Each Bypass unit can handle up to four (4) individual universes of DMX and can also act as a DMX splitter handling 1 in 4 out or 2 in 2 out routing scenarios. Bypass handles more than just emergency and has a separate trigger for Panic lighting states.

Each state - Panic or Emergency - can be set to trigger "captured snap shot" loads or can be set to drive all loads on each DMX path to 100%. Each state (Panic or Emergency) can be triggered via normally open, normally closed dry contacts, or from a 12VDC signal. Once the State is returned to Normal, the DMX Bypass Switch will also return loads to the DMX controller based upon a configured time.

Return states can be timed at 1 second, 10 seconds, 1 minute, 10 minutes, or can be set to return under INTELLIGENT timing. INTELLIGENT timing will shorten the return to normal bypass when Valid DMX inputs are sensed. Emergency DMX Bypass Switch is a simple affordable solution for all of your DMX Emergency and Panic systems needs.

Normal

Up to 4 separate DMX universes can be routed through the interface. The interface routes the signals from DMX IN directly to the DMX OUT connectors. The signals are routed through DPDT Relays (Common to Normally Closed contacts). The interface does not alter the DMX IN to DMX OUT in any way (direct connect). The interface can also be configured as a splitter. As a 1: 2 splitter, the interface will route DMX IN A to DMX OUT A and B, and DMX IN C to DMX OUT C and D. As a single 1:4 splitter, the interface will route a single DMX IN A to DMX OUT A, B, C, and D.

Emergency

When an Emergency signal is detected on the Interface's isolated Emergency Input port, it will activate the DMX coupling relays and disconnect the DMX IN from the DMX OUT ports. It will then output the saved Emergency DMX patterns to the connected lighting fixtures. It will continue to transmit the DMX patterns until the Emergency Input is removed and a configured time delay. After the time delay, the Relays are once again relaxed and the system returns to the Normal Mode.

Emergency Learn

A captured Emergency DMX pattern is 'learned' by first generating the required pattern at each DMX IN port - from a DMX output device such as a control console - while the unit is in Normal mode. An internal Emergency Learn pushbutton is then pressed and held for 3 seconds. The patterns that are received at each DMX IN port will then be recorded and saved in FLASH memory as the captured DMX pattern.

Emergency Test

The captured Emergency DMX pattern that was learned for each port can be periodically tested by pressing and holding the recessed Emergency Test pushbutton for three (3) seconds located on the Status Faceplate of the Interface. The Interface will then transmit the captured Emergency pattern out all the configured ports for up to 10 minutes or until the pushbutton is pressed a second time.

Emergency Configuration

DIP Switches are used to configure the Interface during Normal and Emergency Modes. The DIP switches can configure whether the Interface controls 4 independent DMX circuits, or acts as a Splitter. Two DIP Switches control the length of time the Interface continues to transmit the Emergency DMX patterns after the Emergency condition has been removed (1s, 10s, 1m, and 10m). A third DIP SW determines whether the Emergency DMX pattern is set to

transmit all slots at full (100%), or the captured (learned) Emergency pattern. A fourth DIP SW configures Emergency Input to function in a Normally Open or Normally Closed condition.

Panic

Functions the same as the Emergency mode except that it can be programmed to transmit a different pattern if desired. Panic uses a separate Panic Input, Panic Learn and Test pushbuttons, and separate configuration DIP Switches.

Note: Emergency Mode will always take precedence over the Panic Mode. When connected to a fire alarm system, local fire alarm codes and fire control system instructions must be followed. This device must be used in conjunction with approved EMERGENCY LIGHTING SYSTEM (with emergency power supply) as per National Electric Code.

2. Sample System Diagram

Figure 1 shows a sample riser diagram integrating the Emergency DMX Bypass Switch into a DMX system. Please refer to your shop drawings for your specific system configuration.

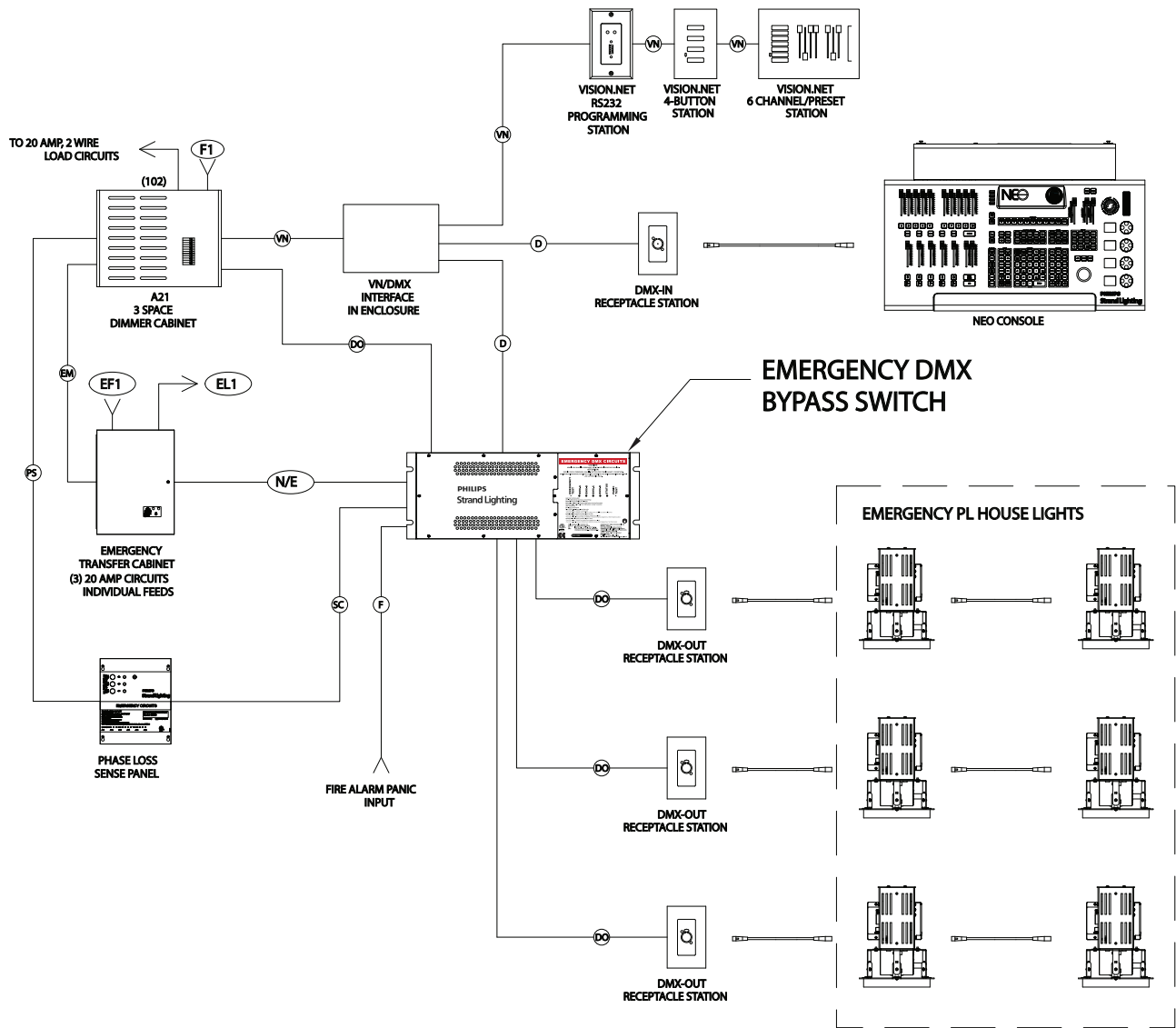

Figure 1: Sample System Diagram

3. Emergency DMX Bypass Switch External Features

Figure 2 shows the external layout of the Emergency DMX Bypass Switch.

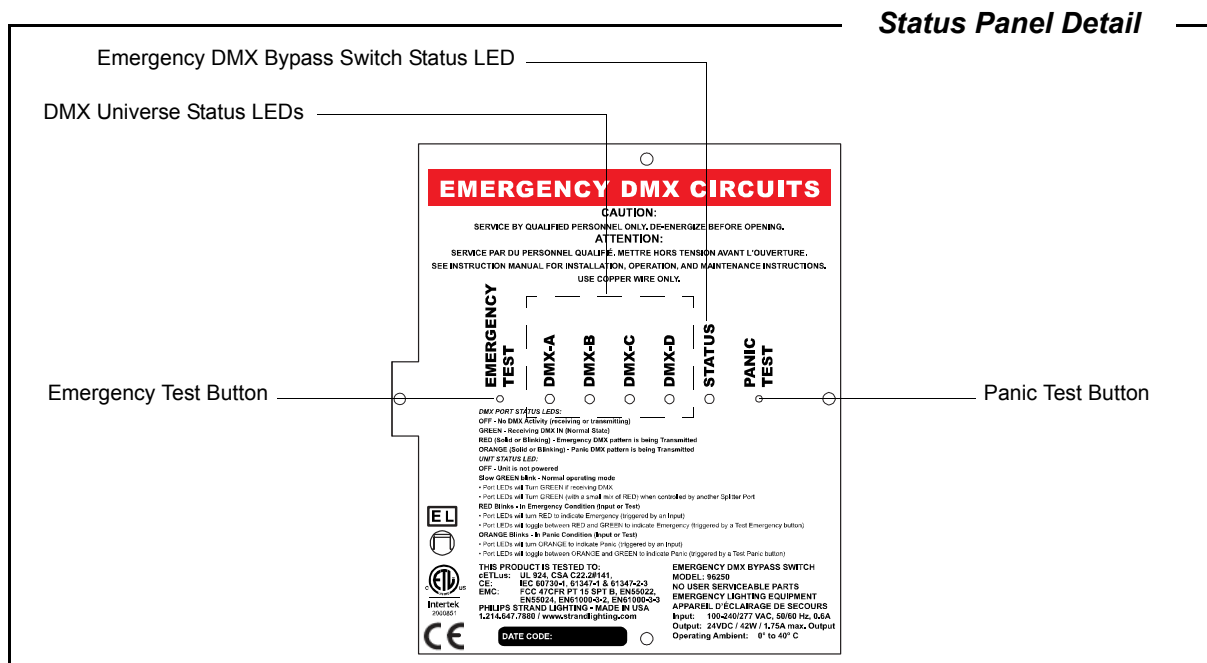
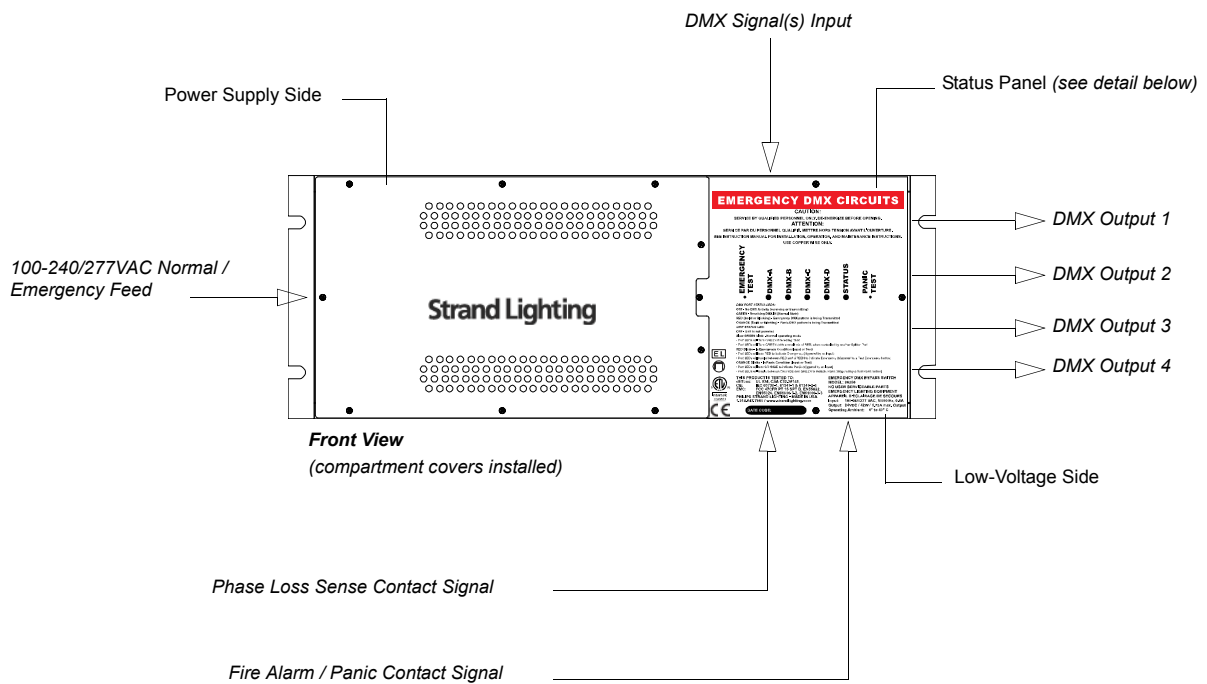

Figure 2: Emergency DMX Bypass Switch Overview

4. Emergency DMX Bypass Switch Internal Features

Figure 3 on page 7 shows the printed circuit board and its connections inside the Emergency DMX Bypass Switch.

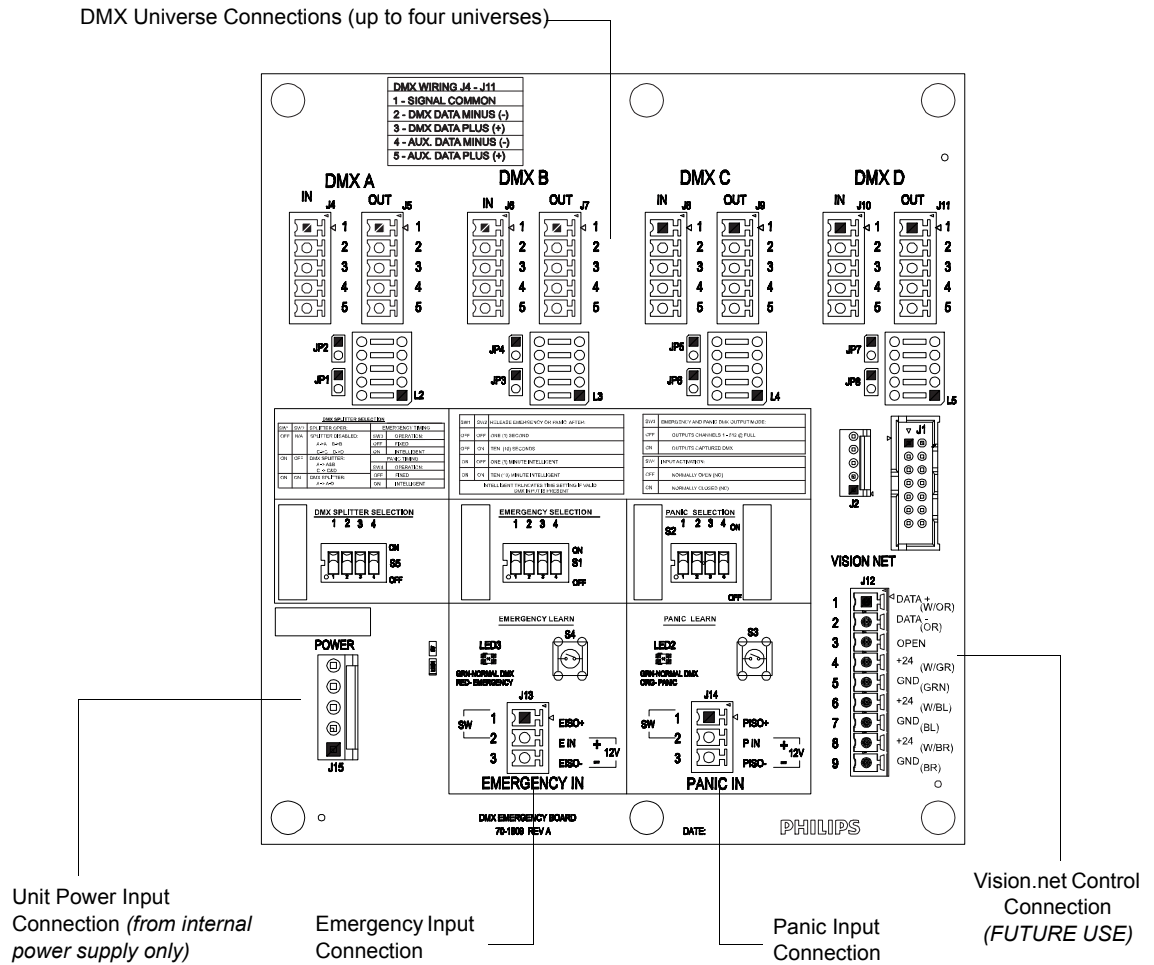
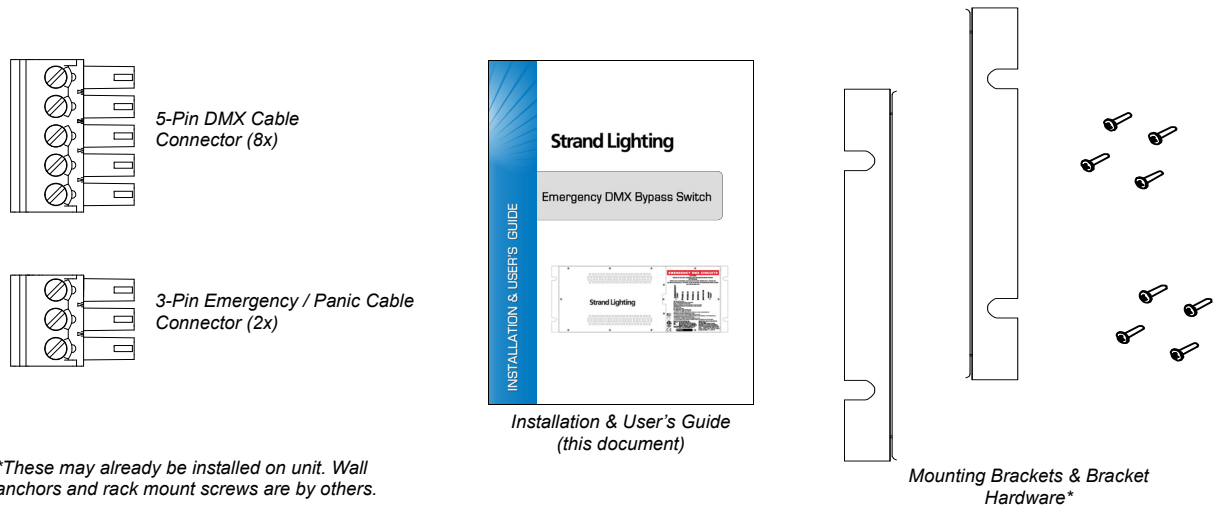

Figure 3: Emergency DMX Bypass Switch PCB Connections

5. Included Items

Included with your Emergency DMX Bypass Switch is the following items.



*These may already be installed on unit. Wall anchors and rack mount screws are by others.

Figure 4: Included Items

INSTALLATION

1. Preparation & Overview

The following steps are required to successfully install this product:

- 1) Review this document completely before starting the installation.
- 2) Unpack and inspect equipment. Compare the equipment you received with your packing list. If these do not match, contact Vari-Lite Customer Service at: 1-214-647-7880.
- 3) Gather tools. (Refer to [Tools List](#) below.)
- 4) Choose an appropriate location for installation. The unit should be installed in an area of "office" level cleanliness. The room in which it is installed should have sufficient volume to allow exhaust air to circulate and cool. (For more details and clearance requirements, refer to Location and Clearances below.)
- 5) Plan the wire routings and connection order. Decide where the Feed, Load, and Control wiring will enter the unit(s).
- 6) Remove access panels and knockouts in the unit as required for conduit or busway entry. Perform all conduit connections to the unit before it is permanently installed. Be sure to remove all knockout debris.
- 7) Securely mount the unit and terminate all Feed, Load, and Control wiring following the directions in this manual.
- 8) Clean up the work site and unit(s) for checkout by Strand Lighting Technical Services (see ["Notice To Contractor" on page 16](#)).
- 9) Contact Strand Lighting when ready for checkout.

2. Tools List

The following is a basic list of tools that may be required for this installation:

- Drill (for mounting holes)
- Hammer (for removing knockouts)
- Phillips screwdriver
- Small flat screwdriver
- Adjustable wrench
- Wire stripper
- Heatshrink tubing
- Pencil
- Knife
- Wire cutter
- Ratchet and assorted sockets
- 1/2-inch conduit and fittings
- Digital voltmeter/RMS

3. Location and Clearances

When installing this product, the location site **MUST** meet the following requirements:

- If wall mounting, wall and mounting hardware (*not supplied, by others*) must be capable of supporting the weight of the unit.
- Allow 4 inches above and below the unit to ease cover removal and installation and to allow air flow.
- Unit should be mounted in the horizontal position for optimum heat dissipation.
- Indoor Use Only: The unit **MUST** be installed indoors.
- Dry Locations Only: The unit can only be installed in an "office clean" area that is never exposed to moisture of any kind. Strand Lighting is not responsible for damage to equipment caused by moisture, paint, dust, solvents or cleaning supplies.
- Refer to National Electrical Code® and local codes to determine whether additional requirements must be met.

4. Mounting

The Emergency DMX Bypass Switch can be wall-mounted or rack-mounted using the included mounting brackets. Knockout holes in the unit's housing can be used to route power wiring and network cables as required. Unit may be mounted horizontally or vertically (wall mount) or horizontally (rack mount - 4U / 7-inches).

To install:

- Step 1. Unpack unit and inspect for any signs of shipping damage.
- Step 2. Locate suitable location for mounting unit. Refer to "[Location and Clearances](#)" on page 8 for additional information.

Note: Secure Emergency DMX Bypass Switch to a permanent structure using suitable mounting hardware (not supplied) in accordance to local and national codes (as applicable).

- Step 3. If necessary, reconfigure mounting brackets (supplied) for wall or rack mounting as shown in **Figure 5**.

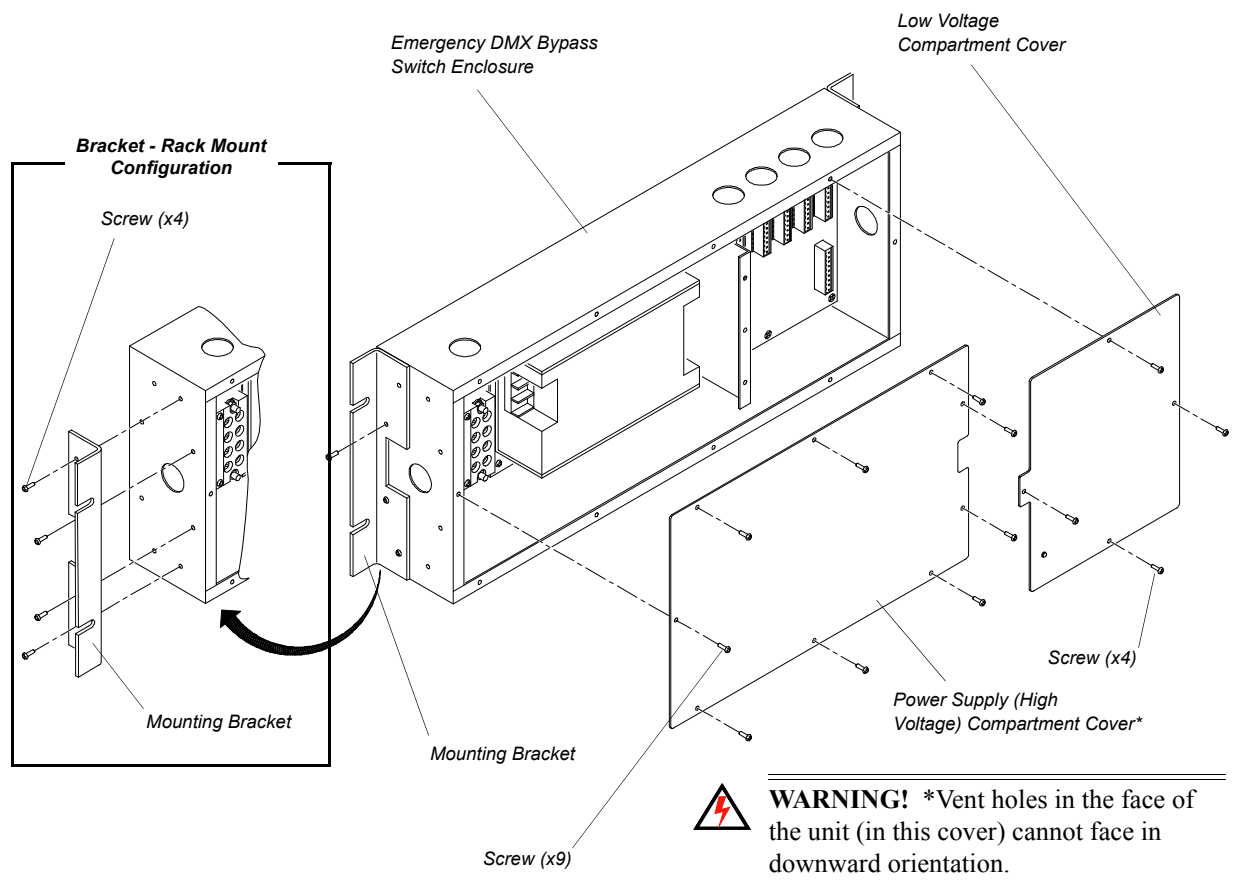

Figure 5: Configuring Mounting Brackets & Removing Covers

- Step 4. Install unit.
- Step 5. Remove covers from High Voltage and Low Voltage compartments.



WARNING! Ensure that power is removed from house service before connecting any wiring or cables to the Emergency DMX Bypass Switch. This unit is not permitted to be used without the connection to earth (ground).

- Step 6. Remove power from house service.



CAUTION: Knockouts are designed for 1/2-inch conduit and are to be punch towards inside of unit. When punching knockouts, be careful not to damage printed circuit board, power supply, or internal wiring.

Step 7. As required, remove knockouts as shown in **Figure 6**.

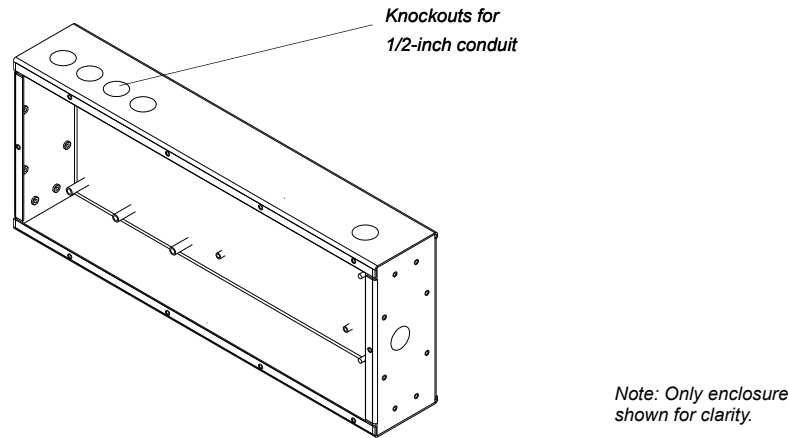

Figure 6: Emergency DMX Bypass Switch Enclosure Knockouts

Step 8. Route power input wires and network cables as shown in **Figure 7**. See "[Network Wiring](#)" on page 11 for connections.

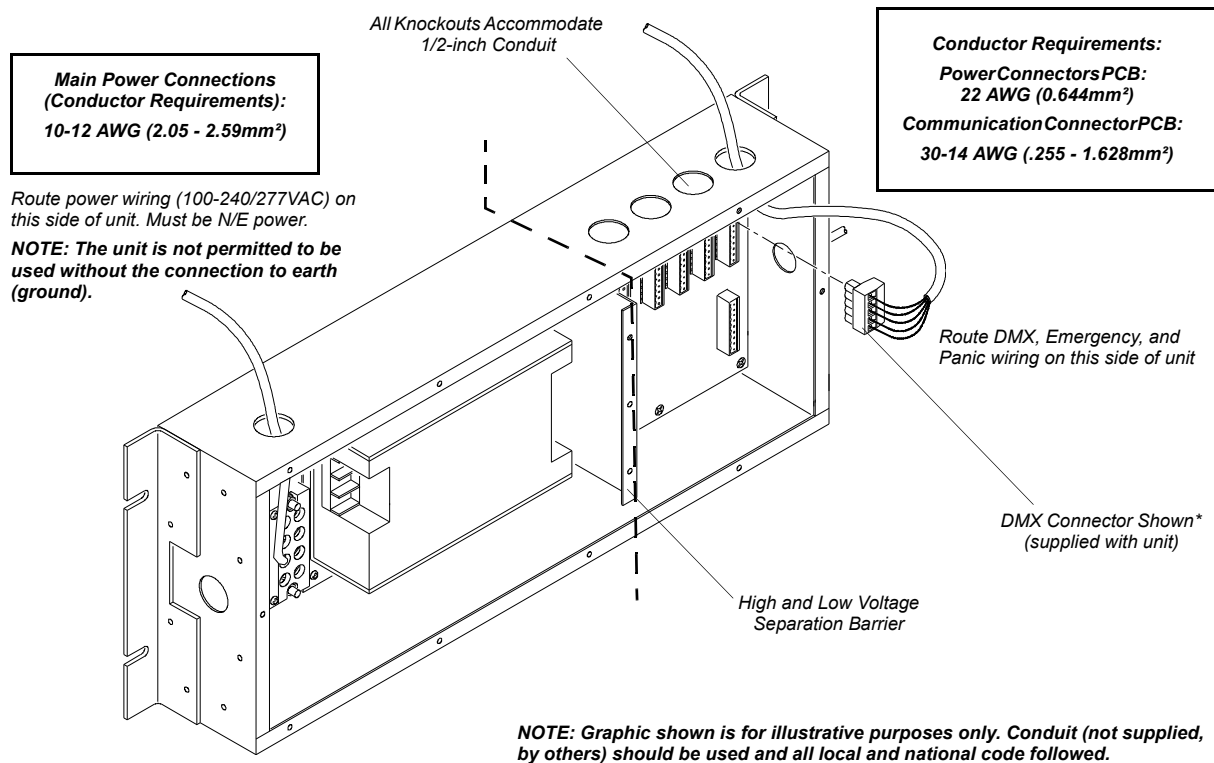

Figure 7: Power Input and Network Wire Routing

Note: *DMX, Emergency, and Panic connections are accomplished with supplied connectors (shipped with unit). See "[Included Items](#)" on page 7.

Step 9. Connect power wiring as shown in Figure 8.

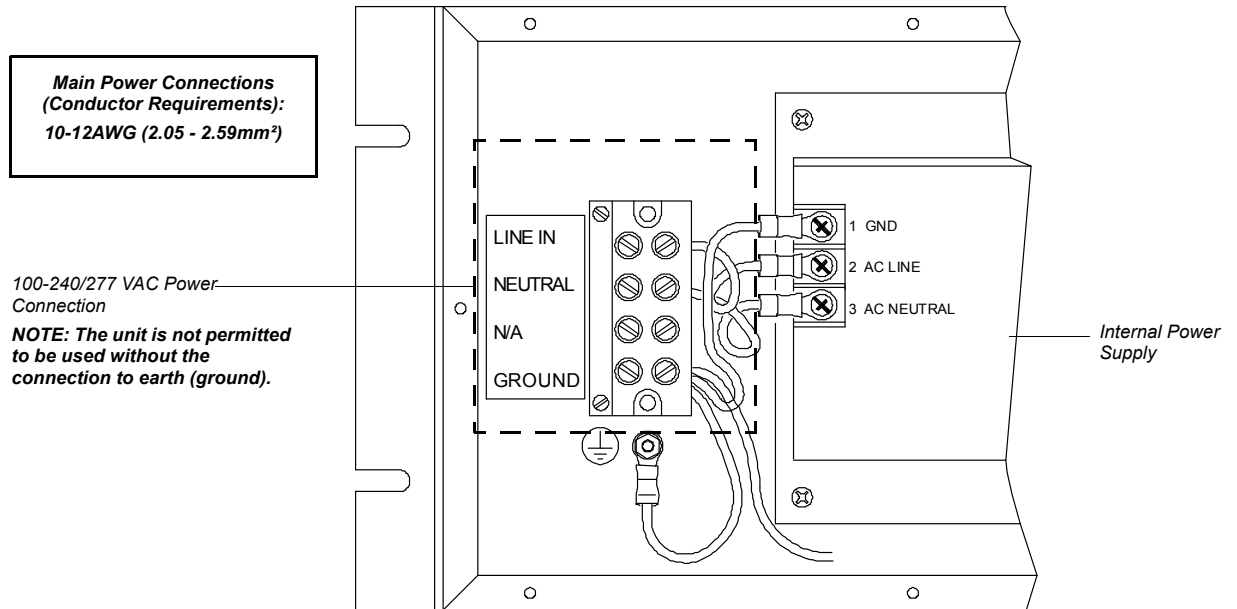

Figure 8: Input Power Connections



WARNING! Only use the supplied internal power supply. *The unit is not permitted to be used without the connection to earth (ground).*

Step 10. Re-install compartment covers (Figure 5).

Step 11. After all network (low-voltage) connections are done, re-apply house power service.

5. Network Wiring

DMX Universe Connections

The Emergency DMX Bypass Switch provide connections for up to four DMX universes. Figure 9 illustrates the internal connections and connection pin outs

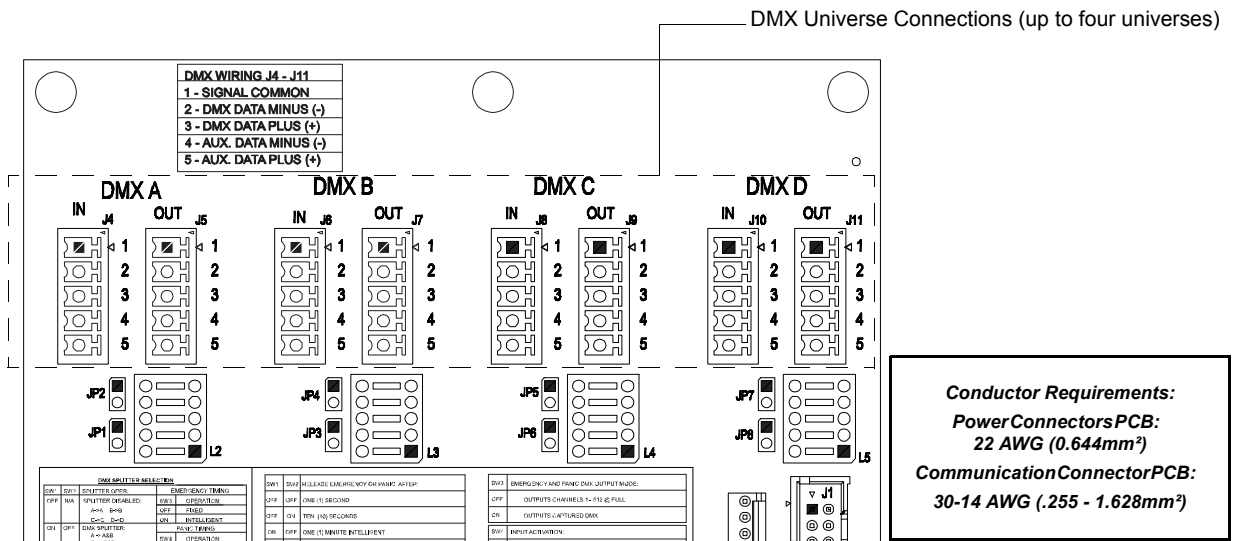

Figure 9: DMX Universe Connections



WARNING! Only use the supplied internal power supply.

Emergency / Panic Connections

The Emergency DMX Bypass Switch is supplied with mating connectors for Emergency and Panic signal connections. The printed circuit board has silk-screened pin out information. **Figure 10** illustrates these connections.

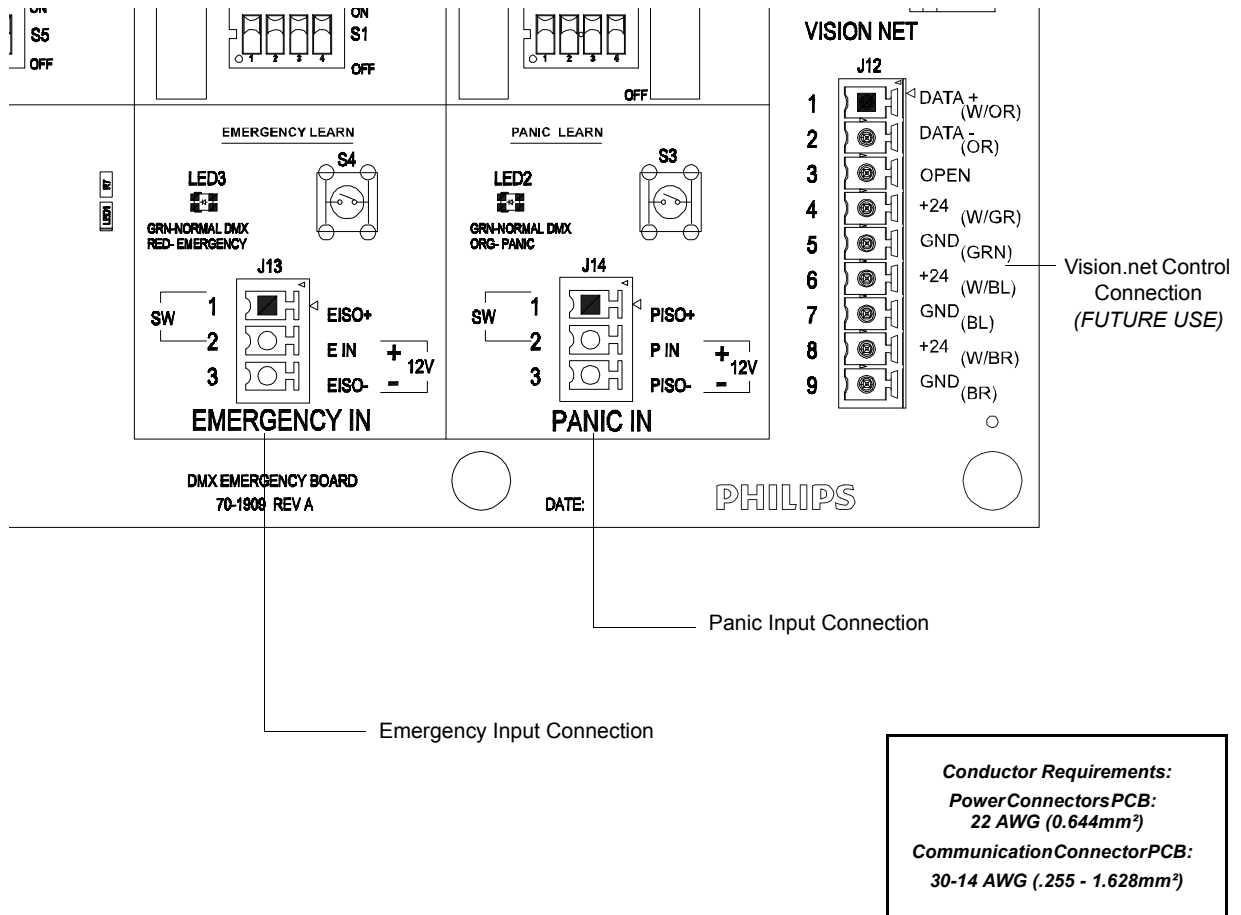

Figure 10: Emergency and Panic Input Connections

UNIT SETTINGS

1. Setting Unit DIP Switches

After making all connections, the unit is ready to set the operational DIP Switches.

Mode (DMX Splitter) DIP Switch

Set the mode DIP Switch as shown in **Table 1** and **Figure 11**.

Table 1: DMX SPLITTER SELECTION

SW1	SW2	SPLITTER OPERATION:	EMERGENCY TIMING*	
OFF	N/A	SPLITTER DISABLED <i>(one to one patch)</i> DMX A (In) ->DMX A (Out) DMX B (In) ->DMX B (Out) DMX C (In) ->DMX C (Out) DMX D (In) ->DMX D (Out)	SW3	OPERATION:
			OFF	FIXED
			ON	INTELLIGENT
ON	OFF	DMX SPLITTER <i>(one in patched to two out)</i> DMX A (In) -> DMX A & B (Out) DMX C (In) -> DMX C & D (Out)	PANIC TIMING*	
			SW4	OPERATION:
			OFF	FIXED
ON	ON	DMX SPLITTER <i>(one in patched to four out)</i> DMX A (In) -> DMX A,B,C,&D (Out)	ON	INTELLIGENT

*After setting this operational mode, see "[Emergency Selection DIP Switch](#)" on page 14 for time settings.

DMX SPLITTER SELECTION

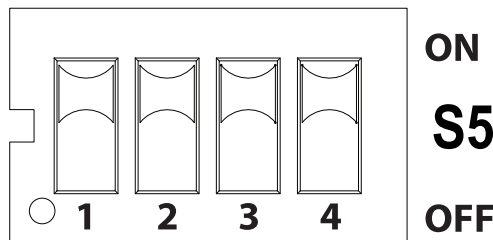

Note: Default DIP Switch settings shown.

Figure 11: Mode DIP Switch

Emergency Selection DIP Switch

Set the emergency DIP Switch as shown in **Figure 12**. For setting release parameter.

EMERGENCY SELECTION

S1

Note: Default DIP Switch settings shown.

Table 2: EMERGENCY DIP SWITCH SELECTION

SW1	SW2	RELEASE EMERGENCY AFTER
OFF	OFF	ONE (1) SECOND <i>(default)</i>
OFF	ON	TEN (10) SECONDS
ON	OFF	ONE (1) MINUTE FIXED OR INTELLIGENT*
ON	ON	TEN (10) MINUTES FIXED OR INTELLIGENT*
<i>NOTE: *INTELLIGENT SHORTENS THE TIME SETTING WHEN A VALID DMX INPUT IS PRESENT.</i>		
SW3	EMERGENCY AND PANIC DMX OUTPUT MODE:	
OFF	OUTPUTS CHANNELS 1 - 512 @ FULL	
ON	OUTPUTS CAPTURED DMX <i>(default)</i>	
SW4	INPUT ACTIVATION:	
OFF	NORMALLY OPEN (NO)	
ON	NORMALLY CLOSED (NC) <i>(default)</i>	

Figure 12: Emergency DIP Switch

Panic Selection DIP Switch

Set the panic DIP Switch as shown in **Figure 13**. For setting output mode and input activation parameters.

PANIC SELECTION

S2

Note: Default DIP Switch settings shown.

Table 3: PANIC SELECTION

SW1	SW2	RELEASE PANIC AFTER
OFF	OFF	ONE (1) SECOND <i>(default)</i>
OFF	ON	TEN (10) SECONDS
ON	OFF	ONE (1) MINUTE FIXED OR INTELLIGENT*
ON	ON	TEN (10) MINUTES FIXED OR INTELLIGENT*
<i>NOTE: *INTELLIGENT SHORTENS THE TIME SETTING WHEN A VALID DMX INPUT IS PRESENT.</i>		
SW3	EMERGENCY AND PANIC DMX OUTPUT MODE:	
OFF	OUTPUTS CHANNELS 1 - 512 @ FULL	
ON	OUTPUTS CAPTURED DMX <i>(default)</i>	
SW4	INPUT ACTIVATION:	
OFF	NORMALLY OPEN (NO) <i>(default)</i>	
ON	NORMALLY CLOSED (NC)	

Figure 13: Panic DIP Switch

2. Status LEDs and Buttons

The following describes the status LEDs and test buttons on located on the low-voltage compartment cover as indicated in **Figure 14**.

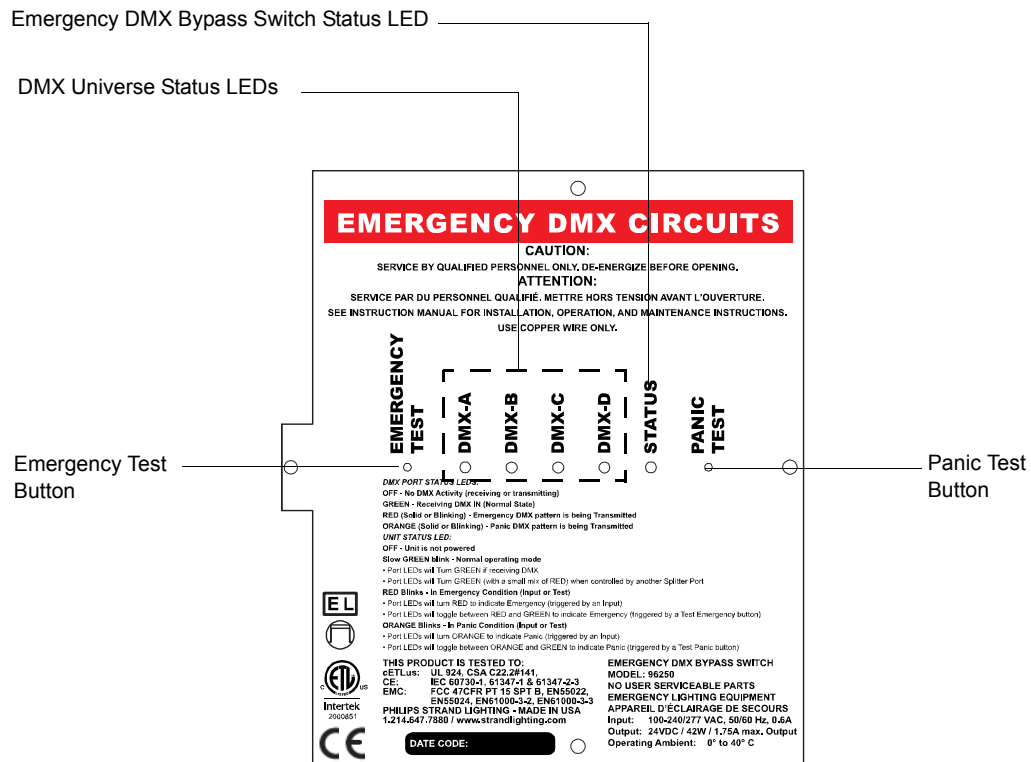

Figure 14: Status LEDs and Test Buttons

DMX Status LEDs (one for each DMX port)

- OFF - No DMX Activity (receiving or transmitting)
- GREEN - Receiving DMX IN (Normal State)
- RED (Solid or Blinking) - Emergency DMX pattern is being Transmitted
- ORANGE (Solid or Blinking) - Panic DMX pattern is being Transmitted

Note: In Splitter mode, the LEDs corresponding to the ports set up to receive DMX will turn GREEN to indicate Receiving DMX IN. The ports that are coupled to the Receiving port will also turn GREEN but with a small mix of RED (not fully ORANGE).

Unit Status LED

- OFF - Unit is not powered
- Slow GREEN blink for Normal operating mode
 - Port LEDs will Turn Green if receiving DMX
 - Port LEDs will Turn GREEN (with a small mix of RED) when controlled by another Splitter Port
- RED blinks indicate Emergency condition (Input or Test)
 - Port LEDs will turn Red to indicate Emergency (triggered by an Input)
 - Port LEDs will toggle between Red and Green to indicate Emergency (triggered by a Test Emergency button)

- ORANGE blinks indicate Panic condition (Input or Test)
 - Port LEDs will turn Orange to indicate Panic (triggered by an Input)
 - Port LEDs will toggle between Orange and Green to indicate Panic (triggered by a Test Panic button)

Test Buttons

The units contains two test buttons. One button is for triggering (testing) Emergency Mode. The other button is for triggering (testing) Panic mode.

- Hold for 3 seconds to trigger a mode test
- The mode test stays enabled for ten minutes and then automatically turns off OR,
- Press button at anytime to exit mode test.

NOTICE TO CONTRACTOR

Technical Services Checkout Procedure



DO NOT APPLY POWER TO THE LIGHTING CONTROL SYSTEM!

No part of this system may be energized or operated until the installation has been approved by a Vari-Lite Technical Services Representative. Violation of this Requirement may damage components and therefore constitute misuse under standard warranty terms. Such misuse may relieve Vari-Lite LLC of any and all further obligations under the terms of this warranty.

Equipment MUST be installed per the Vari-Lite drawings.

All installation and wire terminations MUST be completed per the Vari-Lite drawings *prior* to the arrival of the Technical Services Representative:

- 1) Input power must be connected to the system, but not energized. The unit is not permitted to be used without the connection to earth (ground).
- 2) All loads must be connected.
- 3) All control and signal wiring must be installed and terminated - including DMX512, Emergency, Panic, etc.
- 4) All equipment, including controllers, accessories, keys, cables and manuals must be in place.
- 5) Personnel for training (i.e. the users), as well as any other personnel required by contract and/or specification must be available for training at the completion of the Checkout and Energization.
- 6) An owner (or authorized representative), as well as any other personnel required by contract and/or specification will be present to accept the system.

The Technical Services Representative will only be able to:

- Ensure that the system is properly installed and functions correctly, including troubleshooting and providing guidance to the contractor to correct any problems.
- Train personnel in the operation of the Lighting Control System.

The Technical Services Representative will not be able to:

- Install equipment or make electrical connections required of the installing contractor, including DMX512, Emergency, Panic, and/or any other connections that require a licensed electrician.
- Return to instruct any personnel who missed the original training session.

If the above requirements have not been met, the Technical Services Representative will be required to leave the job site. Return trips to complete the Technical Services Checkout require a separate Purchase Order and will be invoiced at the cost of travel (including per diem and travel time door-to-door), hourly labor, and a minimum daily on-site charge. Rescheduling will require 3 weeks notice, subject to Technical Services Representative availability.

Please feel free to contact Vari-Lite Technical Services (1-214-647-7880) should there be any questions regarding the installation of the equipment or requirements regarding the Technical Services Checkout.

When all requirements have been met and the system is ready for inspection, please download and complete the **Field Service/Commissioning Request Form** (PDF). This form can be found on the Main Support Page of the Vari-Lite website: www.vari-lite.com

PRODUCT SPECIFICATIONS

1. Electrical

Input Power:	100-240/277VAC, 50-60Hz, 0.6 A, 1 Phase
Output Power:	24VDC, 42W / 1.75A
DMX Universes (Input):	4
Panic (Input):	1
Emergency (Input):	1

2. Environmental

Storage:	-25° to 85° C
Operating:	0° to 40° C
Relative Humidity:	5 to 95% (non-condensing)
Compliance:	cETLus: UL 924, CSA C22.2#141, CE: IEC 60730-1, 61347-1 & 61347-2-3 EMC: FCC 47CFR PT 15 SPT B, EN55022, EN55024, EN61000-3-2, EN61000-3-3

3. Mechanical

Color:	Black
Construction:	Steel Enclosure
Weight:	9.7 lbs.

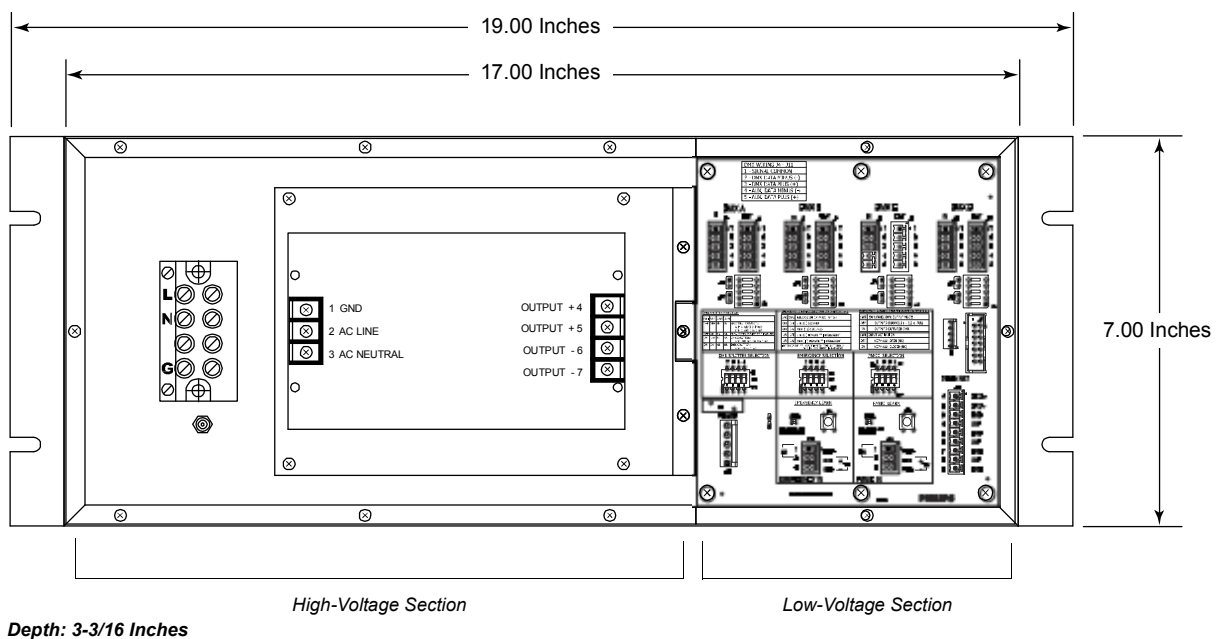

TECHNICAL SUPPORT

GLOBAL 24HR TECHNICAL SUPPORT:

Call: +1 214 647 7880

entertainment.service@signify.com

NORTH AMERICA SUPPORT:

Call: 877-VARI-LITE (877-827-4583)

entertainment.service@signify.com

EUROPEAN CUSTOMER SERVICE CENTER:

Call: +31 (0) 543 542 531

entertainment.europe@signify.com

© 2023 Signify Holding. All rights reserved. All trademarks are owned by Signify Holding or their respective owners. The information provided herein is subject to change, without notice. Signify does not give any representation or warranty as to the accuracy or completeness of the information included herein and shall not be liable for any action in reliance thereon. The information presented in this document is not intended as any commercial offer and does not form part of any quotation or contract, unless otherwise agreed by Signify. Data subject to change.