

Showline

SL HYDRUS 350



The SL HYDRUS 350 is a moving luminaire designed for special event, television and concert lighting applications. Powered by the Philips Platinum 17RA Lamp, the luminaire delivers powerful output, strong saturated colours and a comprehensive beam effects system in a compact sized luminaire.

Unlike traditional moving luminaires designed for a single purpose, the SL HYDRUS 350 has a hybrid optical design. Beam, spot and wash features are all combined in a single luminaire, maximising the return on your investment with a versatile luminaire that can perform as a true workhorse in your designs.

Showline

SL HYDRUS 350

FEATURES

- Fixed colour wheel with ten colours and one open slot
- Colour system allows for split colour mode and colour scroll effects
- Fixed gobo / beam aperture wheel containing twelve beam effect images
- Indexable / rotating gobo wheel with eight images. Includes a coloured layered multiple focal point gobo
- Animation wheel with Fire Breakup effect
- Four facet linear prism and eight facet circular prism
- Frost filter
- Auto focus mode

BENEFITS

- Use as a Beam luminaire: the SL HYDRUS 350 delivers a powerful, crisp pinpoint beam. Combine the fixed gobos and the rotating prism lenses to create striking designs that come to life in larger arenas and auditoriums.
- Use as a Spot luminaire: Choose the appropriate glass gobo (all designs from the Vari-Lite gobo library), rotate and combine with the animation wheel to produce a myriad of dynamic looks.
- Use as a Wash luminaire: Soften the edge with the frost filter and zoom out to deliver a defined soft even beam that can blend together and create smooth washes over the stage.

Showline

SL HYDRUS 350

SOURCE

Type	Philips Platinum 17RA Lamp
Wattage	350W
Color temp	7000k

OPTICAL PERFORMANCE

	beam mode		spot mode		wash mode	
Lumen output (max)	2°	10,700	2°	8,900	10°	3,400
	10°	14,000	12°	10,600	20°	4,700
	21°	15,000	25°	11,000	37°	5,400
Nominal color temperature	7000k					

BEAM

	beam mode	spot mode	wash mode
Beam angle	2-21°	2-25°	9-37°

POWER

Operating voltage	100-240VAC
Max wattage	500W

DATA CONNECTIONS

DMX	5-pin XLR in and thru
RJ45 data point	Input / thru
Powercon	Input / thru

DATA PROTOCOLS

DMX (RDM)	DMX-512A(RDM) via 5 pin XLR or over Ethernet
-----------	--

PHYSICALS

IP rating	IP20
Finish	Black
Construction	Metal frame, plastic covers

ENVIRONMENT

Operating temperature	-10-45°C (14-113°F)
Operating humidity	33-45

DIMENSIONS

	mm	in
H x W x L	420 x 654 x 431	16.5 x 25.7 x 17

WEIGHT

	kg	lb
Net weight	23.7	52.2
Packed weight	29.2	63.4

WARRANTY & APPROBATION

Warranty	2 years
Approbations	CE/C-Tick/cETL

Showline

SL HYDRUS 350

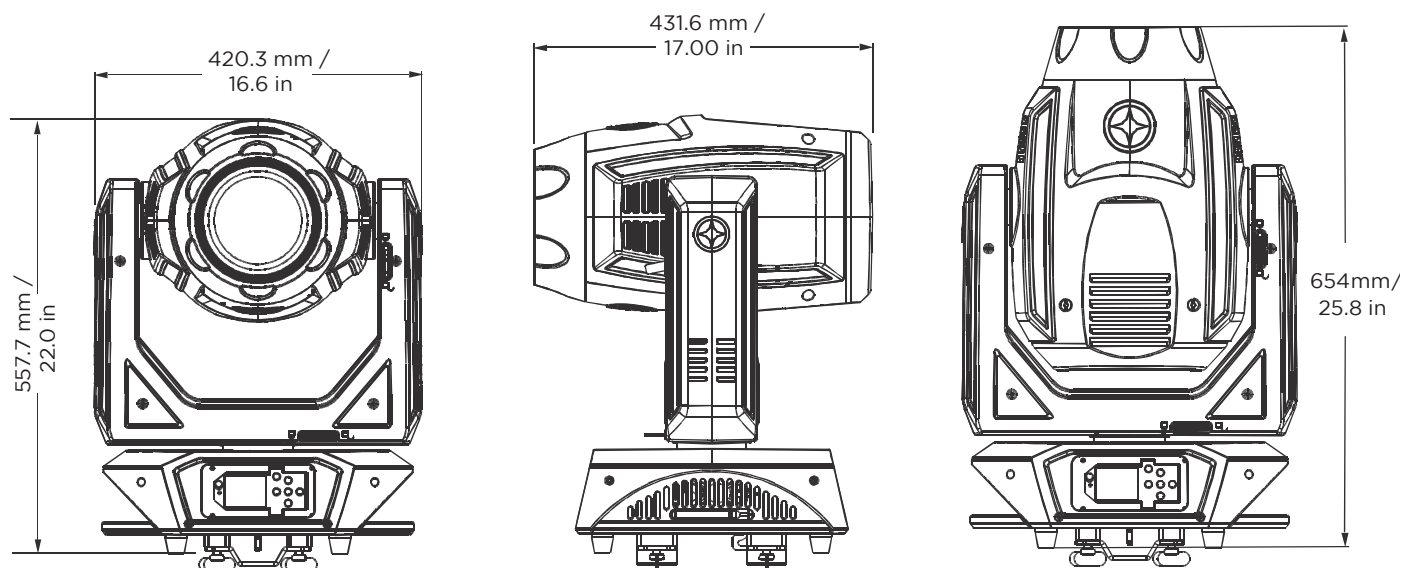

PRODUCT NAME

SL Hydrus 350 IP20

ORDER CODE

26-095-0110-00

© 2018 Signify Holding. All rights reserved.

All trademarks are owned by Signify Holding or their respective owners. The information provided herein is subject to change, without notice. Signify does not give any representation or warranty as to the accuracy or completeness of the information included herein and shall not be liable for any action in reliance thereon. The information presented in this document is not intended as any commercial offer and does not form part of any quotation or contract, unless otherwise agreed by Signify. Data subject to change.

Ref: 26-095-0110-00-100-v00