



Showline

SL PUNCHLITE 220

INSTALLATION & USER MANUAL

IMPORTANT INFORMATION

Warnings and Notices

When using electrical equipment, basic safety precautions should always be followed including the following:



- a. **READ AND FOLLOW ALL SAFETY INSTRUCTIONS.**
- b. Do not mount near gas or electric heaters.
- c. Equipment should be mounted in locations and at heights where it will not readily be subject to tampering by unauthorized personnel.
- d. The use of accessory equipment not recommended by the manufacturer may cause an unsafe condition.
- e. Do not use this equipment for other than intended use.
- f. Refer service to qualified personnel.

SAVE THESE INSTRUCTIONS.



WARNING: You must have access to a mains circuit breaker or other power disconnect device before installing any wiring. BE sure that power is disconnected by removing fuses or turning the mains circuit breaker off before installation. Installing the device with power on may expose you to dangerous voltages and damage the device. A qualified electrician must perform this installation.

WARNING: Refer to National Electrical Code® and local codes for cable specifications. Failure to use proper cable can result in damage to equipment or danger to personnel.

WARNING: This equipment is intended for installation in accordance with the National Electric Code® and local regulations. It is also intended for installation in indoor applications only. Before any electrical work is performed, disconnect power at the circuit breaker or remove the fuse to avoid shock or damage to the control. It is recommended that a qualified electrician perform this installation.

Additional Resources for DMX512

For more information on installing DMX512 control systems, the following publication is available for purchase from the United States Institute for Theatre Technology (USITT), "Recommended Practice for DMX512: A Guide for Users and Installers, 2nd edition" (ISBN: 9780955703522). USITT Contact Information:

USITT
315 South Crouse Avenue, Suite 200
Syracuse, NY 13210-1844
Phone: 1.800.938.7488 or 1.315.463.6463
www.usitt.org

Showline Limited Two-Year Warranty

Showline offers a two-year limited warranty of its luminaires against defects in materials or workmanship from the date of delivery. A copy of the Showline two-year limited warranty containing specific terms and conditions can be obtained by contacting your local Showline office.

TABLE OF CONTENTS

IMPORTANT INFORMATION	
Warnings and Notices	1
Additional Resources for DMX512	1
Showline Limited Two-Year Warranty	1
About this Manual	3
Included Items	3
SL PUNCHLITE 220 OVERVIEW	
SL PUNCHLITE 220 Components	4
INSTALLATION AND SET UP	
Connecting Power	6
Connecting SL PUNCHLITE 220 to AC Power	6
Connecting to the DMX512 Network	7
Mounting Luminaire	8
Truss / Hanging Applications	8
Floor Mounting	8
OPERATION AND PROGRAMMING	
LCD Display and Menu System	9
LCD Display and Menu System Operation	10
SL PUNCHLITE 220 Menu Tree	11
Quick Selection Buttons	13
Edit a Preset Button	13
Edit a Chase Button	13
DMX Address Button	13
Dimming Curve Selection	14
Primary / Auxiliary Operational Mode	15
DMX CONTROL	
SL PUNCHLITE 220 DMX Mapping	16
Simple 8-Bit Mode	16
Simple 8-Bit Group Mode	17
RGBW/RGBA 8-Bit Mode /	18
RGBWRGBA 8-Bit Group Mode	22
RGBWRGBA 16-Bit Mode	23
RGBW/RGBA 16-Bit Group Mode	27
HSIC Mode	28
HSIC Group Mode	29
DMX Timing Channel Detail	30
RDM PARAMETER IDs	
SL PUNCHLITE 220 RDM Parameter IDs	36
CLEANING AND CARE	
Special Cleaning and Care Instructions	39
Front Lens Cleaning	39
Service and Maintenance	39
TECHNICAL SPECIFICATIONS	
Operational Specifications	40
Luminaire Dimensions	41

PREFACE

1. About this Manual

The document provides installation and operation instructions for the following products:

- SL PUNCHLITE 220 Luminaire

Please read all instructions before installing or using this product. *Retain this manual for future reference.* Additional product information and descriptions may be found on the product specification sheet.

Note: The SL PUNCHLITE 220 luminaire works from 100 to 240 VAC (auto-ranging).

2. Included Items

Each SL PUNCHLITE 220 luminaire includes the following items:

- SL PUNCHLITE 220 Luminaire
- Quick Start Guide

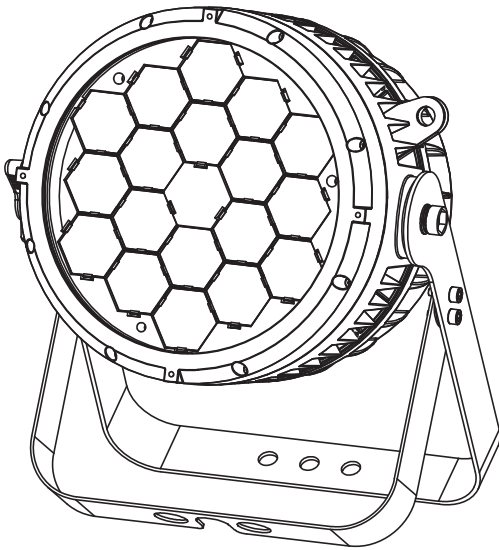

SL PUNCHLITE 220 Luminaire

US Market

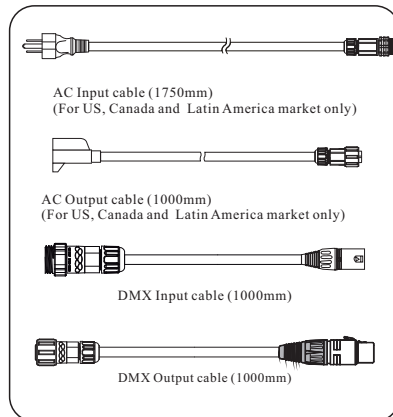

International Market

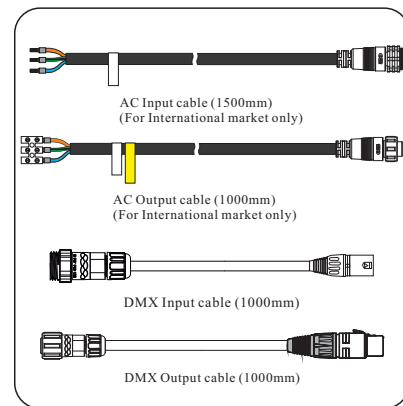

Cables

SL PUNCHLITE 220 OVERVIEW

1. SL PUNCHLITE 220 COMPONENTS

Common Luminaire Components

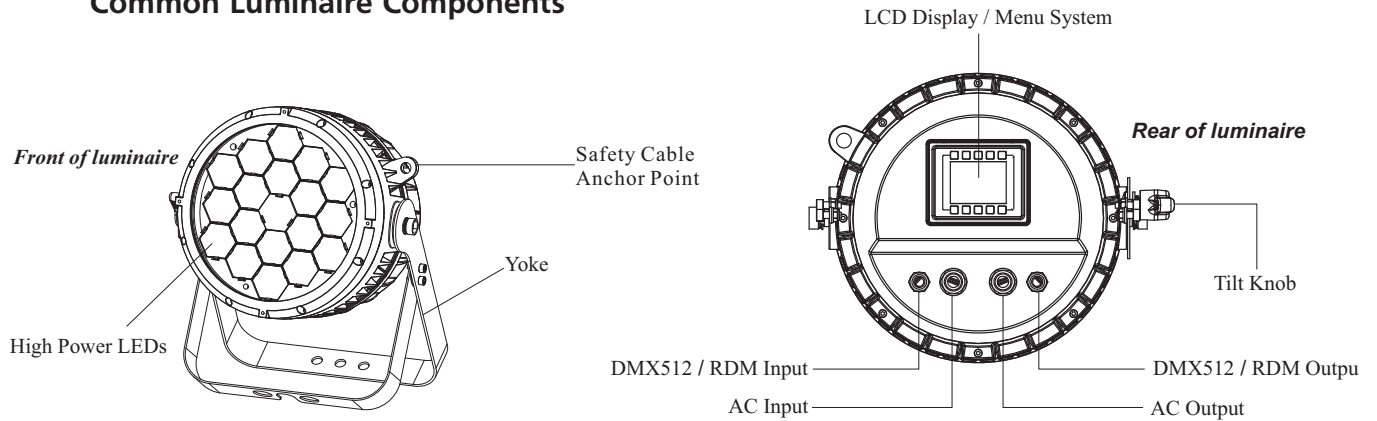
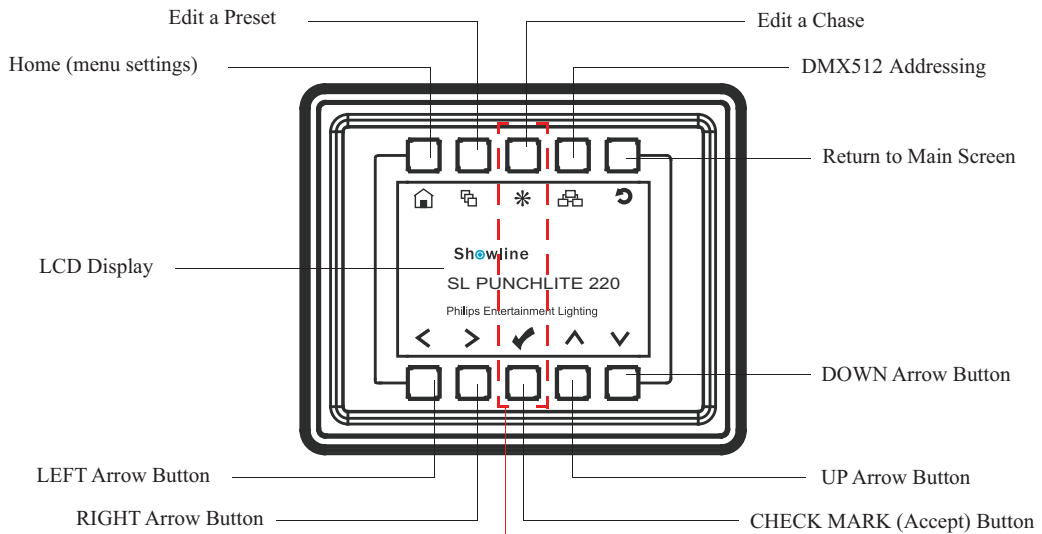

Figure 1: SL PUNCHLITE 220 Common Components

LCD Display / Menu System



NOTE: The menu rotates with the orientation of luminaire and the menu buttons are always in the same position (with rotation of menu)

To rotate the menu 180 degrees from the current orientation, press and hold the two center buttons for 2 seconds.

Figure 2: LCD Display & Menu System

Note: For Menu operation and programming details, refer to "LCD Display and Menu System" on page 9.

INSTALLATION AND SET UP

1. Power Requirements

The SL PUNCHLITE 220 Luminaire operates on AC input voltages from 100 to 240 VAC.



WARNING! The SL PUNCHLITE 220 luminaire does not have an ON/OFF switch. Always disconnect power input cable to completely remove power from the luminaire when not in use.

AC Power Operation

When connected to an AC source, the luminaire operates on 100 to 240 volts AC (+/- 10%, auto-ranging). The luminaire contains an auto-ranging power supply. Each luminaire can draw up to 220 Watts.



WARNING! Maximum amount of fixtures that may be daisy-chained is (A) 4 luminaires 100 ~ 120VAC or (B) 10 luminaire 230 ~ 240VAC (10 Amps).

Table 1: SL PUNCHLITE 220 Voltage (VAC) vs. Current*

Voltage (AC)	Total Current (A)	Voltage (AC)	Total Current (A)
100	2.20	180	1.22
110	2.00	190	1.16
120	1.83	200	1.10
130	1.69	210	1.04
140	1.57	220	1.00
150	1.46	230	0.96
160	1.37	240	0.92
170	1.29		

Note: For wiring of AC input connector, refer to "[Connecting SL PUNCHLITE 220 to AC Power](#)" on page 6.

2. Connecting Power

luminaires can be powered in one of two ways:

- Direct connection to an AC power source using an AC input cable. For wiring of the AC input connector, refer to "[Connecting SL PUNCHLITE 220 to AC Power](#)" on page 6.
- Connection from the AC output of another SL PUNCHLITE 220. When using this method, it is very important not to connect any other type of equipment device.



WARNING! Only connect other SL PUNCHLITE 220 luminaires to the AC Output (Thru) connector of an SL PUNCHLITE 220 luminaire.

Connecting SL PUNCHLITE 220 to AC Power

Table 2 describes how to connect power to your SL PUNCHLITE 220. Field wiring of the SL PUNCHLITE 220 LED Luminaire is straight-forward. A total of 3 wires/conductors need to be brought to the luminaire. The following wiring scheme is required:

Table 2: SL PUNCHLITE 220AC Input/Output Connections

Wire Color	Purpose
Brown	Main/Line(100 to 240VAC)
Blue	Neutral
Green/Yellow	Ground (Earth)

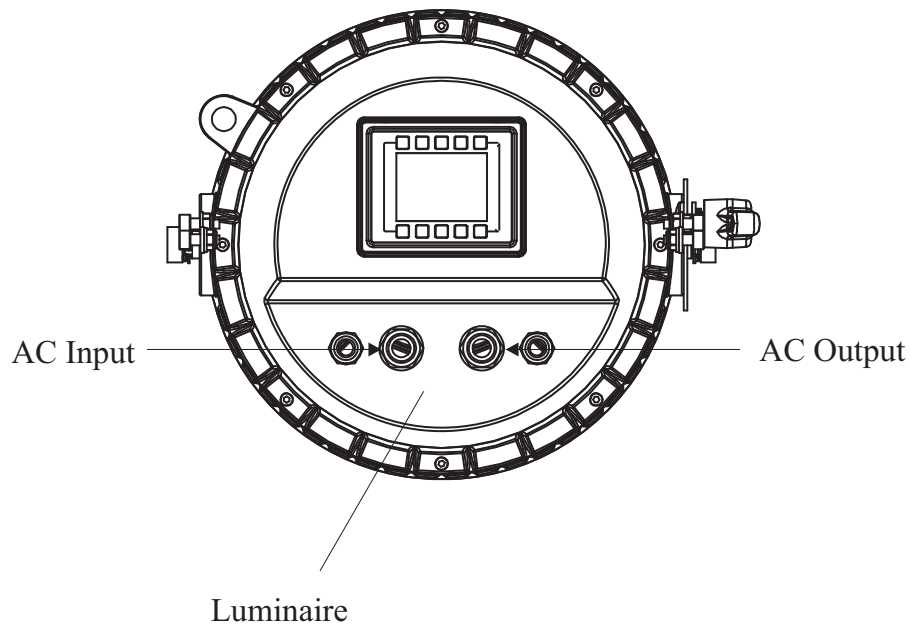

Figure 3: SL PUNCHLITE 220 AC Input & Output Connections

3. Connecting to the DMX512 Network

Basic DMX512 installation consists of connecting multiple SL PUNCHLITE 220s together (up to 32 luminaires) in "daisy-chain" fashion. A cable runs from the control console (or DMX512 control source) to the DMX connector on the first SL PUNCHLITE 220. Another cable runs from the other DMX connector on the first luminaire to a connector on the next SL PUNCHLITE 220 (or DMX512 device to be controlled).

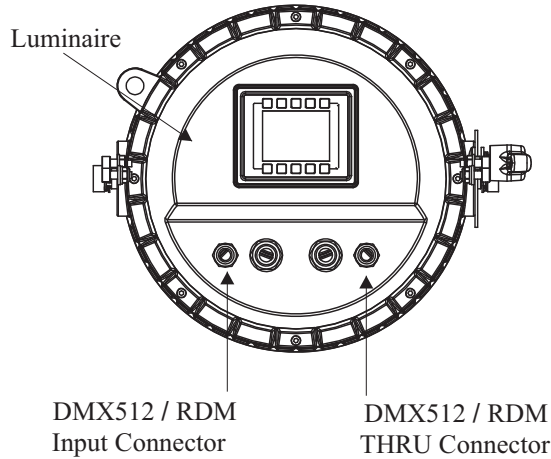
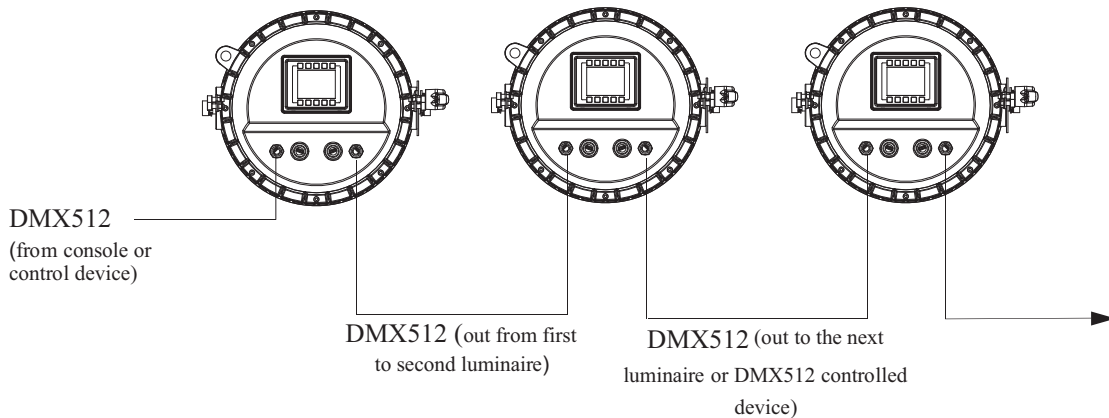

Figure 4: SL PUNCHLITE 220 DMX512 Input / Output Connections

Note: For more information on DMX512 networking and systems, refer to "Additional Resources for DMX512" on page 1. For SL PUNCHLITE 220 DMX Mapping, refer to "DMX CONTROL" on page 16.



DMX512 Connections		
DMX512 Signal	XLR Pin	Color
Common (Drain)	1	Black
DMX512-	2	White
DMX512+	3	Red

Note: Remaining pins on each connector are not used.

Figure 5: SL PUNCHLITE 220- DMX512 Connections

4. Mounting Luminaire

Truss / Hanging Applications

The SL PUNCHLITE 220 is provided with the ability to hang via truss hooks, clamps, etc. (sold separately). Simply attach hook, clamp, etc. to the SL PUNCHLITE 220 yoke in the provided M12 holes. It is recommended (and may be required by local and national safety codes) to use and install a safety cable (sold separately) as illustrated in Figure 6. When hanging the fixture, be sure to leave enough space around the luminaire to allow proper, uninterrupted airflow for cooling and movement. Refer to "[Luminaire Dimensions](#)" on page 36 for spacing (dimensional) requirements.

Note: Mounting hooks, clamps, safety cables, etc. are sold separately or by others. For mounting accessories available for this product, refer to "[Accessories](#)" on page 3.

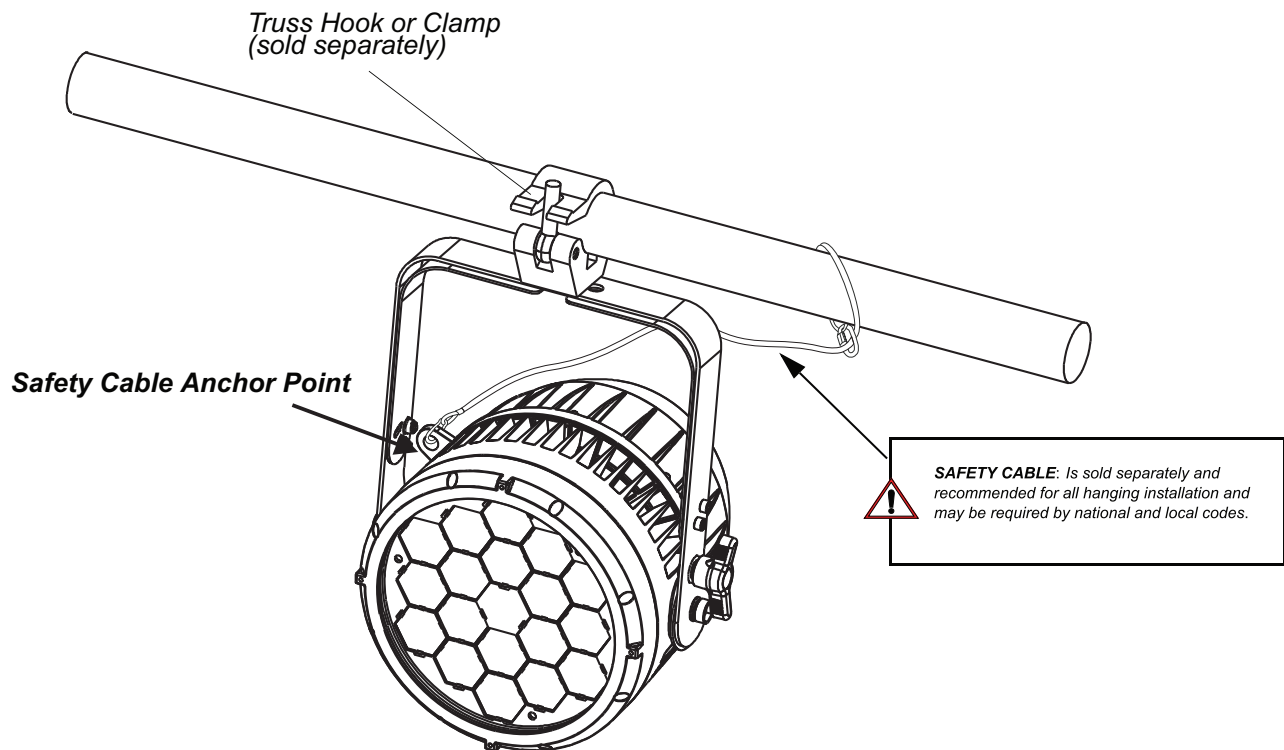

Figure 6: Mounting the Fixture - Hanging Applications

Floor Mounting

The SL PUNCHLITE 220 is designed to sit directly on its split yoke assembly in a floor installation application. When used in this type of application, be sure to leave enough space around the luminaire to allow proper, uninterrupted airflow for cooling and movement.

OPERATION AND PROGRAMMING

1. LCD Display and Menu System

SL PUNCHLITE 220

The SL PUNCHLITE 220's LCD Display and Menu System provides local control for accessing the following fixture's settings:

- Presets (Standard and User Defined)
- Color Filter
- Effects (Chases - preloaded and user defined)
- Strobe / Timing
- Settings
- Lock Fixture (to prevent changes)
- Password
- Status

Note: If there are multiple luminaires in a system, changes would need to be made at each LCD Menu as desired. For SL PUNCHLITE 220 menu structure, see "[SL PUNCHLITE 220 Menu Tree](#)" on page 11.

Upon power up, the LCD will display the main screen showing the product type/name. If DMX is enabled, the programmed address will appear after power up.

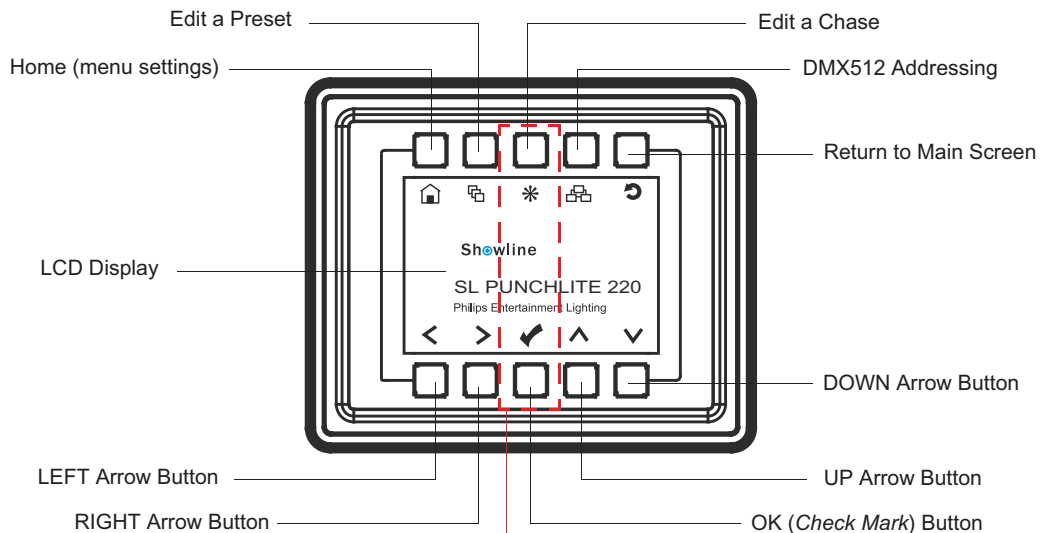

NOTE: Menu rotates with orientation of Luminaire and menu buttons are always in the same position (with rotation of menu)

To rotate menu 180 degrees manually from current orientation, press and hold the two center buttons for 2 seconds.

Figure 7: LCD Display and Menu System

2. LCD Display and Menu System Operation

The LCD Display Menu system consists of several categories. Use the Menu Buttons to access and make changes to the menu items. When the desired menu item is reached, press the desired Menu Button to display the menu options and to navigate and configure the menu options as required.

To navigate and access menu settings/selections:

Step 1. Make sure luminaire is powered and turned on.

Step 2. Press the desired button (as shown in **Figure 8**) to access menu categories.

Step 3. Use UP | DOWN | LEFT | RIGHT arrow buttons to navigate through the various options and settings.

Step 4. Make changes as desired.

Press CHECK MARK (OK) button to accept changes.

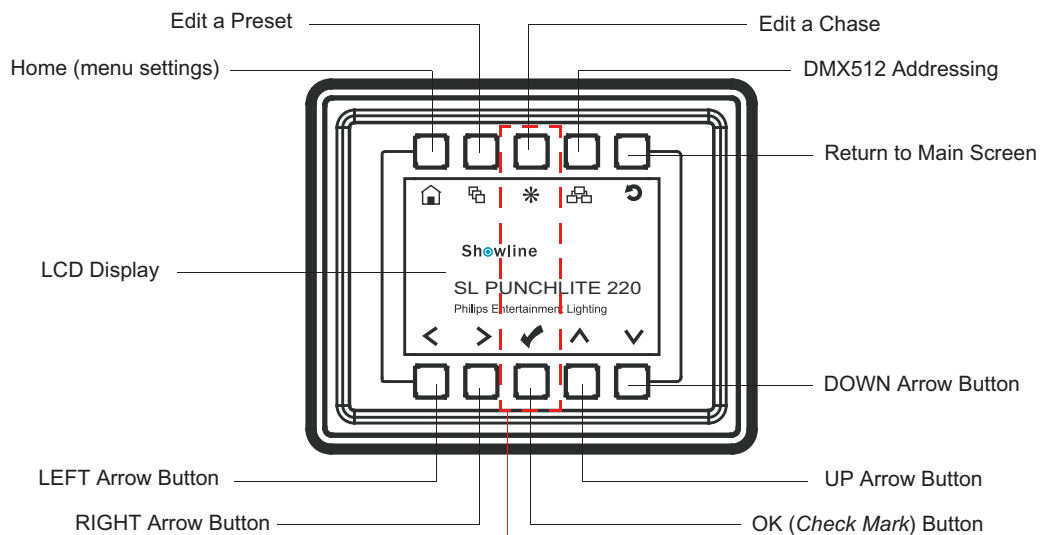

NOTE: Menu rotates with orientation of Luminaire and menu buttons are always in the same position (with rotation of menu)

To rotate menu 180 degrees manually from current orientation, press and hold the two center buttons for 2 seconds.

Figure 8: LCD Display and Menu System

3. SL PUNCHLITE 220 Menu Tree

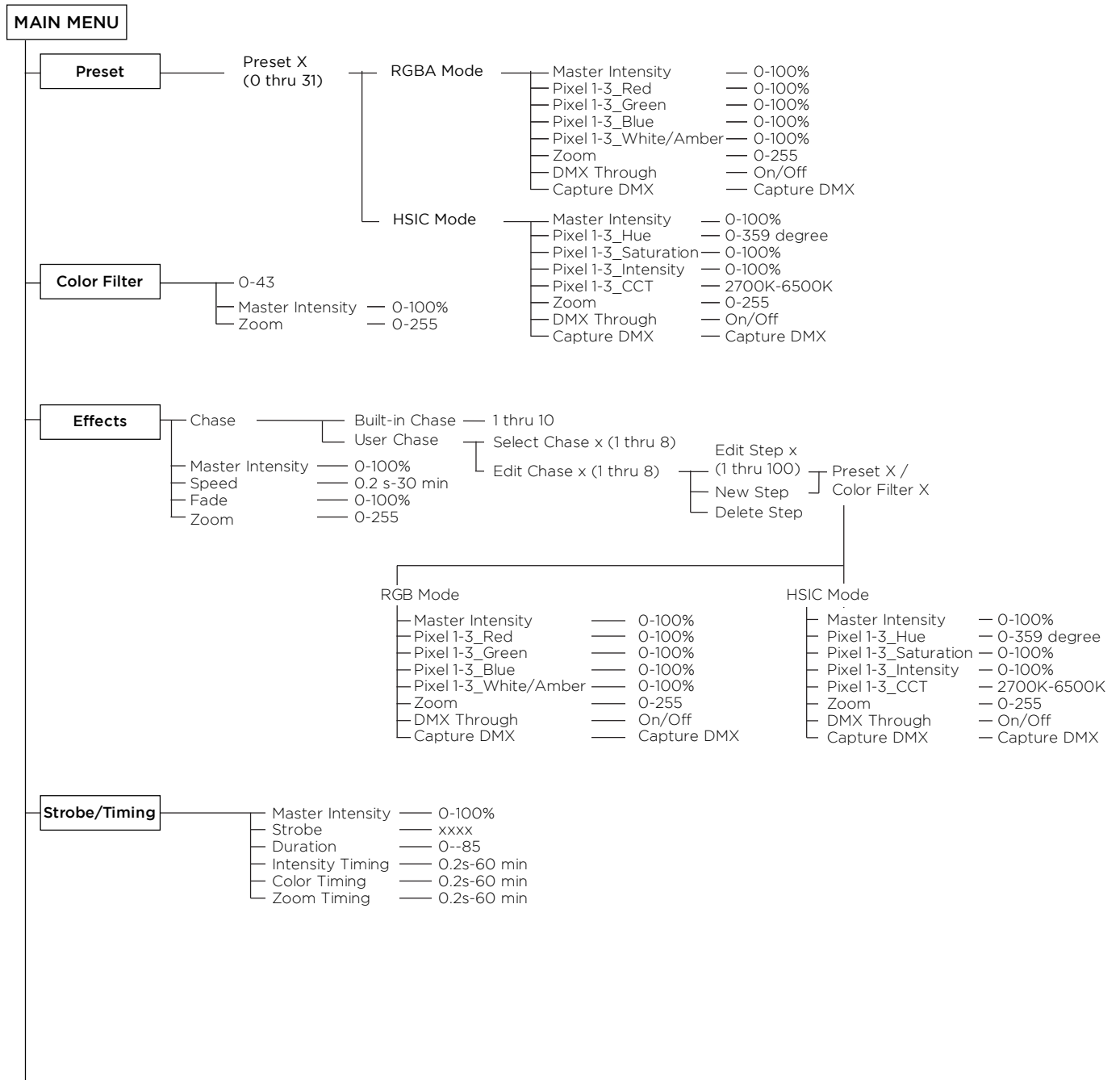

Continue on next page

Figure 9: SL PUNCHLITE 220 Menu Tree(Part 1)

Continued from previous page

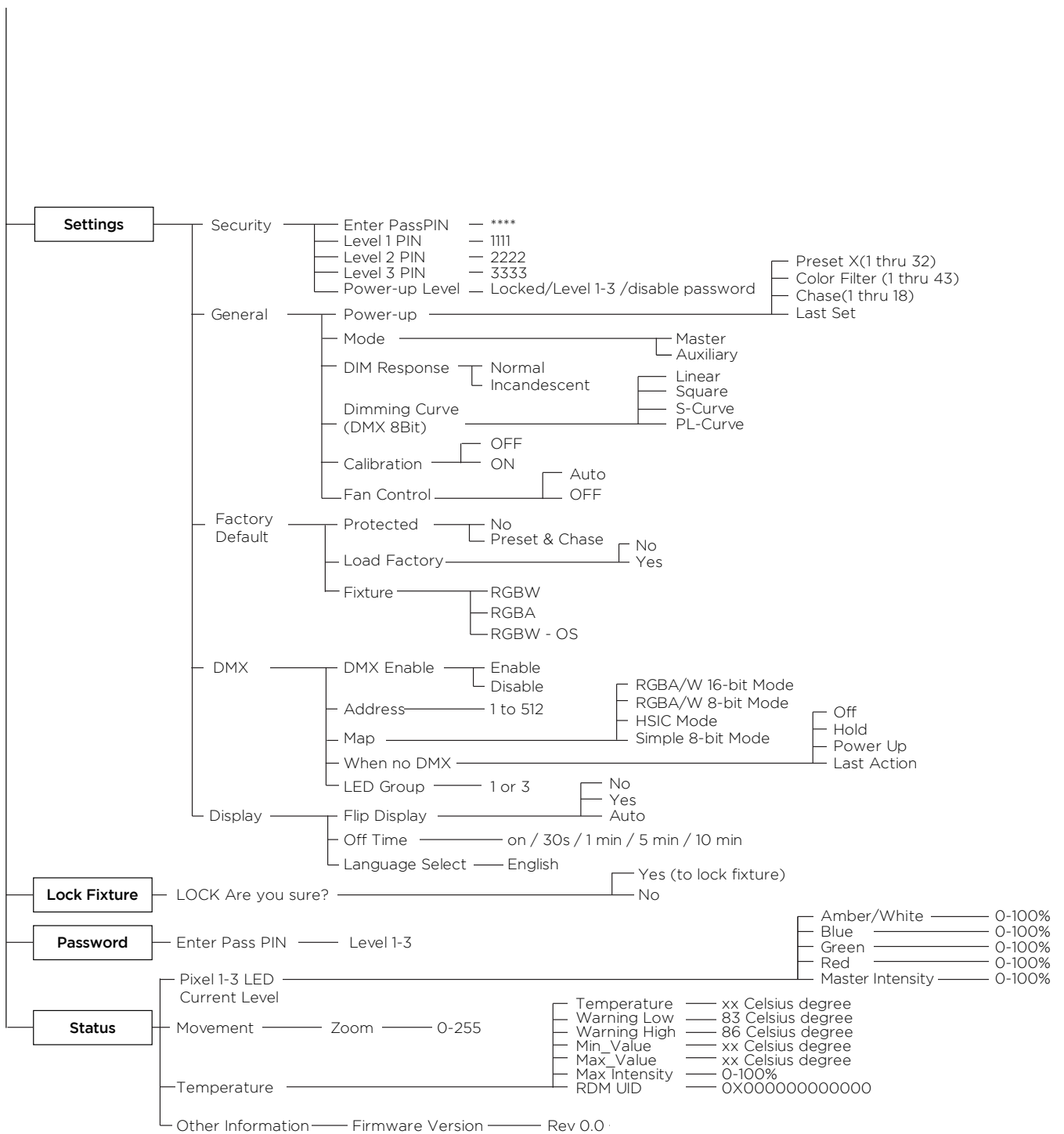

Figure 10: SL PUNCHLITE 220 Menu Tree(Part 2)

4. Quick Selection Buttons

When in Manual Mode, the SL PUNCHLITE 220's features can be accessed via the on-board LCD menu system or via three quick select buttons:

- Edit a Preset Button
- Edit a Chase Button
- DMX Address Button

Edit a Preset Button

To edit and save a preset:

- Step 1. Press Edit a Preset button. Current preset will be shown.
- Step 2. Use LEFT and RIGHT arrow buttons to scroll through all presets.
- Step 3. Once at desired preset, use UP and DOWN arrows to access (highlight) preset parameters. Once in desired parameter, use LEFT and RIGHT arrow buttons to adjust parameter value as desired.
- Step 4. Once all values are adjusted as desired, press OK (Check Mark) button.
- Step 5. Save preset menu option will appear. Use LEFT and RIGHT arrow buttons to select preset number.
- Step 6. If saving preset, press OK (Check Mark) button. Confirm choice.
- Step 7. Preset is now saved.

Edit a Preset

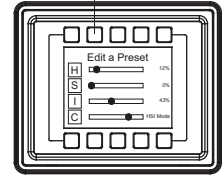

Edit a Chase Button

To edit and save a chase:

- Step 1. Press Edit a Chase button. Current chase will be shown.
- Step 2. Use LEFT and RIGHT arrow buttons to scroll through all chases (Built In and User Chases).

Edit a Chase

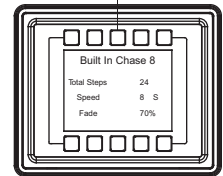

Note: For Built In Chases, only the Speed and Fade parameters may be changed and saved. For User Chases, Chase Number, Total Steps, Speed, and Fade Parameters may be changed and saved.

- Step 3. Once at desired chase, use UP and DOWN arrows to access (highlight) chase parameters. Once in desired parameter, use LEFT and RIGHT arrow buttons to adjust parameter value as desired.
- Step 4. Once all values are adjusted as desired, press OK (Check Mark) button.
- Step 5. Save chase menu option will appear. Use LEFT and RIGHT arrow buttons to select chase number.
- Step 6. If saving chase, press OK (Check Mark) button. Confirm choice.
- Step 7. Chase is now saved.

DMX Address Button

To edit and save a DMX address:

- Step 1. Press DMX Address button. Current DMX Address will be shown.
- Step 2. Press OK (Check Mark) button to highlight a digit in the DMX address.
- Step 3. Use LEFT and RIGHT arrow buttons to scroll through all digits.
- Step 4. Once at desired digit, use UP and DOWN arrows to change highlighted digit. Once digit is set, use LEFT and RIGHT arrow buttons to set other digits in DMX address.
- Step 5. Once all digits are set in DMX address, press OK (Check Mark) button.
- Step 6. DMX will display and is saved.

DMX Address

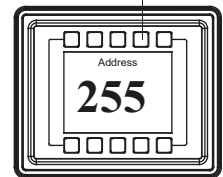

5. Dimming Curve Selection

Through the menu, you are able to select one of four dimming curves:

- Linear Curve
- PL_Curve
- S_Curve
- Square Curve

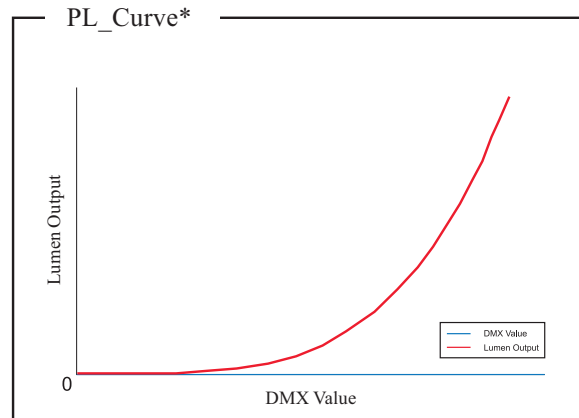
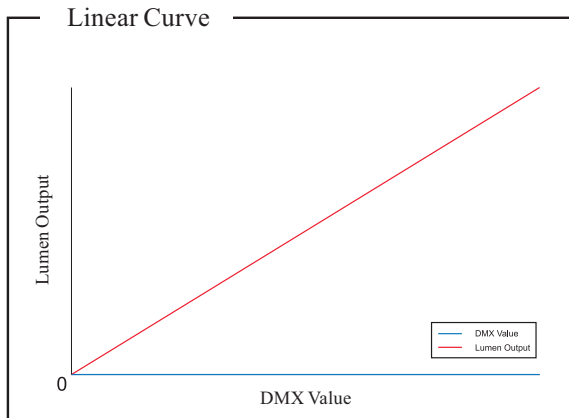

*PL Curve follows the dimming curve of Vari-Lite Selecon PL series LED luminaires.

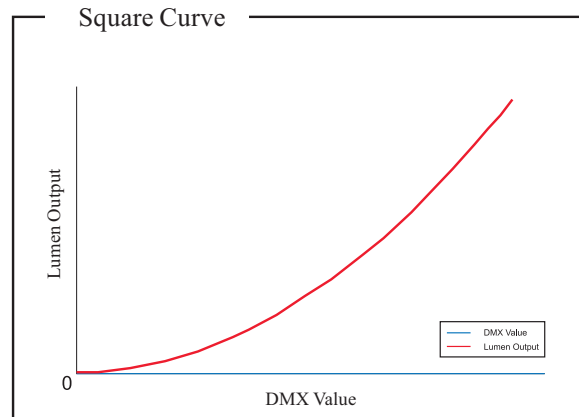
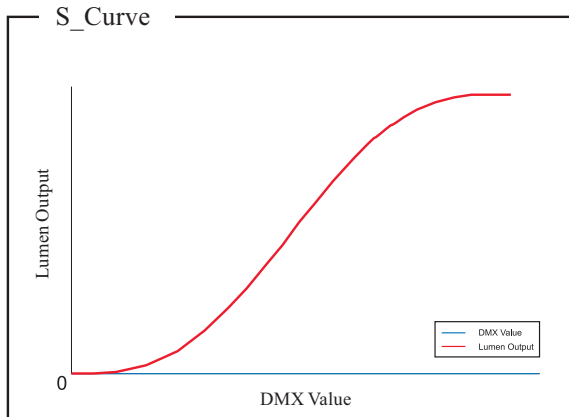

Figure 11: SL PUNCHLITE 220 Dimmer Curves

6. Primary/Auxiliary Operational Mode

The Primary/Auxiliary Operational Mode allows one SL PUNCHLITE 220 to act as the "Primary" luminaire and all other connected luminaires are controlled by this luminaire. When a luminaire is set to "auxiliary" mode, it will only listen to and follow any commands sent from a "Primary" luminaire. Only one "Primary" luminaire is allowed in this type of operation.

To setup a master/auxiliary network:

- Step 1. Set the first luminaire in the DMX512 chain to Primary Mode through the luminaire's menu system.
- Step 2. Set all other connected luminaires to Auxiliary Mode.
- Step 3. The master luminaire can be controlled via DMX512, RDM or through standalone operation (Self-contained network utilizing on-board effects). The auxiliary luminaires will mimic the master luminaire's operation in all cases.

Note: For more information on DMX512 networking and systems, refer to "[Additional Resources for DMX512](#)" on page 1. For SL PUNCHLITE 220 DMX Mapping, refer to "[DMX CONTROL](#)" on page 16.

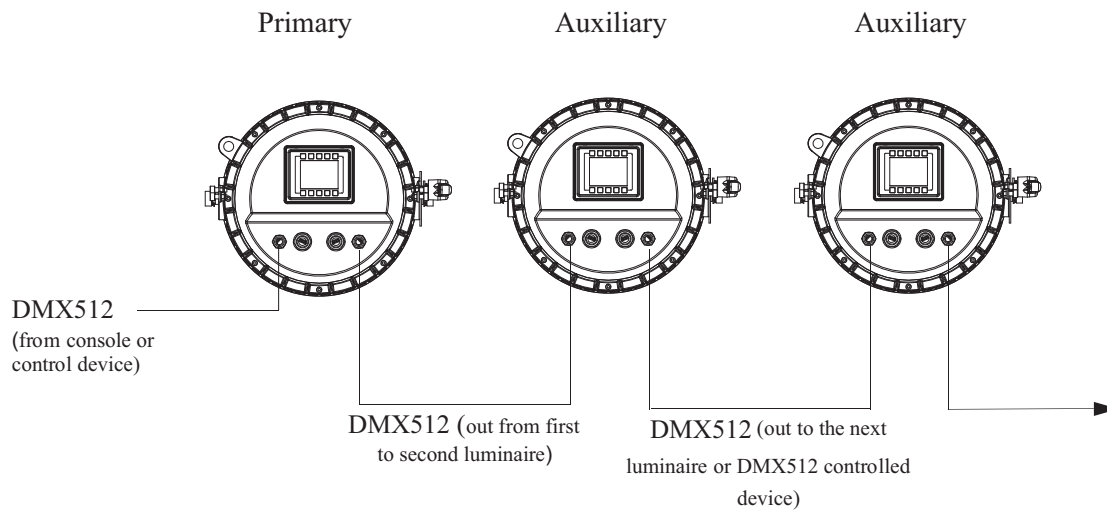

Figure 12: SL PUNCHLITE 220- Primary / Auxiliary Configuration

DMX CONTROL

This section contains information for operating the luminaire using DMX control in Simple 8-bit, RGBW 8-bit, RGBW 16-bit or HSIC (Hue, Saturation, Intensity and Color Correction) modes. For Menu options and detailed information, see "LCD Display and Menu System" on page 9.

Note: These tables assume a DMX start address of 1. When a different starting address is used, this address becomes channel 1 function and other functions follow in sequence.

1. SL PUNCHLITE 220 DMX Mapping

Simple 8-Bit Mode

Table 3 provides DMX channel mapping of all DMX512 control values when the SL PUNCHLITE 220 LED Luminaire is in simple 8-bit DMX512 mode (as set by the luminaire's menu system).

Table 3: SL PUNCHLITE 220 DMX Channel Mapping (Simple 8 - Bit Mode)

DMX Channel	Parameter	Range DMX	Range%	Default - recommended console default values	Description
1	Master Intensity	0-255	0-100%	0	8 bit control of Intensity of LED settings
2	Strobe	0-255	0-100%	0	Controls strobe operations as below Open DMX 0-2 Closed DMX 3-5 Slow Rand DMX 6-7 Med Rand DMX 8-10 Fast Rand DMX 11-12 Strobe Range DMX 13-127(fastest) Pulse + Slow Rand DMX 128-129 Pulse + Med Rand DMX 130-131 Pulse + Fast Rand DMX 132-133 Pulse + Range DMX 134-191 Pulse - Slow Rand DMX 192-193 Pulse - Med Rand DMX 194-195 Pulse - Fast Rand DMX 196-197 Pulse - Range DMX 198-255
3	Zoom	0-255	0-100%	0	Variable control of zoom from 8° - 40°
4	Control	0-255	0-100%	0	Functions of the SL Series products. Set control channel value to desired action, hold value for at least 5 seconds ,then turn to 0. Set control channel value to 0 without any scaling. Default Setting on Console = DMX 0-4 DIM Response_Normal = DMX 5 - 9 DIM Response_Incandescent = DMX 10 - 14 Dimming Curve_linear = DMX 30 - 34 Dimming Curve_Square = DMX 35- 39 Dimming Curve_S-Curve = DMX 40 - 44 Dimming Curve_PL-Curve = DMX 45 - 49 Calibration_OFF = DMX 70 - 74 Calibration_ON = DMX 75 - 79 Fan_Auto = DMX 80 - 84 Fan_Off = DMX 85 - 89 Reserves(Future use) = DMX 90 - 250
5	Red 1-3	0-255	0-100%	0	8 bit control of Red LEDs from 0 to full.
6	Green 1-3	0-255	0-100%	0	8 bit control of Green LEDs from 0 to full.
7	Blue 1-3	0-255	0-100%	0	8 bit control of Blue LEDs from 0 to full.
8	White/Amber 1-3	0-255	0-100%	0	8 bit control of White/Amber LEDs from 0 to full.

2. Simple 8-Bit Group Modes

Table 4 provides DMX channel mapping of all DMX512 control values when the SL PUNCHLITE 220 LED Luminaire is operated in various Simple 8-bit DMX512 Group Control Modes.

Table 4: SL PUNCHLITE 220 LED Luminaire DMX Channel Mapping (Simple 8-Bit Group Modes)

DMX CHANNEL	Simple 8 BIT MODE	
	3 Group MODE	1 Group MODE
1	Master Intensity	Master Intensity
2	Strobe	Strobe
3	Zoom	Zoom
4	Control	Control
5	Red_1	Red_1-3
6	Green_1	Green_1-3
7	Blue_1	Blue_1-3
8	White/Amber_1	White/Amber_1-3
9	Red_2	
10	Green_2	
11	Blue_2	
12	White/Amber_2	
13	Red_3	
14	Green_3	
15	Blue_3	
16	White/Amber_3	

3. RGBW/A 8 - Bit Mode

Table 5 provides DMX channel mapping of all DMX512 control values when the SL PUNCHLITE 220 LED Luminaire is in RGBW/A 8-bit DMX512 mode (as set by the luminaire's menu system).

Table 5: SL PUNCHLITE 220 DMX Channel Mapping (RGBW/A 8-Bit Mode)

DMX Channel	Parameter	Range DMX	Range%	Default - recommended console default values	Description
1	Master Intensity- High	0-255	0-100%	0	8 bit control for Intensity of LED settings.
2	Color Presets*	0-255	0-100%	0	Variable color Presets as follows... Channel OFF (disabled) DMX 0 - 4 Preset 0 (OFF) DMX 5 - 6 Preset 1 DMX 7 - 8 Preset 2 DMX 9 - 10 Preset 3 DMX 11 - 12 Preset 4 DMX 13 - 14 Preset 5 DMX 15 - 16 Preset 6 DMX 17 - 18 Preset 7 DMX 19 - 20 Preset 8 DMX 21 - 22 Preset 9 DMX 23 - 24 Preset 10 DMX 25 - 26 Preset 11 DMX 27 - 28 Preset 12 DMX 29 - 30 Preset 13 DMX 31 - 32 Preset 14 DMX 33 - 34 Preset 15 DMX 35 - 36 Preset 16 DMX 37 - 38 Preset 17 DMX 39 - 40 Preset 18 DMX 41 - 42 Preset 19 DMX 43 - 44 Preset 20 DMX 45 - 46 Preset 21 DMX 47 - 48 Preset 22 DMX 49 - 50 Preset 23 DMX 51 - 52 Preset 24 DMX 53 - 54 Preset 25 DMX 55 - 56 Preset 26 DMX 57 - 58 Preset 27 DMX 59 - 60 Preset 28 DMX 61 - 62 Preset 29 DMX 63 - 64 Preset 30 DMX 65 - 66 Preset 31 DMX 67 - 68 CF_0_Color OFF DMX 69 - 70 CF_1_White 10000K DMX 71 - 72 CF_2_White 8000K DMX 73 - 74 CF_3_White 6500K DMX 75 - 76 CF_4_White 5600K DMX 77 - 78 CF_5_White 5000K DMX 79 - 80 CF_6_White 4500K DMX 81 - 82 CF_7_White 4000K DMX 83 - 84 CF_8_White 3200K DMX 85 - 86 CF_9_White 3000K DMX 87 - 88 CF_10_White 2700K DMX 89 - 90
	*not available in RGBA model				

Table 5: SL PUNCLITE 220 DMX Channel Mapping (RGBW/A 8-Bit Mode)

DMX Channel	Parameter	Range DMX	Range%	Default - recommended console default values	Description	
2	Color Presets	0-255	0-100%	0	CF_11_Moroccan Pink	DMX 91 - 92
					CF_12_Pink	DMX 93 - 94
					CF_13_Flesh Pink	DMX 95 - 96
					CF_14_Bright Rose	DMX 97 - 98
					CF_15_Follies Pink	DMX 99 - 100
					CF_16_Fuchsia Pink	DMX 101 - 102
					CF_17_Surprise Pink	DMX 103 - 104
					CF_18_Congo Blue	DMX 105 - 106
					CF_19_Blue	DMX 107 - 108
					CF_20_Virgin Blue	DMX 109 - 110
					CF_21_Midnight Maya	DMX 111 - 112
					CF_22_Double C.T Blue	DMX 113 - 114
					CF_23_Slate Blue	DMX 115 - 116
					CF_24_Regal Blue	DMX 117 - 118
					CF_25_Full C.T Blue	DMX 119 - 120
					CF_26_Steel Blue	DMX 121 - 122
					CF_27_Lighter Blue	DMX 123 - 124
					CF_28_Cyan	DMX 125 - 126
					CF_29_Marine Blue	DMX 127 - 128
					CF_30_Soft Green	DMX 129 - 130
					CF_31_Moss Green	DMX 131 - 132
					CF_32_Green	DMX 133 - 134
					CF_33_Fem Green	DMX 135 - 136
					CF_34_JAS Green	DMX 137 - 138
					CF_35_Pale Green	DMX 139 - 140
					CF_36_Spring Yellow	DMX 141 - 142
					CF_37_Yellow	DMX 143 - 144
					CF_38_Deep Amber	DMX 145 - 146
					CF_39_Chrome Orange	DMX 147 - 148
					CF_40_Orange	DMX 149- 150
					CF_41_Magenta	DMX 151 - 152
					CF_42_Flame Red	DMX 153 - 154
					CF_43_Purple	DMX 155 - 156
					Rotate CW Fast → Slow	DMX 157 - 171
					Rotate ACW Slow → Fast	DMX 172 - 186
					Random Color Fast → Slow	DMX 187 - 201

Table 5: SL PUNCHLITE 220 DMX Channel Mapping (RGBW/A 8-Bit Mode)

DMX Channel	Parameter	Range DMX	Range%	Default - recommended console default values	Description
2	Color Presets	0-255	0-100%	0	Chase 1 DMX 202 - 204 Chase 2 DMX 205 - 207 Chase 3 DMX 208 - 210 Chase 4 DMX 211 - 213 Chase 5 DMX 214 - 216 Chase 6 DMX 217 - 219 Chase 7 DMX 220 - 222 Chase 8 DMX 223 - 225 Chase 9 DMX 226 - 228 Chase 10 DMX 229 - 231 User Chase 1 DMX 232 - 234 User Chase 2 DMX 235 - 237 User Chase 3 DMX 238 - 240 User Chase 4 DMX 241 - 243 User Chase 5 DMX 244 - 246 User Chase 6 DMX 247 - 249 User Chase 7 DMX 250 - 252 User Chase 8 DMX 253 - 255
3	Strobe	0 - 255	0 - 100%	0	Controls Strobe operations as follows... Open DMX 0 - 2 Closed DMX 3 - 5 Slow Rand DMX 6 - 7 Med Rand DMX 8 - 10 Fast Rand DMX 11 - 12 Strobe Range DMX 13 - 127 (faster) Pulse + Slow Rand DMX 128-129 Pulse + Med Rand DMX 130-131 Pulse + Fast Rand DMX 132-133 Pulse + Range DMX 134-191 Pulse - Slow Rand DMX 192-193 Pulse - Med Rand DMX 194-195 Pulse - Fast Rand DMX 196-197 Pulse - Range DMX 198-255
4	Duration	0 - 255	0 - 100%	0	Strobe's duration, Range is 0-85 0 DMX 0 1 DMX 1-3 x (DMX Value-1)/3+1 85 DMX 253-255

Table 5: SL PUNCHLITE 220 DMX Channel Mapping (RGBW/A 8-Bit Mode)

DMX Channel	Parameter	Range DMX	Range%	Default - recommended console default values	Description
5	Zoom	0 - 255	0 - 100%	255	Variable control of zoom from 8°– 40°
6	Timing	0 - 255	0 - 100%	255	Allows for timing control of intensity, color, and zoom parameters. Channel should default to 255 for smoothest actions using console and /or manual fades.- See Timing Chart for more details.
7	Control	0 - 255	0 - 100%	0	<p>Functions of the SL Series products. Set control channel value to desired action, hold value for at least 5 seconds ,then turn to 0.</p> <p>Set control channel value to 0 without any scaling.</p> <p>Default Setting on Console = DMX 0-4 DIM Response_Normal = DMX 5 - 9 DIM Response_Incandescent = DMX 10 - 14 Dimming Curve_linear = DMX 30 - 34 Dimming Curve_Square = DMX 35- 39 Dimming Curve_S-Curve = DMX 40 - 44 Dimming Curve_PL-Curve = DMX 45 - 49 Calibration_OFF = DMX 70 - 74 Calibration_ON = DMX 75 - 79 Fan_Auto = DMX 80 - 84 Fan_Off = DMX 85 - 89 Reserves(Future use) = DMX 90 - 250</p>
8	Red 1-3	0 - 255	0 - 100%	0	8 bit control of Red LEDs from 0 to full.
9	Green 1-3	0 - 255	0 - 100%	0	8 bit control of Green LEDs from 0 to full.
10	Blue 1-3	0 - 255	0 - 100%	0	8 bit control of Blue LEDs from 0 to full.
11	White/Amber 1-3	0 - 255	0 - 100%	0	8 bit control of White/Amber LEDs from 0 to full.

4. RGBW 8-Bit Group Modes

Table 6 provides DMX channel mapping of all DMX512 control values when the SL PUNCHLITE 220 LED Luminaire is operated in various RGBW 8-bit DMX512 Group Control Modes.

Table 6: SL PUNCHLITE 220 LED Luminaire DMX Channel Mapping (RGBW 8-Bit Group Modes)

RGBW 8 BIT MODE		
DMX CHANNEL	3 Group MODE	1 Group MODE
1	Master Intensity	Master Intensity
2	Color Presets	Color Presets
3	Strobe	Strobe
4	Duration	Duration
5	Zoom	Zoom
6	Timing	Timing
7	Control	Control
8	Red_1	Red_1-3
9	Green_1	Green_1-3
10	Blue_1	Blue_1-3
11	White/Amber_1	White/Amber_1-3
12	Red_2	
13	Green_2	
14	Blue_2	
15	White/Amber_2	
16	Red_3	
17	Green_3	
18	Blue_3	
19	White/Amber_3	

5. RGBW 16 - Bit Mode

Table 7 provides DMX channel mapping of all DMX512 control values when the SL PUNCHLITE 220 LED Luminaire is in RGBW/A 16-bit DMX512 mode (as set by the luminaire’s menu system).

Table 7: SL PUNCHLITE 220 DMX Channel Mapping (RGBW/A 16-Bit Mode)

DMX Channel	Parameter	Range DMX	Range%	Default - recommended console default values	Description
1	Master Intensity High	0 - 65535	0 - 100%	0	16 bit control for Intensity of LED settings.
2	Master Intensity Low				
3	Color Presets*	0 - 255	0 - 100%	0	Variable color Presets as follows... Channel OFF (disabled) DMX 0 - 4 Preset 0 (OFF) DMX 5 - 6 Preset 1 DMX 7 - 8 Preset 2 DMX 9 - 10 Preset 3 DMX 11 - 12 Preset 4 DMX 13 - 14 Preset 5 DMX 15 - 16 Preset 6 DMX 17 - 18 Preset 7 DMX 19 - 20 Preset 8 DMX 21 - 22 Preset 9 DMX 23 - 24 Preset 10 DMX 25 - 26 Preset 11 DMX 27 - 28 Preset 12 DMX 29 - 30 Preset 13 DMX 31 - 32 Preset 14 DMX 33 - 34 Preset 15 DMX 35 - 36 Preset 16 DMX 37 - 38 Preset 17 DMX 39 - 40 Preset 18 DMX 41 - 42 Preset 19 DMX 43 - 44 Preset 20 DMX 45 - 46 Preset 21 DMX 47 - 48 Preset 22 DMX 49 - 50 Preset 23 DMX 51 - 52 Preset 24 DMX 53 - 54 Preset 25 DMX 55 - 56 Preset 26 DMX 57 - 58 Preset 27 DMX 59 - 60 Preset 28 DMX 61 - 62 Preset 29 DMX 63 - 64 Preset 30 DMX 65 - 66 Preset 31 DMX 67 - 68 CF_0_Color OFF DMX 69 - 70 CF_1_White 1000K DMX 71 - 72 CF_2_White 8000K DMX 73 - 74 CF_3_White 6500K DMX 75 - 76 CF_4_White 5600K DMX 77 - 78 CF_5_White 5000K DMX 79 - 80 CF_6_White 4500K DMX 81 - 82 CF_7_White 4000K DMX 83 - 84 CF_8_White 3200K DMX 85 - 86 CF_9_White 3000K DMX 87 - 88 CF_10_White 2700K DMX 89 - 90
	*not available in RGBA model				

Table 7: SL PUNCLITE 220 DMX Channel Mapping (RGBW/A 16-Bit Mode)

DMX Channel	Parameter	Range DMX	Range%	Default - recommended console default values	Description	
3	Color Presets	0 - 255	0 - 100%	0	CF_11_Moroccan Pink	DMX 91 - 92
					CF_12_Pink	DMX 93 - 94
					CF_13_Flesh Pink	DMX 95 - 96
					CF_14_Bright Rose	DMX 97 - 98
					CF_15_Follies Pink	DMX 99 - 100
					CF_16_Fuchsia Pink	DMX 101 - 102
					CF_17_Surprise Pink	DMX 103 - 104
					CF_18_Congo Blue	DMX 105 - 106
					CF_19_Blue	DMX 107 - 108
					CF_20_Virgin Blue	DMX 109 - 110
					CF_21_Midnight Maya	DMX 111 - 112
					CF_22_Double C.T Blue	DMX 113 - 114
					CF_23_Slate Blue	DMX 115 - 116
					CF_24_Regal Blue	DMX 117 - 118
					CF_25_Full C.T Blue	DMX 119 - 120
					CF_26_Steel Blue	DMX 121 - 122
					CF_27_Lighter Blue	DMX 123 - 124
					CF_28_Cyan	DMX 125 - 126
					CF_29_Marine Blue	DMX 127 - 128
					CF_30_Soft Green	DMX 129 - 130
					CF_31_Moss Green	DMX 131 - 132
					CF_32_Green	DMX 133 - 134
					CF_33_Fem Green	DMX 135 - 136
					CF_34_JAS Green	DMX 137 - 138
					CF_35_Pale Green	DMX 139 - 140
					CF_36_Spring Yellow	DMX 141 - 142
					CF_37_Yellow	DMX 143 - 144
					CF_38_Deep Amber	DMX 145 - 146
					CF_39_Chrome Orange	DMX 147 - 148
					CF_40_Orange	DMX 149 - 150
					CF_41_Magenta	DMX 151 - 152
					CF_42_Flame Red	DMX 153 - 154
					CF_43_Purple	DMX 155 - 156
					Rotate CW Fast → Slow	DMX 157 - 171
					Rotate ACW Slow → Fast	DMX 172 - 186
					Random Color Fast → Slow	DMX 187 - 201

Table 7: SL PUNCLITE 220 DMX Channel Mapping (RGBW/A 16-Bit Mode)

DMX Channel	Parameter	Range DMX	Range%	Default - recommended console default values	Description
3	Color Presets	0-255	0-100%	0	Chase 1 DMX 202 - 204 Chase 2 DMX 205 - 207 Chase 3 DMX 208 - 210 Chase 4 DMX 211 - 213 Chase 5 DMX 214 - 216 Chase 6 DMX 217 - 219 Chase 7 DMX 220 - 222 Chase 8 DMX 223 - 225 Chase 9 DMX 226 - 228 Chase 10 DMX 229 - 231 User Chase 1 DMX 232 - 234 User Chase 2 DMX 235 - 237 User Chase 3 DMX 238 - 240 User Chase 4 DMX 241 - 243 User Chase 5 DMX 244 - 246 User Chase 6 DMX 247 - 249 User Chase 7 DMX 250 - 252 User Chase 8 DMX 253 - 255
4	Strobe	0 - 255	0 - 100%	0	Controls Strobe operations as follows... Open DMX 0 - 2 Closed DMX 3 - 5 Slow Rand DMX 6 - 7 Med Rand DMX 8 - 10 Fast Rand DMX 11 - 12 Strobe Range DMX 13 - 127 (faster) Pulse + Slow Rand DMX 128-129 Pulse + Med Rand DMX 130-131 Pulse + Fast Rand DMX 132-133 Pulse + Range DMX 134-191 Pulse - Slow Rand DMX 192-193 Pulse - Med Rand DMX 194-195 Pulse - Fast Rand DMX 196-197 Pulse - Range DMX 198-255
5	Duration	0 - 255	0 - 100%	0	Strobe's duration, Range is 0-85 0 DMX 0 1 DMX 1-3 x (DMX Value-1)/3+1 85 DMX 253-255

Table 7: SL PUNCLITE 220 DMX Channel Mapping (RGBW 16-Bit Mode)

DMX Channel	Parameter	Range DMX	Range%	Default - recommended console default values	Description
6	Zoom	0 - 255	0 - 100%	0	Variable control of zoom from 8° – 40°
7	Intensity Timing	0 - 255	0 - 100%	255	Allows for timing control of Intensity. Channel should default to 255 for smoothest actions using console and /or manual fades.
8	Color Timing	0 - 255	0 - 100%	255	Allows for timing control of colors. Channel should default to 255 for smoothest actions using console and / or manual fades.
9	Zoom Timing	0 - 255	0 - 100%	255	Allows for timing control of zoom.
10	Control	0 - 255	0 - 100%	0	<p>Functions of the SL Series products. Set control channel value to desired action, hold value for at least 5 seconds ,then turn to 0.</p> <p>Set control channel value to 0 without any scaling.</p> <p>Default Setting on Console = DMX 0-4</p> <p>DIM Response_Normal = DMX 5 - 9</p> <p>DIM Response_Incandescent = DMX 10 - 14</p> <p>Dimming Curve_linear = DMX 30 - 34</p> <p>Dimming Curve_Square = DMX 35- 39</p> <p>Dimming Curve_S-Curve = DMX 40 - 44</p> <p>Dimming Curve_PL-Curve = DMX 45 - 49</p> <p>Calibration_OFF = DMX 70 - 74</p> <p>Calibration_ON = DMX 75 - 79</p> <p>Fan_Auto = DMX 80 - 84</p> <p>Fan_Off = DMX 85 - 89</p> <p>Reserves(Future use) = DMX 90 - 250</p>
11	Red 1-3 High	0 - 65535	0 - 100%	0	16 bit control of Red LEDs from 0 to full.
12	Red 1-3 Low				
13	Green 1-3 High	0 - 65535	0 - 100%	0	16 bit control of Green LEDs from 0 to full.
14	Green 1-3 Low				
15	Blue 1-3 High	0 - 65535	0 - 100%	0	16 bit control of Blue LEDs from 0 to full.
16	Blue 1-3 Low				
17	White 1-3 High	0 - 65535	0 - 100%	0	16 bit control of White/Amber LEDs from 0 to full.
18	White/Amber 1-3 Low				

6. RGBW 16 - Bit Group Mode

Table 8 provides DMX channel mapping of all DMX512 control values when the SL PUNCHLITE 220 LED Luminaire is operated in various RGBW/A 16-bit DMX512 Group Control Modes.

Table 8: SL PUNCHLITE 220 LED Luminaire DMX Channel Mapping (RGBW/A 16-Bit Group Modes)

RGBW/A 16 BIT MODE		
DMX CHANNEL	3 Group MODE	1 Group MODE
1	Master Intensity - High	Master Intensity - High
2	Master Intensity - Low	Master Intensity - Low
3	Color Presets	Color Presets
4	Strobe	Strobe
5	Duration	Duration
6	Zoom	Zoom
7	Intensity Timing	Intensity Timing
8	Color Timing	Color Timing
9	Zoom Timing	Zoom Timing
10	Control	Control
11	Red_1 - High Byte	Red_1-3 - High Byte
12	Red_1 - Low Byte	Red_1-3 - Low Byte
13	Green_1 - High Byte	Green_1-3 - High Byte
14	Green_1 - Low Byte	Green_1-3 - Low Byte
15	Blue_1 - High Byte	Blue_1-3 - High Byte
16	Blue_1 - Low Byte	Blue_1-3 - Low Byte
17	White/Amber_1 - High Byte	White/Amber_1-3 - High Byte
18	White/Amber_1 - Low Byte	White/Amber_1-3 - Low Byte
19	Red_2 - High Byte	
20	Red_2 - Low Byte	
21	Green_2 - High Byte	
22	Green_2 - Low Byte	
23	Blue_2 - High Byte	
24	Blue_2 - Low Byte	
25	White/Amber_2 - High Byte	
26	White/Amber_2 - Low Byte	
27	Red_3 - High Byte	
28	Red_3 - Low Byte	
29	Green_3 - High Byte	
30	Green_3 - Low Byte	
31	Blue_3 - High Byte	
32	Blue_3 - Low Byte	
33	White/Amber_3 - High Byte	
34	White/Amber_3 - Low Byte	

7. HSIC Mode

Table 9 provides DMX channel mapping of all DMX512 control values when the SL PUNCHLITE 220 LED Luminaire is in HSIC (Hue, Saturation, Intensity, and Color Correction) DMX512 mode (as set by the luminaire's menu system).

Table 9: SL PUNCHLITE 220 DMX Channel Mapping (HSIC Mode)

DMX Channel	Parameter	Range DMX	Range%	Default - recommended console default values	Description
1	Master Intensity	0 - 255	0 - 100%	0	8 bit control for Intensity of LED settings.
2	Strobe	0 - 255	0 - 100%	0	Controls strobe operations as follows... Open DMX 0 - 2 Closed DMX 3 - 5 Slow Rand DMX 6 - 7 Med Rand DMX 8 - 10 Fast Rand DMX 11 - 12 Strobe Range DMX 13- 127 (faster) Pulse + Slow Rand = DMX 128-129 Pulse + Med Rand = DMX 130-131 Pulse + Fast Rand = DMX 132-133 Pulse + Range = DMX 134-191 Pulse - Slow Rand = DMX 192-193 Pulse - Med Rand = DMX 194-195 Pulse - Fast Rand = DMX 196-197 Pulse - Range = DMX 198-255
3	Duration	0 - 255	0 - 100%	0	Strobe's duration, Range is 0-85 0 = DMX 0 1 = DMX 1-3 x = (DMX Value-1)/3+1 85 = DMX 253-255
4	Zoom	0 - 255	0 - 100%	0	Variable control of zoom from 8° - 40°
5	Timing	0 - 255	0 - 100%	255	Allows for timing control of intensity, color, and zoom parameters. Channel should default to 255 for smoothest actions using console and /or manual fades.
6	Control	0 - 255	0 - 100%	0	Functions of the SL Series products. Set control channel value to desired action,hold value for at least 5 seconds, then turn to 0. Set control channel value to 0 without any scaling. Default Setting on console = DMX 0-4 DIM Response_Normal = DMX 5-9 DIM Response_Incandescent = DMX 10-14 Dimming Curve_linear = DMX 30-34 Dimming Curve_Square = DMX 35-39 Dimming Curve_S-Curve = DMX 40-44 Dimming Curve_PL-Curve = DMX 45-49 Calibration_OFF = DMX 70-74 Calibration_ON = DMX 75-79 Reserves(Future Use) = DMX 80-250
7	Hue 1-3 - High Byte	0 - 65535	0 - 100%	0	16 bit control of Hue 0 - 359°
8	Hue 1-3 - Low Byte				
9	Saturation 1-3	0 - 255	0 - 100%	0	8 bit control of Saturation
10	Intensity 1-3	0 - 255	0 - 100%	0	8 bit control of Intensity
11	CCT 1-3	0 - 255	0 - 100%	0	Variable control of correlated color temperature from Channel OFF (disabled) DMX 0-5 2700K - 6500K DMX 6 - 255

8. HSIC Group Modes

Table 10 provides DMX channel mapping of all DMX512 control values when the SL PUNCHLITE 220 LED Luminaire is operated in various HSIC DMX512 Group Control Modes.

Table 10: SL PUNCHLITE 220 LED Luminaire DMX Channel Mapping (HSIC Group Modes)

DMX CHANNEL	HSIC MODE	
	3 Group MODE	1 Group MODE
1	Master Intensity	Master Intensity
2	Strobe	Strobe
3	Duration	Duration
4	Zoom	Zoom
5	Timing	Timing
6	Control	Control
7	Hue_1 - High Byte	Hue_1-3 - High Byte
8	Hue_1 - Low Byte	Hue_1-3 - Low Byte
9	Saturation_1	Saturation_1-3
10	Intensity_1	Intensity_1-3
11	CCT_1	CCT_1-3
12	Hue_2 - High Byte	
13	Hue_2 - Low Byte	
14	Saturation_2	
15	Intensity_2	
16	CCT_2	
17	Hue_3 - High Byte	
18	Hue_3 - Low Byte	
19	Saturation_3	
20	Intensity_3	
21	CCT_3	

9. DMX Timing Channel Detail

Timing channel control improves the timed moves of certain groups of parameters. The SL PUNCHLITE 220 LED Luminaire provides timing channels in 16-bit mode (one for intensity time and one for color time) and one timing channel in 8-bit (color and intensity timing combined). The luminaire uses its timing channel value to calculate a smooth continuous operation for a given time and transition.

Guidelines:

- Timing channels support time values from zero to 60 minutes.
- To use a timing channel instead of console timing, it is recommended to set the timing channel to the desired value and set cue and/or console cue fade time to zero. A combination of time controls can produce unexpected results.
- The default value setting in the profile should be 255 (proportional control) to allow smooth operation when using console timing.
- The timing channel data should change as a snap. A zero value will give the fastest operation, however, without any smoothing this can appear "steppy" in console timed moves.

Refer to "[DMX Timing Channel Detail](#)" for more information.

Table 11: SL PUNCHLITE 220 Timing Channel Detail

% Value	DMX	= Seconds <i>(unless noted)</i>
0	0	0 (Full Speed)
	1	0.2
	2	0.4
1	3	0.6
	4	0.8
2	5	1
	6	1.2
	7	1.4
3	8	1.6

Table 11: SL PUNCLITE 220 Timing Channel Detail

% Value	DMX	= Seconds (unless noted)
	9	1.8
4	10	2
	11	2.2
	12	2.4
5	13	2.6
	14	2.8
6	15	3
	16	3.2
	17	3.4
7	18	3.6
	19	3.8
8	20	4
	21	4.2
	22	4.4
9	23	4.6
	24	4.8
10	25	5
	26	5.2
	27	5.4
11	28	5.6
	29	5.8
	30	6
12	31	6.2
	32	6.4
13	33	6.6
	34	6.8
	35	7
14	36	7.2
	37	7.4
15	38	7.6
	39	7.8
	40	8
16	41	8.2
	42	8.4
17	43	8.6
	44	8.8
	45	9
18	46	9.2
	47	9.4
19	48	9.6
	49	9.8
	50	10
20	51	10.2
	52	10.4
	53	10.6
21	54	10.8
	55	11
22	56	11.2
	57	11.4
	58	11.6
23	59	11.8

Table 11: SL PUNCHLITE 220 Timing Channel Detail

% Value	DMX	= Seconds (unless noted)
	60	12
24	61	12.2
	62	12.4
	63	12.6
25	64	12.8
	65	13
26	66	13.2
	67	13.4
	68	13.6
27	69	13.8
	70	14
28	71	14.2
	72	14.4
	73	14.6
29	74	14.8
	75	15
30	76	15.2
	77	15.4
	78	15.6
31	79	15.8
	80	16
	81	16.2
32	82	16.4
	83	16.6
33	84	16.8
	85	17
	86	17.2
34	87	17.4
	88	17.6
35	89	17.8
	90	18
	91	18.2
36	92	18.4
	93	18.6
37	94	18.6
	95	19
	96	19.2
38	97	19.4
	98	19.6
39	99	19.8
	100	20
	101	21
40	102	22
	103	23
	104	24
41	105	25
	106	26
42	107	27
	108	28
	109	29
43	110	30

Table 11: SL PUNCLITE 220 Timing Channel Detail

% Value	DMX	= Seconds (unless noted)
	111	31
44	112	32
	113	33
	114	34
45	115	35
	116	36
46	117	37
	118	38
	119	39
47	120	40
	121	41
48	122	42
	123	43
	124	44
49	125	45
	126	46
	127	47
50	128	48
	129	49
51	130	50
	131	51
	132	52
52	133	53
	134	54
53	135	55
	136	56
	137	57
54	138	58
	139	59
55	140	60
	141	61
	142	62
56	143	63
	144	64
57	145	65
	146	66
	147	67
58	148	68
	149	69
59	150	70
	151	71
	152	72
60	153	73
	154	74
	155	75
61	156	76
	157	77
62	158	78
	159	79
	160	80
63	161	81

Table 11: SL PUNCLITE 220 Timing Channel Detail

% Value	DMX	= Seconds (unless noted)
	162	82
64	163	83
	164	84
	165	85
65	166	86
	167	87
66	168	88
	169	89
	170	90
67	171	91
	172	92
68	173	93
	174	94
	175	95
69	176	96
	177	97
	178	98
70	179	99
	180	100
71	181	101
	182	102
	183	103
72	184	104
	185	105
73	186	106
	187	107
	188	108
74	189	109
	190	110
75	191	111
	192	112
	193	113
76	194	114
	195	115
77	196	116
	197	117
	198	118
78	199	119
	200	120
79	201	121
	202	122
	203	123
80	204	124
	205	125
81	206	126
	207	127
	208	128
82	209	129
	210	130
	211	131
83	212	132

Table 11: SL PUNCLITE 220 Timing Channel Detail

% Value	DMX	= Seconds (unless noted)
	213	133
84	214	134
	215	135
	216	136
85	217	137
	218	138
86	219	139
	220	140
	221	141
87	222	142
	223	143
88	224	144
	225	145
	226	146
89	227	147
	228	148
	229	149
90	230	150
	231	151
91	232	152
	233	153
	234	154
92	235	155
	236	156
93	237	157
	238	158
	239	159
94	240	160
	241	161
95	242	162
	243	163
	244	164
96	245	165
	246	5 Minutes
97	247	15 Minutes
	248	30 Minutes
	249	60 Minutes
98	250*	60mS
	251*	80mS
99	252*	100mS
	253*	120mS
	254*	140mS
100	255* (Default)	160mS

Note: DMX values 250 to 255 provide smoothing when using console fade timing. DMX value 255(recommended default) will provide the smoothest timing.

RDM PARAMETER IDS

1. SL PUNCHLITE 220 RDM Parameter IDs

The following tables outline and describe all the RDM parameters Ids associated with SL PUNCHLITE 220 LED Luminaires.

- Table 12, “SL PUNCHLITE 220 RDM Product Parameters IDs”
- Table 13, “SL PUNCHLITE 220 RDM UID”
- Table 14, “SL PUNCHLITE 220 RDM Parameters IDs”
- Table 15, “SL PUNCHLITE 220 RDM Manufacturer IDs” on page 38
- Table 16, “SL PUNCHLITE 220 RDM Manufacturer Specific PIDs” on page 38

Table 12: SL PUNCHLITE 220 RDM Product Parameters IDs

Model ID	Manufacturer	Model Description	Product Category
0x1210	Vari-Lite Asia	SL PAR 220 ZOOM	0x0509

Table 13: SL PUNCHLITE 220 RDM UID

UID					
MSB of ESTA 50H	LSB of ESTA 41H	1st of Unique Seq	2nd of Unique Seq	3rd of Unique Seq	4th of Unique Seq

Table 14: SL PUNCHLITE 220 RDM Parameters IDs

Get Allowed	Set Allowed	RDM Parameter IDs	Value	Comment	Implemented
<i>Category - Network Management</i>					
		DISC_UNIQUE_BRANCH	0x0001		■
		DISC_MUTE	0x0002		■
		DISC_UN_MUTE	0x0003		■
■		PROXIED_DEVICES	0x0010		
■		PROXIED_DEVICES_COUNT	0x0011		
■	■	COMMS_STATUS	0x0015		
<i>Category - Status Collection</i>					
■		QUEUED_MESSAGE	0x0020		■
■		STATUS_MESSAGES	0x0030		■
■		STATUS_ID_DESCRIPTION	0x0031		■
	■	CLEAR_STATUS_ID	0x0032		■
■	■	SUB_DEVICE_STATUS_REPORT_THRESHOLD	0x0033		
<i>Category - RDM Information</i>					
■		SUPPORTED_PARAMETERS	0x0050	Support required only if supporting Parameters beyond the minimum required set.	■
■		PARAMETER_DESCRIPTION	0x0051	Support required for Manufacturer-Specific PIDs exposed in SUPPORTED_PARAMETERS message.	■

Table 14: SL PUNCLITE 220 RDM Parameters IDs

Get Allowed	Set Allowed	RDM Parameter IDs	Value	Comment	Implemented
<i>Category - Product Information</i>					
■		DEVICE_INFO	0x0060		■
■		PRODUCT_DETAIL_ID_LIST	0x0070		
■		DEVICE_MODEL_DESCRIPTION	0x0080		■
■		MANUFACTURER_LABEL	0x0081		■
■	■	DEVICE_LABEL	0x0082		■
■	■	FACTORY_DEFAULTS	0x0090		■
■		LANGUAGE_CAPABILITIES	0x00A0		
■	■	LANGUAGE	0x00B0		
■		SOFTWARE_VERSION_LABEL	0x00C0		■
■		BOOT_SOFTWARE_VERSION_ID	0x00C1		
■		BOOT_SOFTWARE_VERSION_LABEL	0x00C2		
<i>Category - DMX512 Setup</i>					
■	■	DMX_PERSONALITY	0x00E0		■
■		DMX_PERSONALITY_DESCRIPTION	0x00E1		■
■	■	DMX_START_ADDRESS	0x00F0	Required if device uses a DMX Slot	■
■		SLOT_INFO	0x0120		■
■		SLOT_DESCRIPTION	0x0121		■
■		DEFAULT_SLOT_VALUE	0x0122		
<i>Category - Sensors 0x02xx</i>					
■		SENSOR_DEFINITION	0x0200		■
■	■	SENSOR_VALUE	0x0201		■
	■	RECORD_SENSORS	0x0202		
<i>Category - Dimmer Settings 0x03xx - FUTURE USE</i>					
<i>Category - Power / Lamp Settings 0x04xx</i>					
■	■	DEVICE_HOURS	0x0400		
■	■	LAMP_HOURS	0x0401		
■	■	LAMP_STRIKES	0x0402		
■	■	LAMP_STATE	0x0403		
■	■	LAMP_ON_MODE	0x0404		
■	■	DEVICE_POWER_CYCLES	0x0405		
<i>Category - Display Settings 0x05xx</i>					
■	■	DISPLAY_INVERT	0x0500		■
■	■	DISPLAY_LEVEL	0x0501		
<i>Category - Configuration 0x06xx</i>					
■	■	PAN_INVERT	0x0600		
■	■	TILT_INVERT	0x0601		
■	■	PAN_TILT_SWAP	0x0602		
■	■	REAL_TIME_CLOCK	0x0603		
<i>Category - Control 0x10xx</i>					
■	■	IDENTIFY_DEVICE	0x1000		■
	■	RESET_DEVICE	0x1001		

Table 14: SL PUNCHLITE 220 RDM Parameters IDs

Get Allowed	Set Allowed	RDM Parameter IDs	Value	Comment	Implemented
■	■	POWER_STATE	0x1010		
■	■	PERFORM_SELFTEST	0x1020		
■		SELF_TEST_DESCRIPTION	0x1021		
	■	CAPTURE_PRESET	0x1030		
■	■	PRESET_PLAYBACK	0x1031		

Table 15: SL PUNCHLITE 220 RDM Parameter Status IDs

Manufacturer Specific messages are in the range of 0x8000 - 0xFFDF. Each Manufacturer-specific Status ID shall have a unique meaning, which shall be consistent across all products having a given Manufacturer ID. See Table B-2, ANSI E1.20-2010

Status ID Message	Value	Data Value 1	Data Value 2	Status ID Description
8100H		00H	00H	ALL OK

Table 16: SL PUNCHLITE 220 RDM Parameter Specific PIDs

Get Allowed	Set Allowed	RDM Parameter IDs	Type	Length	Unit	Prefix	Min	Max	Default	Description
<i>Category - Manufacturer Defined PIDs - Range is 0x80000-0xffdf(See ANSI E1.20-2010 Standard, Table A-3)</i>										
■	■	8A00H	U8	1	NONE	NONE	0	100	100	DIMMER
■	■	8A04H	U8	1	NONE	NONE	0	100	100	Dimmer RED
■	■	8A05H	U8	1	NONE	NONE	0	100	100	Dimmer GREEN
■	■	8A06H	U8	1	NONE	NONE	0	100	100	Dimmer BLUE
■	■	8A07H	U8	1	NONE	NONE	0	100	100	Dimmer WHITE
■	■	8AB2H	U8	1	NONE	NONE	1	18	1	Chase
■	■	8AB0H	U8	1	NONE	NONE	0	43	0	Color Filter
■	■	8AB1H	U8	1	NONE	NONE	0	31	0	Preset
■	■	8A92H	U8	1	NONE	NONE	0	255	0	Strobe
■	■	8A94H	U8	1	NONE	NONE	0	85	0	Duration
■	■	8AC0H	U8	1	NONE	NONE	0	255	255	Intensity Timing
■	■	8AC2H	U8	1	NONE	NONE	0	255	255	Color Timing
■	■	8A40H	U8	1	NONE	NONE	0	1	0	Link Mode
■	■	8A42H	U8	1	NONE	NONE	0	1	0	Incandescent Effect
■	■	8AA1H	U8	1	NONE	NONE	0	3	0	Dimming Curve
■	■	8A0CH	U8	1	NONE	NONE	0	3	0	DMX FAIL MODE
■	■	8AA0H	U8	1	NONE	NONE	0	4	0	Backlight off time
■	■	8AA2H	U8	1	NONE	NONE	0	94	0	Power Up Setup
■	■	8A44H	U8	1	NONE	NONE	0	1	0	Calibration ON/OFF Setup
■	■	8A41H	U8	1	NONE	NONE	0	1	0	Lock Fixture
■	■	8A93H	U8	1	NONE	NONE	0	255	0	ZOOM

CLEANING AND CARE



WARNING! All cleaning should be performed with power completely removed from the luminaire. Never remove protective covers when luminaire is powered. Wear appropriate protective eye wear and gloves when cleaning the fixture. All service and maintenance, other than described herein, should be performed by a qualified technician or Authorized Service Center.

1. Special Cleaning and Care Instructions

Being a solid-state fixture, and unlike most fixtures, the SL PUNCHLITE 220 requires very little routine maintenance by the user. This section covers portions of the luminaire that can be removed for cleaning.

Take special care when it comes to cleaning the front lens cover. Additional care needs to be taken with the plastic components because they are much easier to scratch or damage than glass.

- Lint free lens tissue
- Lint or powder free gloves
- Reagent grade isopropyl alcohol*
- A mild soap solution

Note: *Reagent grade isopropyl alcohol is good to use on the SL PUNCHLITE 220 plastic optics with anti-reflection coatings.

If the front lens cover is still dirty after using isopropyl alcohol, for instance if fingerprints or oil is just redistributed and not cleaned off the optic, then a mild soap and water solution can be used to gently wash the lens. Repeat the cleaning with isopropyl alcohol to eliminate streaks and soap residue.



WARNING! Under no circumstances should ammonia-based cleaners, acetone, or other harsh solvents be used on or near the SL PUNCHLITE 220. These types of cleaners or solvents can permanently damage the optics or housings of the fixture.

If you have any questions regarding the use or care of your SL PUNCHLITE 220, please contact Showline technical support or your local Authorized Dealer.

2. Front Lens Cleaning

To clean the front lens:

- Step 1. Turn Off luminaire and allow to cool completely.
- Step 2. Apply a small amount of reagent grade isopropyl alcohol to lint-free lens tissue.
- Step 3. Wipe all debris, dirt, fingerprints, etc. from lens.
- Step 4. Using a second lint-free lens tissue, wipe off any alcohol residue.

3. Service and Maintenance

For all other service and maintenance issues, please contact your local Showline office or an Authorized Service Center.



WARNING! Disassembly (other than as described herein), alterations, unauthorized service, etc. will void the product warranty. Contact your local Showline office or an Authorized Service Center for technical support and service.

TECHNICAL SPECIFICATIONS

1. OPERATIONAL SPECIFICATIONS

Source:	18pcs Osram Olson RGBW/RGBA LED Array
Beam Angle:	8-40 Degrees
Light Output:	3500 lm with diffuser
Color Temperature:	2700 - 6500K (user adjustable)
Input Voltage:	100V to 240V(+/- 10%, auto-ranging)
Power Consumption:	220 Watts(max).
Frequency:	50/60Hz
Control Protocols:	DMX512(1990) / DMX512A (RDM) / On-Board Menu
Ambient Temperature:	-20 to 40 Degrees C (-4 to 104 Degrees F)
Humidity:	5%-95% Non condensing
Cooling:	Silent passive cooling
Weight:	23.01 lbs(10.4 kg) - Luminaire only (no mount, AC input cable or accessories)
Housing:	Die Cast aluminium with Powder Coating
Compliance:	CB, cETL, C-Tick, FCC and CE Marked (International models)
IP Rating:	IP65

Note: Common model specifications shown. For specific model specifications, features, and accessories, refer to the product specification sheet for more details.



2. Luminaire Dimensions

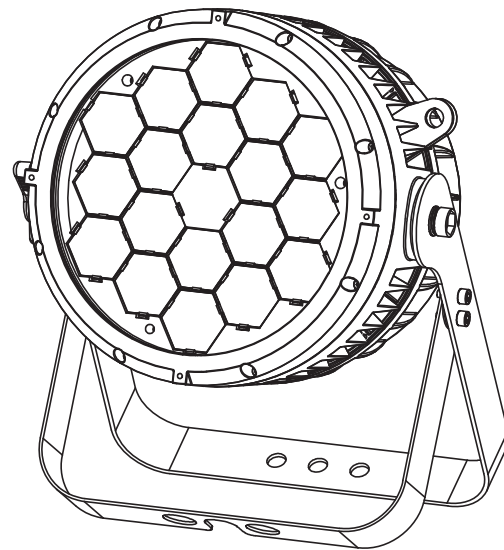
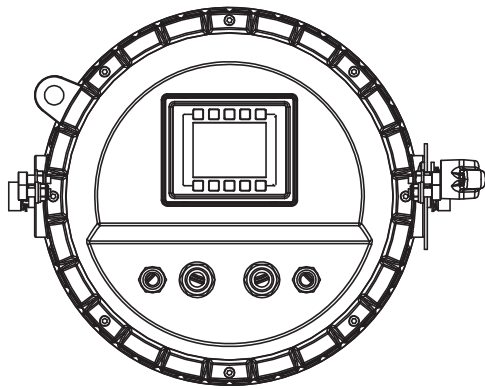
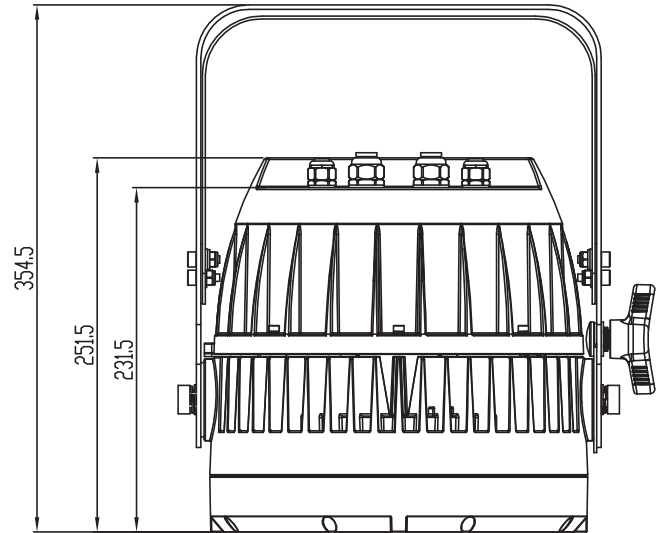
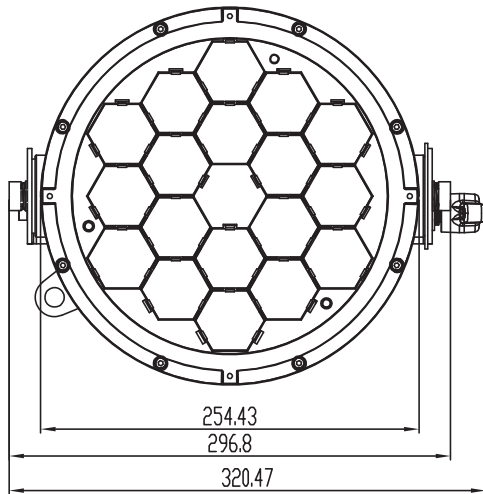

AMERICAS

10911 Petal Street
Dallas, TX 75235
Tel: +1 214-647-7880
Fax: +1 214-647-8039

ASIA

Unit C, 14/F, Roxy Industry Centre
41-49 Kwai Cheong Road
Kwai Chung, Kwai Tsing
Hong Kong
Tel: +852 2796 9786
Fax: +852 2798 6546

Room 1201, Freetown Tower D
E 3rd Ring Rd S, 58
Chaoyang Qu
Beijing Shi, China
Tel: +8610-58674776
Fax: +8610-58674775

B-1-27, Dataran Cascades, No. 13A
Jalan PJU 5/1
Kota Damansara PJU 5
47810 Petaling Jaya
Selangor, Malaysia
Tel: +60 3-7611 7302
Fax: +60 3-7629 4192

EUROPE

Rondweg Zuid 85
Winterswijk 7102 JD
Netherlands
Tel: +31 543-542516
Fax: +31 543-542513

24 Sovereign Park
Coronation Road
Park Royal, London
NW10 7QP
United Kingdom
Tel: +44 020 8965 3209

OCEANIA

14H Vega Place
Rosedale
Auckland 0632
New Zealand
Tel: +64 9-481-0100



© 2020 Signify Holding. All rights reserved.

All trademarks are owned by Signify Holding or their respective owners. The information provided herein is subject to change, without notice. Signify does not give any representation or warranty as to the accuracy or completeness of the information included herein and shall not be liable for any action in reliance thereon. The information presented in this document is not intended as any commercial offer and does not form part of any quotation or contract, unless otherwise agreed by Signify. Data subject to change.

SL PUNCHLITE 220 INSTALLATION & USER MANUAL
DOCUMENT NUMBER: 24-004-3736-04
VERSION DATE: SEPTEMBER 23 2020