

VISION.NET TOUCHSCREEN

OVERVIEW

This document provides installation and operation instructions for the following product(s):

| PRODUCT NAME | ORDER CODE |
|---|--|
| 10.1 inch Touchscreen assembly, compatible with Desktop Stand, 19" rack plate, flush or surface mount box accessories. For custom applications use with 10.1707.0501. | 95610 |
| Desktop stand portable | 95622 |
| 4U 19" rack plate with mounting bezel | 95623 |
| Flush mounting box with mounting bezel | 66824 |
| Surface mounting box with mounting bezel | 66825 |
| Locking cover | 66830 |
| ACCESSORIES | |
| Mounting bezel (optional for custom applications) | 10.1707.0501 |
| Vision.net touchscreen processor electronics box (for use with external monitor) | 95631 |
| COMPATIBLE MONITORS | |
| 15" monitor Required 7U rack plate | ELO E3317992 10.1707.0113 |
| 24" monitor | DELL P2418HT PLANAR PCT2435 |

INSTALLATION AND SET UP

POWER REQUIREMENTS

Vision.net Touchscreen operates on 24VDC. It is powered through the Touchscreen control PCB (pre-installed on the back of the touchscreen) via an external AC to DC power supply. It may alternatively be powered from a PoE+ (IEEE802.3at) compliant supply, using the RJ45 ethernet connector.

MOUNTING / INSTALLATION

To mount the touchscreen:

- Step 1. For surface and flush mount options, install the back box in the required location.
- Step 2. Fix the bezel in place, using the two supplied screws in position A (the screws are over length to accommodate varying thicknesses when flush mounting)
- Step 3. Connect the required cables to the screen connectors (see "Connecting Power" on page 3).
- Step 4. Mount the touchscreen by inserting the screen assembly into the bezel. Spring tabs on the touchscreen click into slots "B" on the bezel, securing the touchscreen.

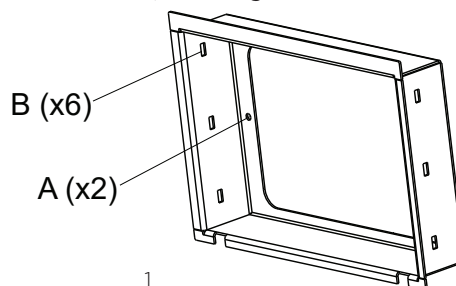

VISION.NET TOUCHSCREEN

To remove the touchscreen:

Step 1. Insert a nylon spudger (or other similar nylon pry tool) into one of the two slots at the bottom of the installed touchscreen.



WARNING: Do not use a metal screwdriver or any other metal pry tool to remove the touchscreen. Metal can scratch or crack the surface.

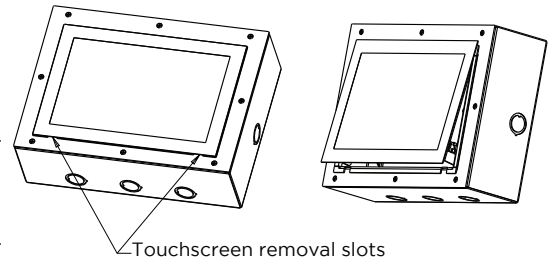

Step 2. Gently pry the bottom edge of the touchscreen module free of the frame and the internal snaps. Repeat the procedure at the second slot as needed. Remove touchscreen from the frame by gently pulling with finger tips.

Surface Mount

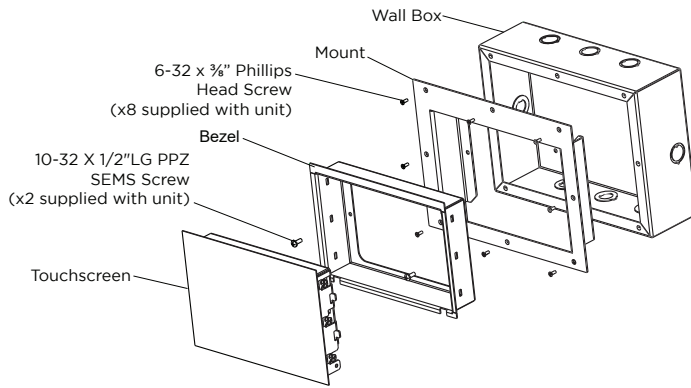

NOTES

- Total depth: 97mm (3.81")
- Size: 222mm x 301mm (8.73" x 11.85")
- Three knock outs on top and bottom, one knockout per side for 13mm (1/2") conduit (by others)
- Optional locking cover is installed between wall and bezel

Flush Mount

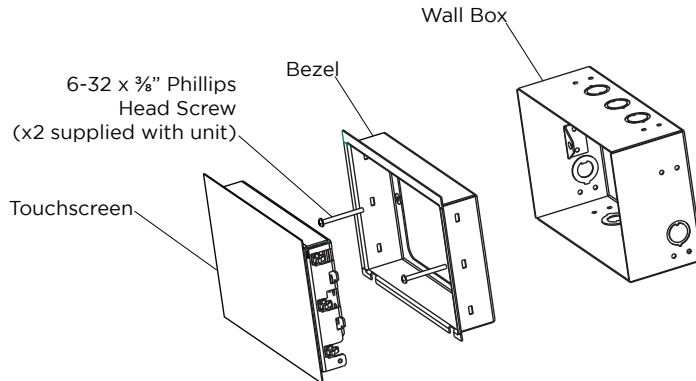

NOTES

- Rough opening: 248mm x 162mm (9.75" x 6.38") (cut/frame opening to this size)
- Depth extending out from wall: 2.54mm (0.10")
- Depth from surface of wall: 92mm (3.63")
- Size: 175mm x 256mm (6.89" x 10.09")
- Three knock outs on top and bottom, one knockout per side for 13mm (1/2") conduit (by others)
- Touchscreen is inserted and snapped securely into place
- Optional locking cover is installed between wall and bezel

Rack Mount

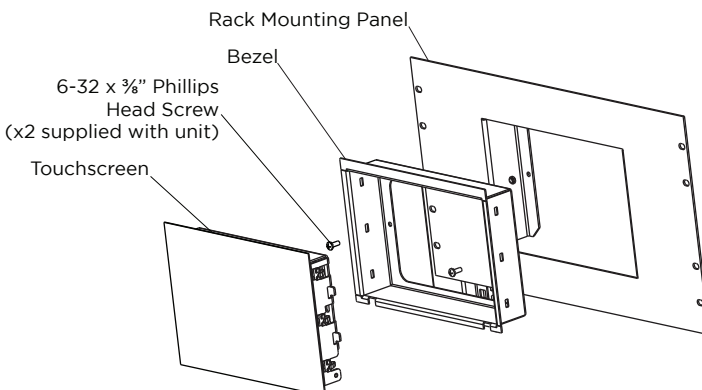

NOTES

- Depth from back of panel: 53mm (2.07")
- Size including panel: 264mm x 481mm (10.41" x 18.94")
- Size of locking face plate: 242mm x 301mm (9.51" x 11.85")
- Touchscreen is inserted and snapped securely into place
- Optional locking cover is installed between rack mounting panel and bezel

VISION.NET TOUCHSCREEN

Portable Mount

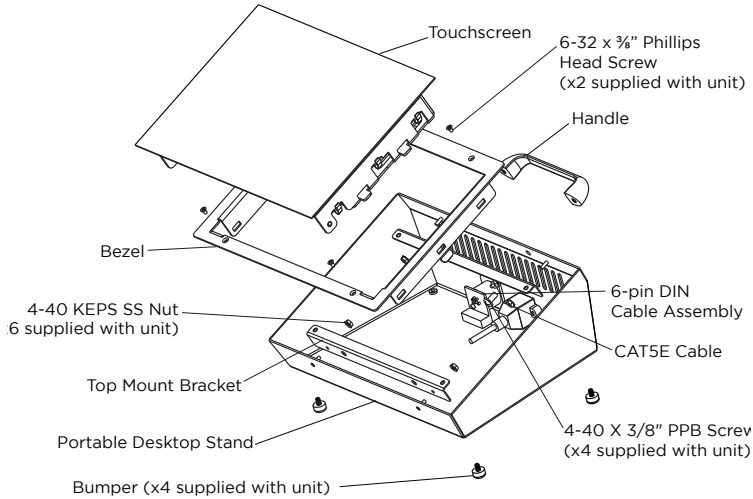

NOTES

- Total height: 105mm (4.12")
- Size including handle: 198mm x 264mm (7.81" x 10.4")
- No locking cover option

WIRING AND CONNECTIONS

VISION.NET WIRING CONNECTIONS

| PIN | SIGNAL | COLOR |
|-----|----------|----------------|
| 1 | Data+ | White / Orange |
| 2 | Data- | Orange |
| 3 | Not Used | Not Used |
| 4 | +NET V | White / Green |
| 5 | -NET V | Green |
| 6 | +NET V | White / Blue |
| 7 | -NET V | Blue |
| 8 | +NET V | White / Brown |
| 9 | -NET V | Brown |

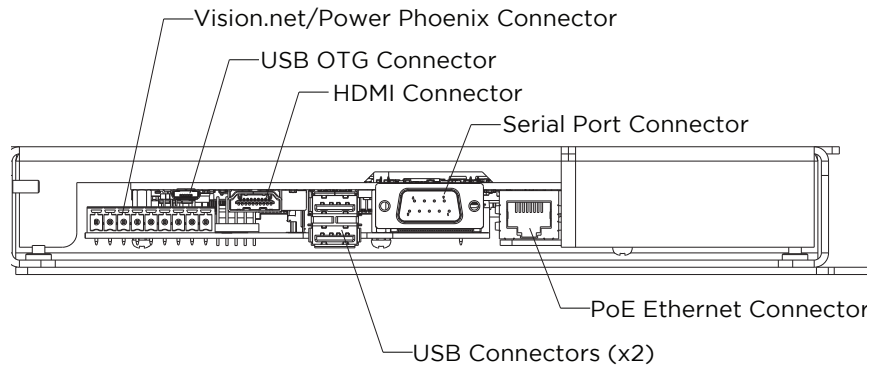

CONNECTING POWER

To connect an external power supply from Vision.net network:

- Step 1. Make sure power is disconnected (removed) before connecting power to touchscreen.
- Step 2. Consult wiring diagram and connect to Vision.net/Power Phoenix connector.

To connect an external power supply using PoE+ injector:

- Step 1. Make sure power is disconnected (removed) before connecting power to touchscreen.
- Step 2. Make PoE+ connection.

NETWORK CONNECTIONS

If you are not using PoE+, connect a standard CAT5e cable from the TCP/IP network directly to the RJ-45 port on the touchscreen. If the ethernet jack is used, a static IP address in the same range must be configured for the jack to be active.

VISION.NET TOUCHSCREEN

IMPORTANT INFORMATION

WARNINGS AND NOTICES

When using electrical equipment, basic safety precautions should always be followed including the following: READ AND FOLLOW ALL SAFETY INSTRUCTIONS.

- For indoor, dry locations use only. Do not use outdoors.
- Do not mount near gas or electric heaters.
- Equipment should be mounted in locations and at heights where it will not readily be subjected to tampering by unauthorized personnel.
- The use of accessory equipment not recommended by the manufacturer may cause an unsafe condition.
- Not for residential use. Do not use this equipment for other than intended use.
- Refer service to qualified personnel.



SAVE THESE INSTRUCTIONS.



WARNING: You must have access to a main circuit breaker or other power disconnect device before installing any wiring. Be sure that power is disconnected by removing fuses or turning the main circuit breaker off before installation. Installing the device with power on may expose you to dangerous voltages and damage the device. A qualified electrician must perform this installation.



WARNING: Refer to National Electrical Code® and local codes for cable specifications. Failure to use proper cable can result in damage to equipment or danger to personnel.



WARNING: This equipment is intended for installation in accordance with the National Electric Code® and local regulations. It is also intended for installation in indoor applications only. Before any electrical work is performed, disconnect power at the circuit breaker or remove the fuse to avoid shock or damage to the control. It is recommended that a qualified electrician perform this installation.

CUSTOMER SERVICE

If you have any questions regarding this product, please contact Customer Service at +1-214-647-7880 or via e-mail at entertainment.service@signify.

LIMITED 2-YEAR WARRANTY

Strand offers a two-year limited warranty on its control products against defects in materials or workmanship from the date of delivery. A copy of Strand two-year limited warranty containing specific terms and conditions can be obtained from the Strand web site at www.strandlighting.com or by contacting your local Strand office.

©2019 Signify Holding. All rights reserved.

All trademarks are owned by Signify Holding or their respective owners. The information provided herein is subject to change, without notice. Signify does not give any representation or warranty as to the accuracy or completeness of the information included herein and shall not be liable for any action in reliance thereon. The information presented in this document is not intended as any commercial offer and does not form part of any quotation or contract, unless otherwise agreed by Signify. Data subject to change.