



VARI\***LITE**

# VL800 EVENTWASH

USER MANUAL

# PREFACE

---

## 1. ABOUT THIS MANUAL

The document provides installation and operation instructions for the following product(s):

- VL800 EVENTWASH

Read all instructions before installing or using this product. Retain this manual for future reference.

## 2. INCLUDED ITEMS

Each VL800 EVENTWASH luminaire includes the following items:

- VL800 EVENTWASH
- Quick Start Guide

## 3. SAFETY NOTICES

- Unpack and check carefully for shipping damage before using the fixture.
- Installation and operation only to be performed by trained personnel.
- Use safety tether for mounting.
- Install only in locations with adequate ventilation. There must be at least 50cm (20 in) clearance between the fixture and adjacent surfaces.
- To prevent overheating, ensure sure that air can flow freely from ventilation .
- Prior to operation, ensure that the voltage and frequency of the power supply match the power requirements of the unit.
- To minimize the risk of electric shock, ground the yellow/green conductor.
- Do not operate outside the ambient temperature range of 0-40°C.
- Do not connect the device to any dimmer pack.
- Upon first run, there may be smoke or smells. These will disappear after a few minutes of operation.
- Do not place flammable materials near the fixture.
- Inspect power cables and replace any damaged cables before each use.
- During operation, surface temperature of the fixture can reach up to 65°C. DO NOT touch the housing of the fixture.
- When not in use, turn fixture off to avoid shortening lifespan.
- Do not operate in dirty or dusty environment. Clean fixture regularly.
- Do not allow children to operate the fixture.
- Do not touch cables while the fixture is operation as there might be a hazard of electric shock.
- Avoid power wires together around other cables.
- In the event of serious operating problem, stop using the unit immediately.
- Never turn on and off the unit time after time.
- Regularly Inspect housing, lenses, ultraviolet filter, and cables. These items must be replaced if they are visibly damaged.
- Do not open the fixture as there are no user serviceable parts inside. Never attempt to repair the unit by yourself. Repairs carried out by unskilled people can lead to damage or malfunction. Please contact the nearest Authorized Service Center.
- Disconnect the mains power if the fixture is not used for a long time.
- Do use original packing materials once transport it again.
- To prevent or reduce the risk of electrical shock or fire, do not expose the unit to rain or moisture.
- Do not look directly at LED light beam.

# INSTALLATION AND SETUP

## 1. MOUNTING

The unit should be mounted via its screw holes on the bracket. Always ensure that the unit is firmly fixed to avoid vibration and slipping while operating. Always ensure that the structure to which you are attaching the unit is secure and is able to support a weight of 10 times of the unit's weight. Also always use a safety cable that can hold 12 times of the weight of the unit when installing the fixture.

The equipment must be installed by professionals. It must be installed at a place where is out of reach of people and has no one pass by or under it.

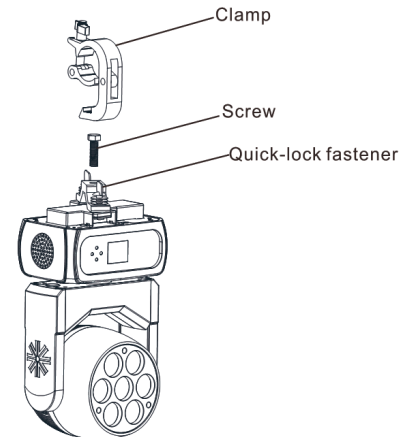

## 2. SET UP

### CONTROL PANEL

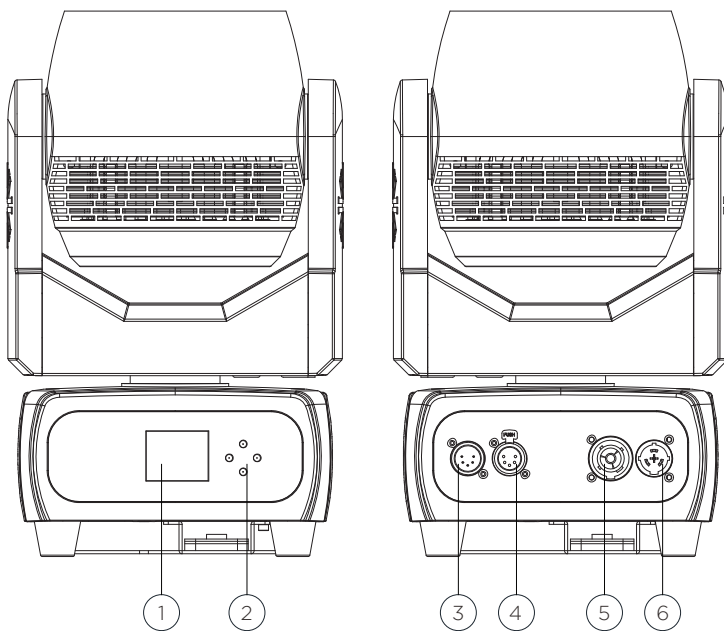

- ① LCD display - shows the menu and selected functions
- ② Buttons:  
MENU - To select the programming functions  
DOWN - To go backward in the selected functions  
UP - To go forward in the selected functions  
ENTER - To confirm the selected functions
- ③ DMX IN - 5-pin XLR cable to link DMX console
- ④ DMX OUT - 5-pin XLR cable to link to the next unit
- ⑤ Power In - connects to power supply
- ⑥ Power Out - connects to next fixture

### MAIN FUNCTIONS

To select any functions, press the MENU button until the required one is shown on the display. Select the function by the ENTER button and the display will blink. Use the DOWN and UP button to change the mode. Once the required mode has been selected, press the ENTER button to setup or it will automatically return to the main functions without any change after idling one minute. Back to the functions without any change press the MENU button. The main functions are shown in [TABLE 1](#).

TABLE 1. MENU FUNCTIONS						
LEVEL 1	LEVEL 2	LEVEL 3	LEVEL 4	LEVEL 5	LEVEL 6	DEFAULT
Address	000-512					(Default 001)
Configure	LED	LED Hours	XXXXXX h			
		Dimming Curve	Square Law Curve			(Default)
			S Law Curve			
			Linear Law Curve			
		Output / Fan Mode	Standard			(Default)
			Studio			
			Whisper			
		Dimming Speed	Fast			
			Slow			(Default)
		White Balance	Red			
			Green			
			Blue			
			Reset to default			
		Frequency	900Hz			
			910Hz			
			920Hz			
			930Hz			
			940Hz			
			950Hz			
			960Hz			
	980Hz					
	990Hz					
	1000Hz					
	1500Hz			(Default)		
	2500Hz					
	4000Hz					
	Tilt	Movement	Enable			(Default)
			Disable			
	Pan	Movement	Enable			(Default)
			Disable			
	Display	Orientation	Up			(Default)
			Down			
		On time	30 sec			(Default)
5 min						
10 min						
On						
Reset Defaults	Are you sure?					

TABLE 1. MENU FUNCTIONS							
LEVEL 1	LEVEL 2	LEVEL 3	LEVEL 4	LEVEL 5	LEVEL 6	DEFAULT	
DMX	Data	Ch 1 - Intensity XXX (Value)					
		Ch 2 - Intensity Fine XXX (Value)					
		...All functions					
	Pan /Tilt	Swap Pan / Tilt	Off				(Default)
			On				
		Invert Pan	Off				(Default)
			On				
		Invert Tilt	Off				(Default)
			On				
	DMX Mode	16-bit 1 Cell				(Default)	
		16-bit 7 Cell					
		8-bit 1 Cell					
8-bit 7 Cell							
No Data	Last output hold						
	Black out				(Default)		
Fixture	Status	(No Errors... or displays a list of errors)					
	Reboot Fixture	Are you sure?					
	Version	VXXX					
	Fixture Hours	XXXXXXX h					
	Crossload (software)	Send					
	Service	Service Settings	Optics Offset			Zoom	
		Diagnostics	Fan Check				
LED Temp							
Manual Control	Intensity	Value 0 - 255				(Default 0)	
	Intensity fine	Value 0 - 255				(Default 0)	
	...All functions	All functions			(Default 0)		
Test	All Test	(Run 'ALL TEST' )					
	Pan / Tilt Test	(Run 'PAN/TILT TEST' )					
	Test Channel	Intensity				(Run Intensity test)	
		Pan				(Run Pan test)	
		...All functions				...	
	Encoder Pan	XXXXXXXX - Displays Pan Encoder					
Encoder Tilt	XXXXXXXX - Displays Tilt Encoder						

**Address**

Address — DMX address setting. To select DMX Address, press the ENTER button to confirm. Use the UP/DOWN button to adjust the address from 001 to 512, press the ENTER button to store. Press the MENU button back to the last menu or let the unit idle one minute to exit menu mode.

**Configure**

To select Configure, press the ENTER button to confirm, use the UP/DOWN button to select LED, Tilt, Pan, Display or Reset Defaults.

**LED**

To select LED, press the ENTER button to confirm. Use the UP/DOWN button to select LED Hours, Dimming Curve, Dimming Speed, White Balance, Output / Fan Mode or Frequency, press the ENTER button to store. Press the MENU button back to the last menu or let the unit idle one minute to exit menu mode. Press the ENTER button to store. Press the MENU button back to the last menu or let the unit idle one minute to exit menu mode.

**LED Hours** — Select LED Hours, press the ENTER button to confirm, LED Hours will show on the display, press the MENU button back to exit.

**Dimming Curve** — To select Dimming Curve, press the ENTER button to confirm. Use the UP/DOWN button to select Square Law Curve, S Law Curve or Linear Law Curve, press the ENTER button to store. Press the MENU button back to the last menu or let the unit idle one minute to exit menu mode.

**Dimming Speed** — To select Dimming Speed, press the ENTER button to confirm. Use the UP/DOWN button to select Fast or Slow, press the ENTER button to store. Press the MENU button back to the last menu or let the unit idle one minute to exit menu mode.

**White Balance** — (White balance is an indicator of the white precision of the color mixing from red, green and blue.) To select White Balance, press the ENTER button to confirm. Use the UP/DOWN button to select Red, Green, Blue or Reset to default, press the ENTER button to store. Press the MENU button back to the last menu or let the unit idle one minute to exit menu mode.

**Output / Fan Mode** — To select Output / Fan Mode, press the ENTER button to confirm. Use the UP/DOWN button to select Standard, Studio, Whisper or Silent, press the ENTER button to store. Press the MENU button back to the last menu or let the unit idle one minute to exit menu mode.

**Frequency** — To select Frequency, press the ENTER button to confirm. Use the UP/DOWN button to select 900Hz, 910Hz, 920Hz, 930Hz, 940Hz, 950Hz, 960Hz, 970Hz, 980Hz, 990Hz, 1000Hz, 1500Hz, 2500Hz, 4000Hz press the ENTER button to store. Press the MENU button back to the last menu or let the unit idle one minute to exit menu mode.

**Tilt** — To select Tilt, press the ENTER button to confirm. Movement will show on the display, press the ENTER button to store. Use the UP/DOWN button to select Enable or Disable, press the ENTER button to store. Press the MENU button back to the last menu or let the unit idle one minute to exit menu mode.

**Pan** — To select Pan, press the ENTER button to confirm. Movement will show on the display, press the ENTER button to store. Use the UP/DOWN button to select Enable or Disable, press the ENTER button to store. Press the MENU button back to the last menu or let the unit idle one minute to exit menu mode.

**Display** — Select Display, press the ENTER button to confirm, Use the UP/DOWN button to select Orientation or On Time, press the ENTER button to store.

Select Orientation, press the ENTER button to confirm, Use the UP/DOWN button to select Up or Down, press the ENTER button to store. Press the MENU button back to the last menu or let the unit idle one minute to exit menu mode. Select On Time, press the ENTER button to confirm, Use the UP/DOWN button to select 30 Sec, 5 Min, 10 Min or On, press the ENTER button to store. Press the MENU button back to the last menu or let the unit idle one minute to exit menu mode.

**Reset Defaults** — Select Reset Defaults, press the ENTER button to confirm, Are you sure? will show on the display, press the ENTER button to store. Press the MENU button back to the last menu or let the unit idle one minute to exit menu mode.

## DMX

To select DMX, press the ENTER button to confirm, use the UP/DOWN button to select Data or DMX Mode.

**Data** — To select Data, press the ENTER button to confirm. Use the UP/DOWN button to select Ch 1 - Intensity, Ch 2 - Intensity Fine .... All functions, press the ENTER button to store. Press the MENU button back to the last menu or let the unit idle one minute to exit menu mode.

**Pan / Tilt** — To select Pan/Tilt, press the ENTER button to confirm. Use the UP/DOWN button to select Swap Pan/Tilt, Invert Pan or Invert Tilt, press the ENTER button to store. Use the UP/DOWN button to select Off or On, press the ENTER button to store. Press the MENU button back to the last menu or let the unit idle one minute to exit menu mode.

**DMX Mode** — To select DMX Mode, press the ENTER button to confirm. Use the UP/DOWN button to select 16-bit, 8-bit or Color Mode, press the ENTER button to store. Press the MENU button back to the last menu or let the unit idle one minute to exit menu mode.

**No Data** — To select No Data, press the ENTER button to confirm. Use the UP/DOWN button to select Last output hold or Black out, press the ENTER button to store. Press the MENU button back to the last menu or let the unit idle one minute to exit menu mode.

## Fixture

To select Fixture, press the ENTER button to confirm, use the UP/DOWN button to select Status, Reboot Fixture, Version, Fixture Hours, Crossload (Software) or Service.

### Status

Select Status, press the ENTER button to confirm, Status will show on the display, press the MENU button back to exit.

**Reboot Fixture**

Select Reboot Fixture, press the ENTER button to confirm, Are you sure? will show on the display, press the ENTER button to store. Press the MENU button back to the last menu or let the unit idle one minute to exit menu mode.

**Version**

Select Version, press the ENTER button to confirm, Version will show on the display, press the MENU button back to exit.

**Fixture Hours**

Select Fixture Hours, press the ENTER button to confirm, Fixture Hours will show on the display, press the MENU button back to exit.

**Crossload (Software)**

Select Crossload (Software), press the ENTER button to confirm, Send will show on the display, press the ENTER button to store. Press the MENU button back to the last menu or let the unit idle one minute to exit menu mode.

**Service**

To select Service, press the ENTER button to confirm. Use the UP/DOWN button to select Service Settings or Diagnostics, press the ENTER button to store. Press the MENU button back to the last menu or let the unit idle one minute to exit menu mode.

**Service Settings**

Select Service Settings, press the ENTER button to confirm. Optics Offset will show on the display, press the ENTER button to store, Zoom will show on the display. Press the MENU button back to the last menu or let the unit idle one minute to exit menu mode.

**Diagnostics**

To select Diagnostics, press the ENTER button to confirm. Use the UP/DOWN button to select Fan Check or Led Temp, press the ENTER button to store. Press the MENU button back to the last menu or let the unit idle one minute to exit menu mode.

**Manual Control**

Enter menu mode, select Manual Control, press the ENTER button to confirm, use the UP/DOWN button to select Intensity, Intensity fine...All functions. Use the UP/DOWN button to adjust the value from 0 to 255, press the ENTER button to store. Press the MENU button back to the last menu or let the unit idle one minute to exit menu mode.

**Test**

Enter menu mode, select Test, press the ENTER button to confirm, use the UP/DOWN button to select All Test, Pan/Tilt Test, Test Channel, Encoder Pan or Encoder Tilt.

**All Test**

Select All Test, press the ENTER button to confirm, the unit will run all test. Press the MENU button back to the last menu or exit menu mode after auto test.

**Pan/Tilt Test**

Select Pan/Tilt Test, press the ENTER button to confirm, the unit will run Pan/Tilt test. Press the MENU button back to the last menu or exit menu mode after auto test.

**Test Channel**

To select Test Channel, press the ENTER button to confirm, the present channel will show on the display, use the UP/DOWN button to select channel Intensity ...All functions, press the ENTER button to confirm, then use the UP/DOWN button to adjust the value, press the ENTER button to store, the fixture will run as the channel value indicates. Press the MENU button back to the last menu or exit menu mode idling one minute.

**Encoder Pan**

Select Encoder Pan, press the ENTER button to confirm, displays pan encoder will show on the display. Press the MENU button back to the last menu or exit menu mode after auto test.

**Encoder Tilt**

Select Encoder Tilt, press the ENTER button to confirm, displays tilt encoder will show on the display. Press the MENU button back to the last menu or exit menu mode after auto test.

# HOW TO CONTROL THE FIXTURE

---

The fixture can be operated by DMX controller.

## DMX512 CONFIGURATION

**TABLE 2. 16-BIT 1 CELL DMX MAP**

CHANNEL	FUNCTION	DEFAULT	RANGE	DESCRIPTION
1	Intensity High	0	0-65535	16-bit control of dimming
2	Intensity Low			
3	Pan High	32767	0-65535	16-bit movement control PAN, 540° end to end travel
4	Pan Low			
5	Tilt High	32767	0-65535	16-bit Movement control Tilt, 220° end to end travel
6	Tilt Low			
7	Zoom	128	0 - 255	Zoom control, Narrow 0 >>>> 255 Wide
8	Red High	0	0-65535	16-bit control of color
9	Red Low			
10	Green High	0	0-65535	16-bit control of color
11	Green Low			
12	Blue High	0	0-65535	16-bit control of color
13	Blue Low			
14	White High	0	0-65535	16-bit control of color
15	White Low			



**TABLE 2. 16-BIT 1 CELL DMX MAP**

CHANNEL	FUNCTION	DEFAULT	RANGE	DESCRIPTION
			0 - 255	
			0 - 68	Channel OFF (RGBW enabled)
			69 - 70	CF_0_Color OFF
			71 - 72	CF_1_White 10000K
			73 - 74	CF_2_White 8000K
			75 - 76	CF_3_White 6500K
			77 - 78	CF_4_White 5600K
			79 - 80	CF_5_White 5000K
			81 - 82	CF_6_White 4500K
			83 - 84	CF_7_White 4000K
			85 - 86	CF_8_White 3200K
			87 - 88	CF_9_White 3000K
			89 - 90	CF_10_White 2700K
			91 - 92	CF_11_Moroccan Pink
			93 - 94	CF_12_Pink
			95 - 96	CF_13_Flesh Pink
			97 - 98	CF_14_Bright Rose
			99 - 100	CF_15_Follies Pink
			101 - 102	CF_16_Fuchsia Pink
			103 - 104	CF_17_Surprise Pink
			105 - 106	CF_18_Congo Blue
			107 - 108	CF_19_Blue
			109 - 110	CF_20_Virgin Blue
			111 - 112	CF_21_Midnight Maya
			113 - 114	CF_22_Diuble C.T Blue
			115 - 116	CF_23_Slate Blue
			117 - 118	CF_24_Regal Blue
			119 - 120	CF_25_Fullt C.T Blue
			121 - 122	CF_26_Steel Blue
			123 - 124	CF_27_Lighter Blue
			125 - 126	CF_28_Cyan
			127 - 128	CF_29_Marine Blue
			129 - 130	CF_30_Soft Green
			131 - 132	CF_31_Moss Green
			133 - 134	CF_32_Green
			135 - 136	CF_33_Fem Green
			137 - 138	CF_34_JAS Green
			139 - 140	CF_35_Pale Green
			141 - 142	CF_36_Spring Yellow
			143 - 144	CF_37_Yellow
			145 - 146	CF_38_Deep Amber
			147 - 148	CF_39_Chrome Orange
			149 - 150	CF_40_Orange
			151 - 152	CF_41_Magenta
			153 - 154	CF_42_Flame Red
			155 - 156	CF_43_Purple
			157 - 187	Rotate CW Fast Slow
			188 - 208	Rotate CCW Fast Slow
			209 - 229	Random Color Fast Slow
			229 - 255	Channel off
16	Color Preset	0		
17	Strobe Speed	0	0 - 255	Controls strobe rate from slowest (DMX 0) to fastest (DMX 255) 0.5Hz to 30Hz
18	Strobe Control	0 - 255	0 - 255 0 - 5 6 - 10 11 - 15 16 - 20 21 - 25 26 - 255	Control Channel for strobing functions. Open* Open Closed Normal Strobe Random Strobe Random Sync Reserved Values
19	Focus Timing	255	0 - 255	Adjustment of fixture timing to control Pan/Tilt mechanisms.
20	Optics Timing	255	0 - 255	Adjustment of fixture timing to control lensing mechanisms.
21	Color Timing	255	0 - 255	Adjustment of fixture timing to control color mechanisms.

**TABLE 2. 16-BIT 1 CELL DMX MAP**

CHANNEL	FUNCTION	DEFAULT	RANGE	DESCRIPTION
22	Control Channel	0	0 - 255	Control Channel used for full fixture settings, lamp controls, and miscellaneous modes. Set discrete value of desired effect, wait >3 seconds, then set value to 0 (Idle).
			0 - 5	Idle (Default)
			6 - 10	Full Luminaire ReCal - Also Used to Wake fixture up from shutdown
			11 - 15	Reserved Values
			16 - 20	Reserved Values
			21 - 25	Fixture Shutdown
			26 - 30	Display - Menu ON
			31 - 35	Display - Menu OFF
			36 - 40	Dimming Curve Linear
			41 - 45	Dimming Curve S-Curve
			46 - 50	Dimming Curve Square Curve (Default)**
			51 - 55	Reserved Values
			56 - 60	Reserved Values
			61 - 65	Dimmer Snap On (Fast snaps)
			66 - 70	Dimmer Snap Off (Default) (Smooth Dimming)
			71 - 75	Color Calibration on
			76 - 80	Color Calibration off (Default)
81 - 85	Standard Mode - Fixture operates at maximum output (Default)			
86 - 90	Studio Mode - Reduced output with lower fan settings			
91 - 100	Whisper Mode - Reduced output with lower fan settings			
101 - 110	Reserved Values			
111 - 120	Fan On (Default)			
121 - 130	Fan Auto			
131 - 255	Reserved Values			

**TABLE 3. 16-BIT 7 CELL**

CHANNEL	FUNCTION	DEFAULT	RANGE	DESCRIPTION
1	Intensity High	0	0-65535	16-bit control of Dimming
2	Intensity Low			
3	Pan High	32767	0-65535	16-bit Movement control PAN, 540° end to end travel
4	Pan Low			
5	Tilt High	32767	0-65535	16-bit Movement control Tilt, 220° end to end travel
6	Tilt Low			
7	Zoom	128	0 - 255	Zoom control, Narrow 0 >>>> 255 Wide
8	Red High 1	0	0-65535	16-bit control of color
9	Red Low 1			
10	Green High 1	0	0-65535	16-bit control of color
11	Green Low 1			
12	Blue High 1	0	0-65535	16-bit control of color
13	Blue Low 1			
14	White High 1	0	0-65535	16-bit control of color
15	White Low 1			
16	Red High 2	0	0-65535	16-bit control of color
17	Red Low 2			
18	Green High 2	0	0-65535	16-bit control of color
19	Green Low 2			
20	Blue High 2	0	0-65535	16-bit control of color
21	Blue Low 2			
22	White High 2	0	0-65535	16-bit control of color
23	White Low 2			

<b>TABLE 3. 16-BIT 7 CELL</b>				
<b>CHANNEL</b>	<b>FUNCTION</b>	<b>DEFAULT</b>	<b>RANGE</b>	<b>DESCRIPTION</b>
24	Red High 3	0	0-65535	16-bit control of color
25	Red Low 3			
26	Green High 3	0	0-65535	16-bit control of color
27	Green Low 3			
28	Blue High 3	0	0-65535	16-bit control of color
29	Blue Low 3			
30	White High 3	0	0-65535	16-bit control of color
31	White Low 3			
32	Red High 4	0	0-65535	16-bit control of color
33	Red Low 4			
34	Green High 4	0	0-65535	16-bit control of color
35	Green Low 4			
36	Blue High 4	0	0-65535	16-bit control of color
37	Blue Low 4			
38	White High 4	0	0-65535	16-bit control of color
39	White Low 4			
40	Red High 5	0	0-65535	16-bit control of color
41	Red Low 5			
42	Green High 5	0	0-65535	16-bit control of color
43	Green Low 5			
44	Blue High 5	0	0-65535	16-bit control of color
45	Blue Low 5			
46	White High 5	0	0-65535	16-bit control of color
47	White Low 5			
48	Red High 6	0	0-65535	16-bit control of color
49	Red Low 6			
50	Green High 6	0	0-65535	16-bit control of color
51	Green Low 6			
52	Blue High 6	0	0-65535	16-bit control of color
53	Blue Low 6			
54	White High 6	0	0-65535	16-bit control of color
55	White Low 6			
56	Red High 7	0	0-65535	16-bit control of color
57	Red Low 7			
58	Green High 7	0	0-65535	16-bit control of color
59	Green Low 7			
60	Blue High 7	0	0-65535	16-bit control of color
61	Blue Low 7			
62	White High 7	0	0-65535	16-bit control of color
63	White Low 7			

<b>TABLE 3. 16-BIT 7 CELL</b>				
<b>CHANNEL</b>	<b>FUNCTION</b>	<b>DEFAULT</b>	<b>RANGE</b>	<b>DESCRIPTION</b>
64	Color Preset	0	0 - 255 0 - 68 69 - 70 71 - 72 73 - 74 75 - 76 77 - 78 79 - 80 81 - 82 83 - 84 85 - 86 87 - 88 89 - 90 91 - 92 93 - 94 95 - 96 97 - 98 99 - 100 101 - 102 103 - 104 105 - 106 107 - 108 109 - 110 111 - 112 113 - 114 115 - 116 117 - 118 119 - 120 123 - 124 123 - 124 125 - 126 127 - 128 129 - 130 131 - 132 133 - 134 135 - 136 137 - 138 139 - 140 141 - 142 143 - 144 145 - 146 147 - 148 149 - 150 151 - 152 153 - 154 155 - 156 157 - 187 188 - 208 209 - 229 229 - 255	Channel OFF (RGBW enabled) CF_0_Color OFF CF_1_White 10000K CF_2_White 8000K CF_3_White 6500K CF_4_White 5600K CF_5_White 5000K CF_6_White 4500K CF_7_White 4000K CF_8_White 3200K CF_9_White 3000K CF_10_White 2700K CF_11_Moroccan Pink CF_12_Pink CF_13_Flesh Pink CF_14_Bright Rose CF_15_Follies Pink CF_16_Fuchsia Pink CF_17_Surprise Pink CF_18_Congo Blue CF_19_Blue CF_20_Virgin Blue CF_21_Midnight Maya CF_22_Duble C.T Blue CF_23_Slate Blue CF_24_Regal Blue CF_25_Fullt C.T Blue CF_26_Steel Blue CF_27_Lighter Blue CF_28_Cyan CF_29_Marine Blue CF_30_Soft Green CF_31_Moss Green CF_32_Green CF_33_Fem Green CF_34_JAS Green CF_35_Pale Green CF_36_Spring Yellow CF_37_Yellow CF_38_Deep Amber CF_39_Chrome Orange CF_40_Orange CF_41_Magenta CF_42_Flame Red CF_43_Purple Rotate CW Fast Slow Rotate CCW Fast Slow Random Color Fast Slow Channel off
65	Strobe Speed	0	0 - 255	Controls strobe rate from slowest (DMX 0) to fastest (DMX 255), 0.5hz to 30hz
66	Strobe Control	0 - 255	0 - 255 0 - 5 6 - 10 11 - 15 16 - 20 21 - 25 26 - 255	Control Channel for strobing functions. Open* Open Closed Normal Strobe Random Strobe Random Sync Reserved Values
67	Focus Timing	255	0 - 255	Adjustment of fixture timing to control Pan/Tilt mechanisms.
68	Optics Timing	255	0 - 255	Adjustment of fixture timing to control lensing mechanisms.
69	Color Timing	255	0 - 255	Adjustment of fixture timing to control color mechanisms.

CHANNEL	FUNCTION	DEFAULT	RANGE	DESCRIPTION
70	Control Channel	0	0 - 255	Control Channel used for full fixture settings, lamp controls, and miscellaneous modes. Set discrete value of desired effect, wait >3 seconds, then set value to 0 (Idle).  Idle (Default) 0 - 5 Full Luminaire ReCal - Also Used to Wake fixture up from shutdown 6 - 10 Reserved Values 11 - 15 Reserved Values 16 - 20 Reserved Values 21 - 25 Fixture Shutdown 26 - 30 Display - Menu ON 31 - 35 Display - Menu OFF 36 - 40 Dimming Curve Linear 41 - 45 Dimming Curve S-Curve 46 - 50 Dimming Curve Square Curve (Default)** 51 - 55 Reserved Values 56 - 60 Reserved Values 61 - 65 Dimmer Snap On (Fast snaps) 66 - 70 Dimmer Snap Off (Default) (Smooth Dimming) 71 - 75 Color Calibration on 76 - 80 Color Calibration off (Default) 81 - 85 Standard Mode - Fixture operates at maximum output (Default) 86 - 90 Studio Mode - Reduced output with lower fan settings 91 - 100 Whisper Mode - Redcued output with lower fan settings 101 - 110 Reserved Values 111 - 120 Fan On (Default) 121 - 130 Fan Auto 131 - 255 Reserved Values

CHANNEL	FUNCTION	DEFAULT	RANGE	DESCRIPTION
1	Intensity High	0	0 - 255	8 Bit control of Dimming
2	Pan High	32767	0-65535	16-bit Movement control PAN, 720° end to end travel
3	Pan Low			
4	Tilt High	32767	0-65535	16-bit Movement control Tilt 220° end to end travel
5	Tilt Low			
6	Zoom	128	0 - 255	Zoom control, Narrow 0 >>>> 255 Wide
7	Red High	0	0 - 255	8 Bit control of color
8	Green High	0	0 - 255	8 Bit control of color
9	Blue High	0	0 - 255	8 Bit control of color
10	White High	0	0 - 255	8 Bit control of color

<b>TABLE 4. 8-BIT 1 CELL</b>				
<b>CHANNEL</b>	<b>FUNCTION</b>	<b>DEFAULT</b>	<b>RANGE</b>	<b>DESCRIPTION</b>
11	Color Preset	0	0 - 255	
			0 - 68	Channel OFF (RGBW enabled)
			69 - 70	CF_0_Color OFF
			71 - 72	CF_1_White 10000K
			73 - 74	CF_2_White 8000K
			75 - 76	CF_3_White 6500K
			77 - 78	CF_4_White 5600K
			79 - 80	CF_5_White 5000K
			81 - 82	CF_6_White 4500K
			83 - 84	CF_7_White 4000K
			85 - 86	CF_8_White 3200K
			87 - 88	CF_9_White 3000K
			89 - 90	CF_10_White 2700K
			91 - 92	CF_11_Moroccan Pink
			93 - 94	CF_12_Pink
			95 - 96	CF_13_Flesh Pink
			97 - 98	CF_14_Bright Rose
			99 - 100	CF_15_Follies Pink
			101 - 102	CF_16_Fuchsia Pink
			103 - 104	CF_17_Surprise Pink
105 - 106	CF_18_Congo Blue			
107 - 108	CF_19_Blue			
109 - 110	CF_20_Virgin Blue			
111 - 112	CF_21_Midnight Maya			
113 - 114	CF_22_Dluble C.T Blue			
115 - 116	CF_23_Slate Blue			
117 - 118	CF_24_Regal Blue			
119 - 120	CF_25_Fullt C.T Blue			
121 - 122	CF_26_Steel Blue			
123 - 124	CF_27_Lighter Blue			
125 - 126	CF_28_Cyan			
127 - 128	CF_29_Marine Blue			
129 - 130	CF_30_Soft Green			
131 - 132	CF_31_Moss Green			
133 - 134	CF_32_Green			
135 - 136	CF_33_Fem Green			
137 - 138	CF_34_JAS Green			
139 - 140	CF_35_Pale Green			
141 - 142	CF_36_Spring Yellow			
143 - 144	CF_37_Yellow			
145 - 146	CF_38_Deep Amber			
147 - 148	CF_39_Chrome Orange			
149 - 150	CF_40_Orange			
151 - 152	CF_41_Magenta			
153 - 154	CF_42_Flame Red			
155 - 156	CF_43_Purple			
157 - 187	Rotate CW Fast Slow			
188 - 208	Rotate CCW Fast Slow			
209 - 229	Random Color Fast Slow			
229 - 255	Channel off			
12	Strobe Speed	0	0 - 255	Controls strobe rate from slowest (DMX 0) to fastest (DMX 255), 0.5hz to 30hz
13	Strobe Control	0 - 255	0 - 255 0 - 5 6 - 10 11 - 15 16 - 20 21 - 25 26 - 255	Control Channel for strobing functions. Open* Open Closed Normal Strobe Random Strobe Random Sync Reserved Values
14	Focus Timing	255	0 - 255	Adjustment of fixture timing to control Pan/Tilt mechanisms.
15	Optics Timing	255	0 - 255	Adjustment of fixture timing to control lensing mechanisms.
16	Color Timing	255	0 - 255	Adjustment of fixture timing to control color mechanisms.

CHANNEL	FUNCTION	DEFAULT	RANGE	DESCRIPTION
17	Control Channel	0	0 - 255	Control Channel used for full fixture settings, lamp controls, and miscellaneous modes. Set discrete value of desired effect, wait >3 seconds, then set value to 0 (Idle).
			0 - 5	Idle (Default)
			6 - 10	Full Luminaire ReCal - Also Used to Wake fixture up from shutdown
			11 - 15	Reserved Values
			16 - 20	Reserved Values
			21 - 25	Reserved Values
			26 - 30	Fixture Shutdown
			31 - 35	Display - Menu ON
			36 - 40	Display - Menu OFF
			41 - 45	Dimming Curve Linear
			46 - 50	Dimming Curve S-Curve
			51 - 55	Dimming Curve Square Curve (Default)**
			56 - 60	Reserved Values
			61 - 65	Reserved Values
			66 - 70	Dimmer Snap On (Fast snaps)
			71 - 75	Dimmer Snap Off (Default) (Smooth Dimming)
			76 - 80	Color Calibration on
			81 - 85	Color Calibration off (Default)
			86 - 90	Standard Mode - Fixture operates at maximum output (Default)
			91 - 100	Studio Mode - Reduced output with lower fan settings
			101 - 110	Whisper Mode - Redcued output with lower fan settings
			111 - 120	Reserved Values
			121 - 130	Fan On (Default)
			131 - 255	Fan Auto Reserved Values

CHANNEL	FUNCTION	DEFAULT	RANGE	DESCRIPTION
1	Intensity High	0	0 - 255	8 Bit control of Dimming
2	Pan High	32767	0-65535	16 Bit Movement control PAN, 720° end to end travel
3	Pan Low			
4	Tilt High	32767	0-65535	16 Bit Movement control Tilt, 220° end to end travel
5	Tilt Low			
6	Zoom	128	0 - 255	Zoom control, Narrow 0 >>>> 255 Wide
7	Red High 1	0	0 - 255	8 Bit control of color
8	Green High 1	0	0 - 255	8 Bit control of color
9	Blue High 1	0	0 - 255	8 Bit control of color
10	White High 1	0	0 - 255	8 Bit control of color
11	Red High 2	0	0 - 255	8 Bit control of color
12	Green High 2	0	0 - 255	8 Bit control of color
13	Blue High 2	0	0 - 255	8 Bit control of color
14	White High 2	0	0 - 255	8 Bit control of color
15	Red High 3	0	0 - 255	8 Bit control of color
16	Green High 3	0	0 - 255	8 Bit control of color
17	Blue High 3	0	0 - 255	8 Bit control of color
18	White High 3	0	0 - 255	8 Bit control of color
19	Red High 4	0	0 - 255	8 Bit control of color
20	Green High 4	0	0 - 255	8 Bit control of color
21	Blue High 4	0	0 - 255	8 Bit control of color
22	White High 4	0	0 - 255	8 Bit control of color
23	Red High 5	0	0 - 255	8 Bit control of color
24	Green High 5	0	0 - 255	8 Bit control of color
25	Blue High 5	0	0 - 255	8 Bit control of color

<b>TABLE 5. 8-BIT 1 CELL</b>				
<b>CHANNEL</b>	<b>FUNCTION</b>	<b>DEFAULT</b>	<b>RANGE</b>	<b>DESCRIPTION</b>
26	White High 5	0	0 - 255	8 Bit control of color
27	Red High 6	0	0 - 255	8 Bit control of color
28	Green High 6	0	0 - 255	8 Bit control of color
29	Blue High 6	0	0 - 255	8 Bit control of color
30	White High 6	0	0 - 255	8 Bit control of color
31	Red High 7	0	0 - 255	8 Bit control of color
32	Green High 7	0	0 - 255	8 Bit control of color
33	Blue High 7	0	0 - 255	8 Bit control of color
34	White High 7	0	0 - 255	8 Bit control of color
35	Color Preset	0	0 - 255 0 - 68 69 - 70 71 - 72 73 - 74 75 - 76 77 - 78 79 - 80 81 - 82 83 - 84 85 - 86 87 - 88 89 - 90 91 - 92 93 - 94 95 - 96 97 - 98 99 - 100 101 - 102 103 - 104 105 - 106 107 - 108 109 - 110 111 - 112 113 - 114 115 - 116 117 - 118 119 - 120 121 - 122 123 - 124 125 - 126 127 - 128 129 - 130 131 - 132 133 - 134 135 - 136 137 - 138 139 - 140 141 - 142 143 - 144 145 - 146 147 - 148 149 - 150 151 - 152 153 - 154 155 - 156 157 - 187 188 - 208 209 - 229 229 - 255	Channel OFF (RGBW enabled) CF_0_Color OFF CF_1_White 10000K CF_2_White 8000K CF_3_White 6500K CF_4_White 5600K CF_5_White 5000K CF_6_White 4500K CF_7_White 4000K CF_8_White 3200K CF_9_White 3000K CF_10_White 2700K CF_11_Moroccan Pink CF_12_Pink CF_13_Flesh Pink CF_14_Bright Rose CF_15_Follies Pink CF_16_Fuchsia Pink CF_17_Surprise Pink CF_18_Congo Blue CF_19_Blue CF_20_Virgin Blue CF_21_Midnight Maya CF_22_Dluble C.T Blue CF_23_Slate Blue CF_24_Regal Blue CF_25_Fullt C.T Blue CF_26_Steel Blue CF_27_Lighter Blue CF_28_Cyan CF_29_Marine Blue CF_30_Soft Green CF_31_Moss Green CF_32_Green CF_33_Fem Green CF_34_JAS Green CF_35_Pale Green CF_36_Spring Yellow CF_37_Yellow CF_38_Deep Amber CF_39_Chrome Orange CF_40_Orange CF_41_Magenta CF_42_Flame Red CF_43_Purple Rotate CW Fast Slow Rotate CCW Fast Slow Random Color Fast Slow Channel off
36	Strobe Speed	0	0 - 255	Controls strobe rate from slowest (DMX 0) to fastest (DMX 255), 0.5hz to 30hz



CHANNEL	FUNCTION	DEFAULT	RANGE	DESCRIPTION
37	Strobe Control	0 - 255	0 - 255 0 - 5 6 - 10 11 - 15 16 - 20 21 - 25 26 - 255	Control Channel for strobing functions. Open* Open Closed Normal Strobe Random Strobe Random Sync Reserved Values
38	Focus Timing	255	0 - 255	Adjustment of fixture timing to control Pan/Tilt mechanisms.
39	Optics Timing	255	0 - 255	Adjustment of fixture timing to control lensing mechanisms.
40	Color Timing	255	0 - 255	Adjustment of fixture timing to control color mechanisms.
41	Control Channel	0	0 - 255  0 - 5 6 - 10 11 - 15 16 - 20 21 - 25 26 - 30 31 - 35 36 - 40 41 - 45 46 - 50 51 - 55 56 - 60 61 - 65 66 - 70 71 - 75 76 - 80 81 - 85 86 - 90 91 - 100 101 - 110 111 - 120 121 - 130 131 - 255	Control Channel used for full fixture settings, lamp controls, and miscellaneous modes. Set discrete value of desired effect, wait >3 seconds, then set value to 0 (Idle).  Idle (Default) Full Luminaire ReCal - Also Used to Wake fixture up from shutdown Reserved Values Reserved Values Fixture Shutdown Display - Menu ON Display - Menu OFF Dimming Curve Linear Dimming Curve S-Curve Dimming Curve Square Curve (Default)** Reserved Values Reserved Values Dimmer Snap On (Fast snaps) Dimmer Snap Off (Default) (Smooth Dimming) Color Calibration on Color Calibration off (Default) Standard Mode - Fixture operates at maximum output (Default) Studio Mode - Reduced output with lower fan settings Whisper Mode - Redcued output with lower fan settings Silent mode - Redcued output Fans deactivates Fan On (Default) Fan Auto Reserved Values

CHANNEL	16-BIT 1 CELL	16-BIT 7 CELL	8-BIT 1 CELL	8-BIT 7 CELL
1	Intensity High	Intensity High	Intensity	Intensity
2	Intensity Low	Intensity Low	Pan High	Pan High
3	Pan High	Pan High	Pan Low	Pan Low
4	Pan Low	Pan Low	Tilt High	Tilt High
5	Tilt High	Tilt High	Tilt Low	Tilt Low
6	Tilt Low	Tilt Low	Zoom	Zoom
7	Zoom	Zoom	Red	Red
8	Red High	Red High-1	Green	Green
9	Red Low	Red Low-1	Blue	Blue
10	Green High	Green High-1	White	White
11	Green Low	Green Low-1	Color Preset	Red
12	Blue High	Blue High-1	Strobe Speed	Green
13	Blue Low	Blue Low-1	Strobe Control	Blue
14	White High	White High-1	Focus Timing	White
15	White Low	White Low-1	Optics Timing	Red

<b>TABLE 6. DMX MAP - ALL</b>				
<b>CHANNEL</b>	<b>16-BIT 1 CELL</b>	<b>16-BIT 7 CELL</b>	<b>8-BIT 1 CELL</b>	<b>8-BIT 7 CELL</b>
16	Color Preset	Red High-2	Color Timing	Green
17	Strobe Speed	Red Low-2	Control Channel	Blue
18	Strobe Control	Green High-2		White
19	Focus Timing	Green Low-2		Red
20	Optics Timing	Blue High-2		Green
21	Color Timing	Blue Low-2		Blue
22	Control Channel	White High-2		White
23		White Low-2		Red
24		Red High-3		Green
25		Red Low-3		Blue
26		Green High-3		White
27		Green Low-3		Red
28		Blue High-3		Green
29		Blue Low-3		Blue
30		White High-3		White
31		White Low-3		Red
32		Red High-4		Green
33		Red Low-4		Blue
34		Green High-4		White
35		Green Low-4		Color Preset
36		Blue High-4		Strobe Speed
37		Blue Low-4		Strobe Control
38		White High-4		Focus Timing
39		White Low-4		Optics Timing
40		Red High-5		Color Timing
41		Red Low-5		Control Channel
42		Green High-5		
43		Green Low-5		
44		Blue High-5		
45		Blue Low-5		
46		White High-5		
47		White Low-5		
48		Red High-6		
49		Red Low-6		
50		Green High-6		
51		Green Low-6		
52		Blue High-6		
53		Blue Low-6		
54		White High-6		
55		White Low-6		
56		Red High-7		
57		Red Low-7		
58		Green High-7		
59		Green Low-7		
60		Blue High-7		
61		Blue Low-7		
62		White High-7		
63		White Low-7		
64		Color Preset		

CHANNEL	16-BIT 1 CELL	16-BIT 7 CELL	8-BIT 1 CELL	8-BIT 7 CELL
65		Strobe Speed		
66		Strobe Control		
67		Focus Timing		
68		Optics Timing		
69		Color Timing		
70		Control Channel		

## DMX512 CONNECTION

- At last unit, the DMX cable has to be terminated with a terminator. Solder a 120Ω 1/4W resistor between pin 2(DMX-) and pin 3(DMX+) into a 5-pin XLR-plug and plug it in the DMX-output of the last unit.
- Connect the unit together in a `daisy chain` by XLR plug from the output of the unit to the input of the next unit. The cable can not be branched or split to a `Y` cable. DMX 512 is a very high-speed signal. Inadequate or damaged cables, soldered joints or corroded connectors can easily distort the signal and shut down the system.
- The DMX output and input connectors are pass-through to maintain the DMX circuit, when one of the units' power is disconnected.
- Each lighting unit needs to have an address set to receive the data sent by the controller. The address number is between 0-511 (usually 0 & 1 are equal to 1).
- The end of the DMX 512 system should be terminated to reduce signal errors.

## MAINTENANCE

### TROUBLESHOOTING

Following are a few common problems that may occur during operation.

**The unit does not work - light and fan do not turn on.**

- Check the connection of power and main fuse.
- Measure the mains voltage on the main connector.

**Not responding to DMX controller**

- DMX LED should be on. If not, check DMX connectors, cables to see if link properly.
- If the DMX LED is on and no response to the channel, check the address settings and DMX polarity.
- If you have intermittent DMX signal problems, check the pins on connectors or on PCB of the unit or the previous one.
- Try to use another DMX controller.
- Check if the DMX cables run near or run alongside to high voltage cables that may cause damage or interference to DMX interface circuit.

### CLEANING

The cleaning of internal must be carried out periodically to optimize light output. Cleaning frequency depends on the environment in which the fixture operates: damp, smoky or particularly dirty surrounding can cause greater accumulation of dirt on the fixture's optics.

- Clean with soft cloth using normal glass cleaning fluid.
- Always dry the parts carefully.
- Clean the external optics at least every 30 days.

## TECHNICAL SPECIFICATIONS

Refer to the product data sheet available for download on [www.vari-lite.com](http://www.vari-lite.com).

**TABLE 7. 8-BIT CHANNEL MODE**

CHANNEL	FUNCTION	VALUE	DESCRIPTION
1	Intensity	0-65535	16-bit control of dimming
2	Zoom	0-65535	Zoom control ,0-100% (Narrow -> Wide)
3	Red	0-65535	16-bit control of color
4	Green	0-65535	16-bit control of color
5	Blue	0-65535	16-bit control of color
6	White	0-65535	16-bit control of color
7	Color preset	000-068	Channel OFF
		069-070	CF_0_Color OFF
		071-072	CF_1_White 10000K
		073-074	CF_2_White 8000K
		075-076	CF_3_White 6500K
		077-078	CF_4_White 5600K
		079-080	CF_5_White 5000K
		081-082	CF_6_White 4500K
		083-084	CF_7_White 4000K
		085-086	CF_8_White 3200
		087-088	CF_9_White 3000K
		089-090	CF_10_White 2700K
		091-092	CF_11_Moroccan Pink
		093-094	CF_12_Pink
		095-096	CF_13_Flesh Pink
		097-098	CF_14_Bright Rose
		099-100	CF_15_Follies Pink
		101-102	CF_16_Fuchsia Pink
		103-104	CF_17_Surprise Pink
		105-106	CF_18_Congo Blue
		107-108	CF_19_Blue
		109-110	CF_20_Virgin Blue
		111-112	CF_21_Midnight Maya
		113-114	CF_22_Dluble C.T Blue
		115-116	CF_23_Slate Blue
		117-118	CF_24_Regal Blue
		119-120	CF_25_Fullt C.T Blue
		121-122	CF_26_Steel Blue
		123-124	CF_27_Lighter Blue
		125-126	CF_28_Cyan
		127-128	CF_29_Marine Blue
		129-130	CF_30_Soft Green
131-132	CF_31_Moss Green		
133-134	CF_32_Green		
135-136	CF_33_Fem Green		
137-138	CF_34_JAS Green		
139-140	CF_35_Pale Green		
141-142	CF_36_Spring Yellow		
143-144	CF_37_Yellow		
145-146	CF_38_Deep Amber		
147-148	CF_39_Chrome Orange		
149-150	CF_40_Orange		
151-152	CF_41_Magenta		
153-154	CF_42_Flame Red		
155-156	CF_43_Purple		
157-187	Rotate CW Fast Slow		
188-208	Rotate CCW Fast Slow		
209-229	Random Color Fast Slow		
230-255	Channel off		
8	Strobe speed	000-255	0.5Hz to 30Hz
9	Strobe speed	000-005	Open
		006-010	Closed
		011-015	Normal Strobe
		016-020	Random Strobe
		021-025	Random Sync
		026-255	Reserved Values

**TABLE 7. 8-BIT CHANNEL MODE**

CHANNEL	FUNCTION	VALUE	DESCRIPTION
10	Control channel	000-005	Idle(Default)
		006-010	Full Luminaire ReCal
		011-015	Reserved Values
		016-020	Reserved Values
		021-025	Fixture Shutdow
		026-030	Display - Menu ON
		031-035	Display - Menu OFF
		036-040	Dimming Curve Linear
		041-045	Dimming Curve S-Curve
		046-050	Dimming Curve Square Curve (Default)**
		051-055	Reserved Values
		056-060	Reserved Values
		061-065	Dimmer Snap On
		066-070	Dimmer Snap Off (Default)
		071-075	Reserved Values
		076-080	Reserved Values
		081-085	Standard Mode
		086-090	Studio Mode
		091-100	Fan On (Default)
101-110	Fan Auto		
111-255	Reserved Values		

**TABLE 8. 8-BIT COLOR MODE**

CHANNEL	FUNCTION	VALUE	DESCRIPTION
1	Zoom	000-255	16-bit control of dimming
2	Red	0-65535	Zoom control, 0-100% (narrow -> wide)
3	Green	0-65535	16-bit control of color
4	Blue	0-65535	16-bit control of color
5	White	0-65535	16-bit control of color

## DMX512 CONNECTION

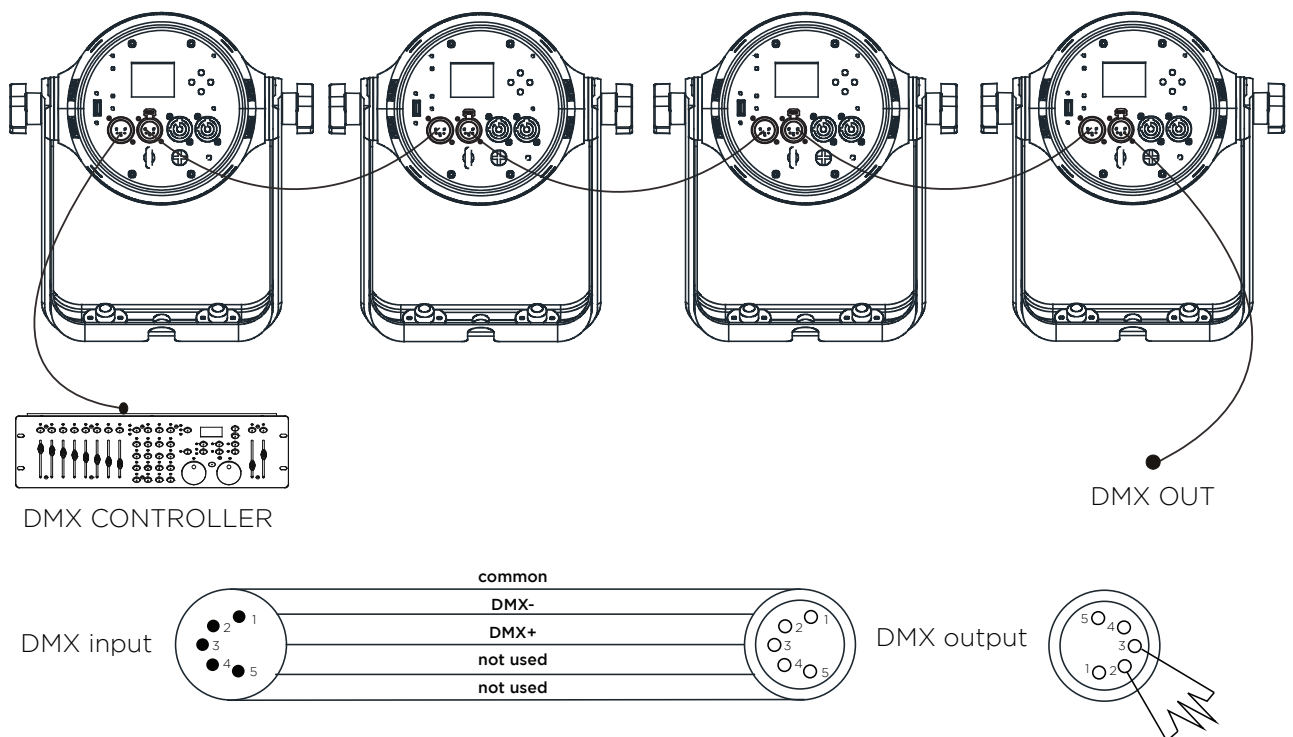

- At last unit, the DMX cable has to be terminated with a terminator. Solder a 120Ω 1/4W resistor between pin 2(DMX-) and pin 3(DMX+) into a 5-pin XLR-plug and plug it in the DMX-output of the last unit.
- Connect the unit together in a `daisy chain` by XLR plug from the output of the unit to the input of the next unit. The cable can not be branched or split to a `Y` cable. DMX 512 is a very high-speed signal. Inadequate or damaged cables, soldered joints or corroded connectors can easily distort the signal and shut down the system.
- The DMX output and input connectors are pass-through to maintain the DMX circuit, when one of the units' power is disconnected.
- Each lighting unit needs to have an address set to receive the data sent by the controller. The address number is between 0-511 (usually 0 & 1 are equal to 1).
- The end of the DMX 512 system should be terminated to reduce signal errors.
- 5 pin XLR: Pin 1: GND, Pin 2: Negative signal (-), Pin 3: Positive signal (+), Pin 4/Pin 5: Not used.

## MAINTENANCE

---

### TROUBLESHOOTING

Following are a few common problems that may occur during operation.

**The unit does not work - light and fan do not turn on.**

- Check the connection of power and main fuse.
- Measure the mains voltage on the main connector.

**Not responding to DMX controller**

- DMX LED should be on. If not, check DMX connectors, cables to see if link properly.
- If the DMX LED is on and no response to the channel, check the address settings and DMX polarity.
- If you have intermittent DMX signal problems, check the pins on connectors or on PCB of the unit or the previous one.
- Try to use another DMX controller.
- Check if the DMX cables run near or run alongside to high voltage cables that may cause damage or interference to DMX interface circuit.

### CLEANING

Cleaning must be carried out periodically to optimize light output. Cleaning frequency depends on the environment in which the fixture operates: damp, smoky or particularly dirty environments cause greater accumulation of dirt on the fixture's optics.

- Clean with soft cloth using normal glass cleaning fluid
- Always dry the parts carefully
- Clean the external optics at least every 30 days

## TECHNICAL SPECIFICATIONS

---

Refer to the product data sheet available for download on [www.vari-lite.com](http://www.vari-lite.com).

## AMERICAS

10911 Petal Street  
Dallas, TX 75235  
Tel: +1 214-647-7880  
Fax: +1 214-647-8039

## ASIA

Unit C, 14/F, Roxy Industry Centre  
41-49 Kwai Cheong Road  
Kwai Chung, Kwai Tsing  
Hong Kong  
Tel: +852 2796 9786  
Fax: +852 2798 6546

Room 1201, Freetown Tower D  
E 3rd Ring Rd S, 58  
Chaoyang Qu  
Beijing Shi, China  
Tel: +8610-58674776  
Fax: +8610-58674775

B-1-27, Dataran Cascades, No. 13A  
Jalan PJU 5/1  
Kota Damansara PJU 5  
47810 Petaling Jaya  
Selangor, Malaysia  
Tel: +60 3-7611 7302  
Fax: +60 3-7629 4192

## EUROPE

Rondweg Zuid 85  
Winterswijk 7102 JD  
Netherlands  
Tel: +31 543-542516  
Fax: +31 543-542513

24 Sovereign Park  
Coronation Road  
Park Royal, London  
NW10 7QP  
United Kingdom  
Tel: +44 020 8965 3209

## OCEANIA

14H Vega Place  
Rosedale  
Auckland 0632  
New Zealand  
Tel: +64 9-481-0100



© 2019 Signify Holding. All rights reserved.

All trademarks are owned by Signify Holding or their respective owners. The information provided herein is subject to change, without notice. Signify does not give any representation or warranty as to the accuracy or completeness of the information included herein and shall not be liable for any action in reliance thereon. The information presented in this document is not intended as any commercial offer and does not form part of any quotation or contract, unless otherwise agreed by Signify. Data subject to change.

VL800 EVENTWASH User Manual

Document no.: 912400575012UM

Version date: April 24 2020